

SPECTRE®

Performance

Intake Installation Instructions

P/N 9017 (red filter) - P/N 9017B (blue filter)

P/N 9017K (black filter)

Year/Make/Model/Engine

2008-2009 Pontiac G8 GT 6.0L V8

2008-2009 Pontiac G8 GXP 6.2L V8

2014 Chevrolet SS 6.2L V8

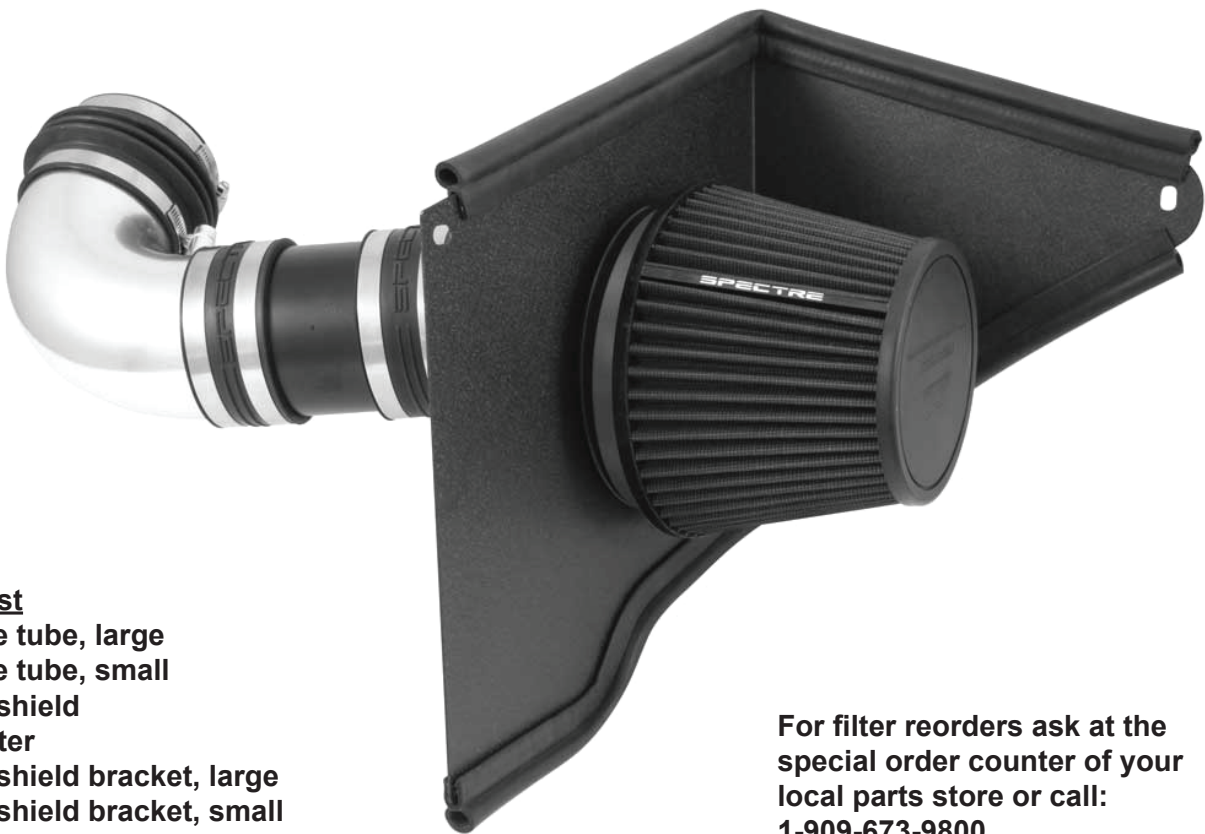

Parts List

- 1- Intake tube, large
- 1- Intake tube, small
- 1- Heat shield
- 1- Air filter
- 1- Heat shield bracket, large
- 1- Heat shield bracket, small
- 3- 4" Couplers
- 1- 4" Flex coupler
- 8- 4" Hose clamps
- 1- 6" Hose clamp
- 1- Thick MAFS spacer
- 2- Thin MAFS spacers
- 1- Offset funnel
- 1- Rubber seal
- 2- M6 Bolts
- 2- M6 Locknuts
- 2- M6 Washers
- 1- Zip tie
- 1- 3/8" ID Rubber Hose

Tools Required:

- 5/16" Nut Driver (or flat blade screwdriver)
- 10mm Deep socket
- 7mm Socket
- Ratchet
- Socket extension
- 10mm Wrench
- T-25 torx driver

For filter reorders ask at the special order counter of your local parts store or call:

1-909-673-9800

ask for: P/N HPR9886 (red filter)

P/N HPR9886B (blue filter)

P/N HPR9886K (black filter)

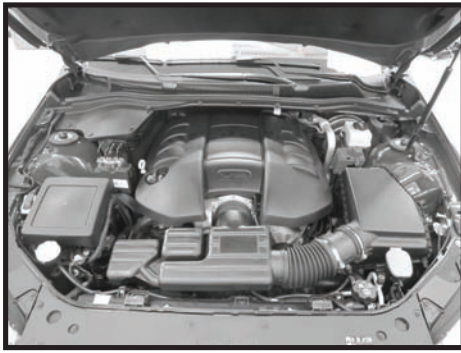

Step 1

Safety first! Before you begin the installation, make sure that the vehicle is in park (or neutral for a manual transmission) with the parking brake set. Disconnect the negative battery terminal and verify that all components that are listed are present. Note: This kit was designed and tested on a stock engine without any custom tuning done to the engine computer. Removing the battery cable may erase the programmed radio stations. The anti-theft code will need to be entered into some radios after the battery cable is connected. The anti-theft code can typically be found in the owner's manual or at your local dealership.



Step 2

Remove the oil cap to allow you to remove the plastic engine cover. Remove the engine top cover (if equipped) and reinstall the oil cap to ensure that nothing falls into the engine while you are working.

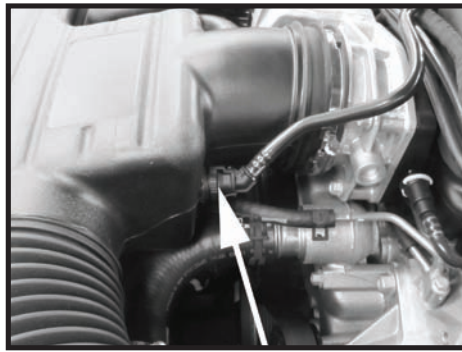

Step 3

Disconnect the breather hose that is positioned just to the right of the throttle body by squeezing the hose end and removing the hose from the air box.

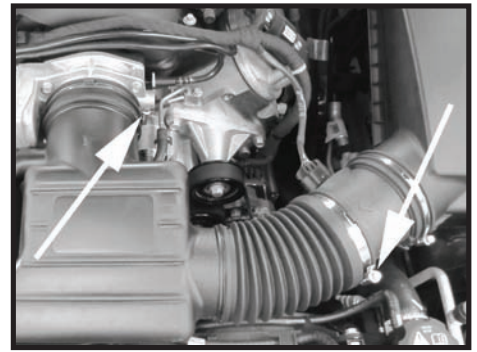

Step 4

Loosen the clamp at the throttle body and at the Mass Air Flow Sensor (MAFS). Remove the factory intake plenum from the vehicle.



Step 5

Remove the breather tube from the engine. There is a small tab on the end of the tube, push it to release the breather tube.

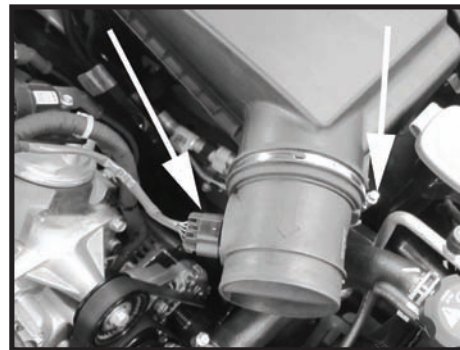

Step 6

Disconnect the MAFS electrical connector. Loosen the clamp for the MAFS from the air box and remove the MAFS from the vehicle. This will be reinstalled in a later step.

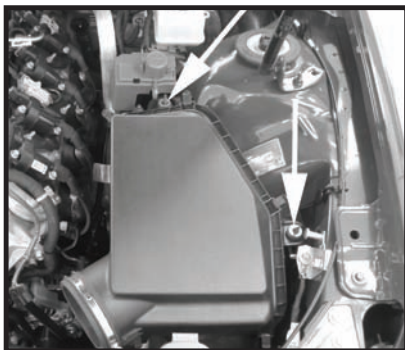

Step 7

Remove the two nuts that secure the factory air box in place. Once removed, lift the air box out of the vehicle including the factory scoop that is connected to the air box.

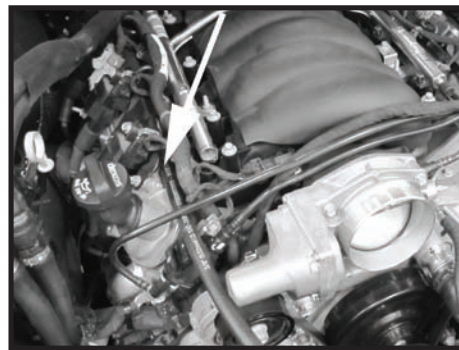

Step 8

Connect the supplied hose to the breather tube on the motor.

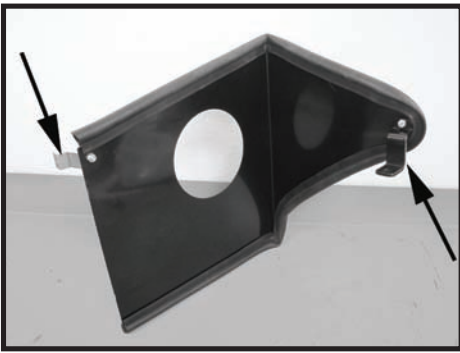

Step 9

Assemble the heat shield with the brackets fastened to the heat shield. The small heat shield bracket has the long end tab fastened to the outside face of the heat shield. The large heat shield bracket has the short end tab fastened to the inside of the heat shield. Install the rubber bulb seal.

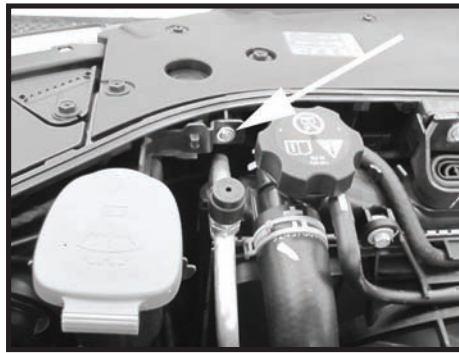

Step 10

Remove the mounting screw for the washer reservoir filler neck.



Step 11

Install the heat shield into place by sliding it into the area next to the radiator. Position the heat shield so the large bracket is over the stock stud in the rear and the small bracket is positioned over the hole for the washer filler neck. Install the nut on the large bracket that was removed in Step 7. Push down lightly on the heat shield to align the bracket and install the screw removed in Step 10.

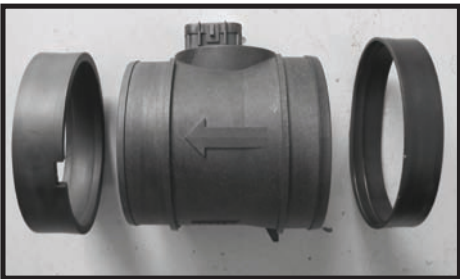

Step 12

Install the thick rubber spacer on end of the MAFS that the arrow is pointing too. Install the thin rubber spacer on the opposite end of the MAFS.

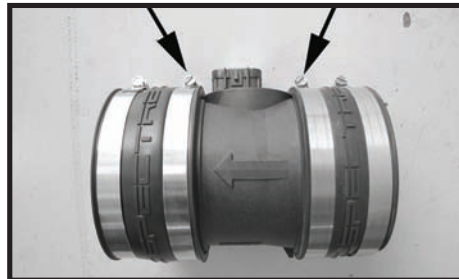

Step 13

Install the couplers on the end of the MAFS and fasten them securely in place. Install a second clamp on each coupler but do not tighten at this time.

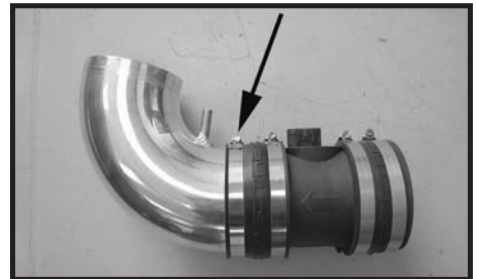

Step 14

Install the large intake tube with the MAFS pointing towards the intake tube.

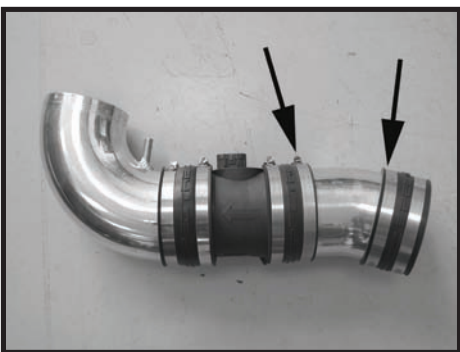

Step 15

Install the small intake tube with the longer end closer to the MAFS. Take note of the orientation of the tube, this may be rotated slightly once the assembly is installed in the vehicle.

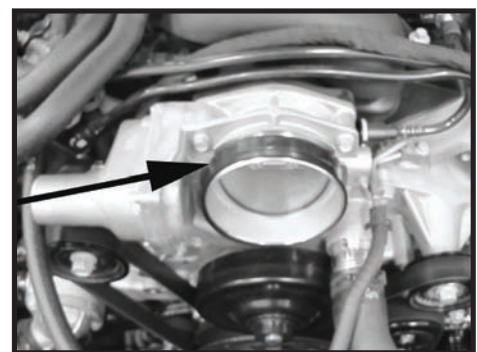

Step 16

Place the thin spacer on the throttle body.

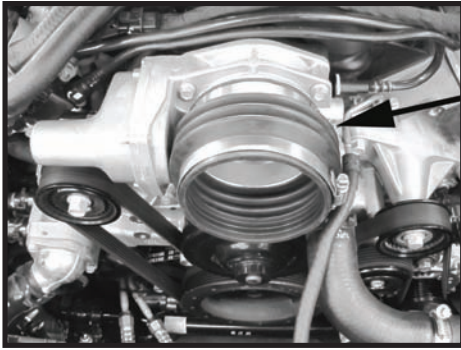

Step 17

Install the flex coupler on throttle body and clamp on the throttle body side to secure the boot in place. Install a second clamp but do not tighten at this time.

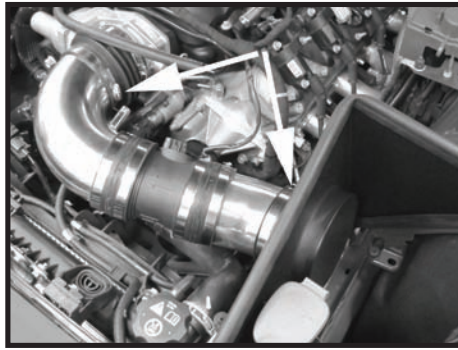

Step 18

Install the intake tube assembly. Place the velocity stack adapter in the heat shield and install this thru the coupler making sure the coupler is pushed completely against the heat shield. Take note of the orientation of the funnel, this may be rotated slightly once the filter is installed in the vehicle. Position the mass air flow sensor so that the connector is lower than the power steering hose if equipped. Position the intake tube assembly so that it is not touching the top radiator hose. Once the intake tube and funnel are lined up and in desired location, securely fasten everything in place.

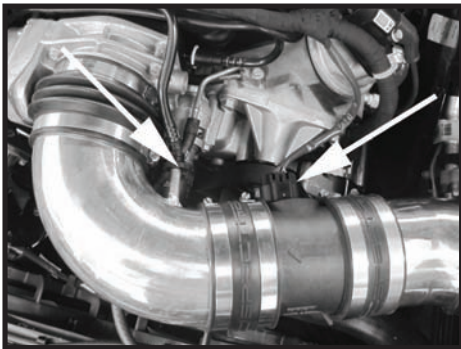

Step 19

Reconnect the MAFS wiring harness. Make sure the wire harness is not touching the power steering pulley or belt. If the MAFS wiring harness is close to the power steering pulley, use the supplied tie wrap to secure the wire to the power steering hose. Re connect the factory breather hose on to the intake tube.

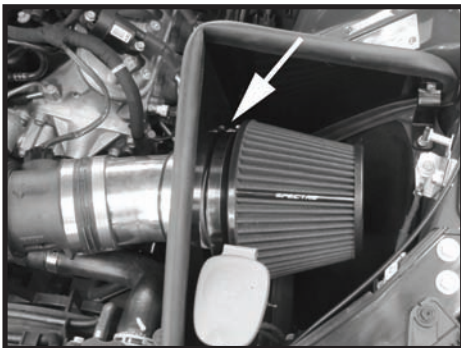

Step 20

Install the filter and fully tighten the clamp.

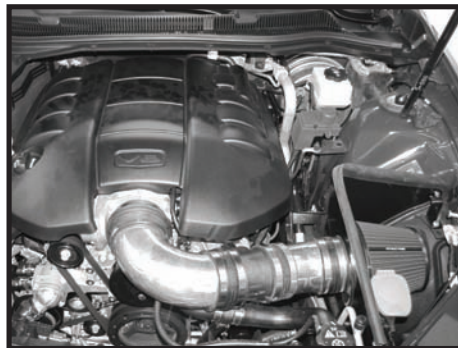

Step 21

Re install the engine cover. Make sure that all clamps and hardware are fully tightened. Reconnect the battery cable, start the vehicle and let it warm up. Shut off and inspect the installation once more for any loose clamps, wires, or hardware. Test drive & enjoy! Your installation is now complete. Periodically check all clamps and brackets.