

## PART NO. 25435

### Instruction Sheet

## TOYOTA REPLACEMENT CAMBER/CASTER CAM KIT

*This part should only be installed by personnel who have the necessary skill, training and tools to do the job correctly and safely. Incorrect installation can result in personal injury, vehicle damage and / or loss of vehicle control.*

1. Before beginning alignment, inspect for loose or worn parts and replace as necessary, check tire pressure, and look for odd tire wear.
2. Raise front of vehicle and properly support it by frame.
3. Install cams on bolts per **Figure 1**.
4. Install plastic sleeve on forward (larger) bolt.

**Note:** Cams may be stamped with all eight digits as indicated in **Figure 1**, or only with the last four digits of the indicated cam number.

5. One at a time, remove original cam assemblies from lower control arm and replace them with the SPC assembly, installing new assemblies as shown (**Figure 1**).

**SPC tool 40915 may help with removal of OEM cams. However, if tubes are solidly seized in bushings, you may not be able to remove them. To achieve camber/ caster change, you may need to replace upper control arms with SPC's Adjustable Upper Arms - check Sourcebook™ for correct applications.**

6. Install appropriate remaining cam and nut on each bolt and loosely tighten.
7. Lower vehicle, jounce suspension, and use cams to adjust alignment to desired settings by turning the bolt.

8. Hold head of bolt and tighten nut to 150 ft-lb to lock settings.

**Always check for proper clearance between suspension components and other components of the vehicle.**

9. Adjust toe and road test vehicle.

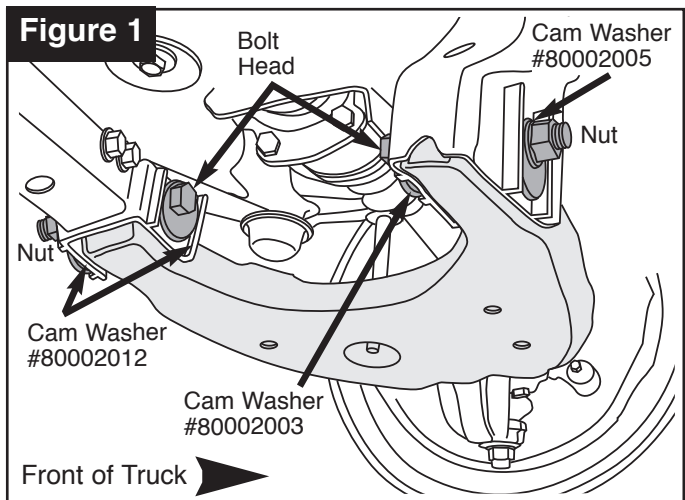

**Specialty Products Company®**