

RAV4 CAMBER/TOE CAM BOLT

This part should only be installed by personnel who have the necessary skill, training and tools to do the job correctly and safely. Incorrect installation can result in personal injury, vehicle damage and / or loss of vehicle control.

Plan Ahead - Read All Instructions BEFORE installing part.

Check for loose or worn parts, tire pressure, and odd tire wear patterns.

1. Raise vehicle and support by frame.
2. Preassemble SPC cam assemblies by placing one cam and one plastic sleeve on each bolt.
3. If installing for toe, remove forward lower control arm per manufacturer's procedure.

CAUTION: Spring is under load. Always use appropriate safety devices to support weight of vehicle while servicing any suspension component.

4. Reinstall lower forward control arm per manufacturer's procedure using an SPC cam assembly on inboard end of arm. Install second cam and loosely install nut.
5. If installing for camber, remove factory cam assembly from inboard end of rearward lower control arm and replace with SPC cam assembly. Install second cam and loosely install nut.

NOTE: Tightening fasteners with vehicle in raised position will cause bushing damage due to preloading bushing.

6. Lower vehicle.
7. Adjust toe or camber using SPC cam assemblies by turning bolts.
8. When finished adjusting, hold head of each bolt and tighten each nut to 115 lb-ft (156 N-m).
9. Complete alignment and road test vehicle.

Always check for proper clearance between suspension components and other components of the vehicle.

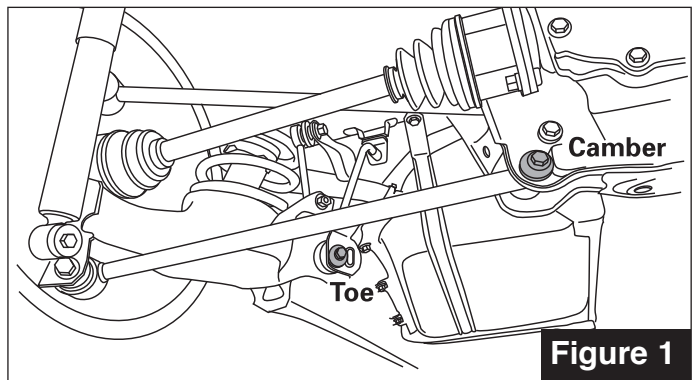

Figure 1



Specialty Products Company®