

Disclaimer: This installation guide is intended to clarify the install of your new Soul Performance Products exhaust. Please take proper precautions and safety measures when working on your vehicle and perform this work at your own risk

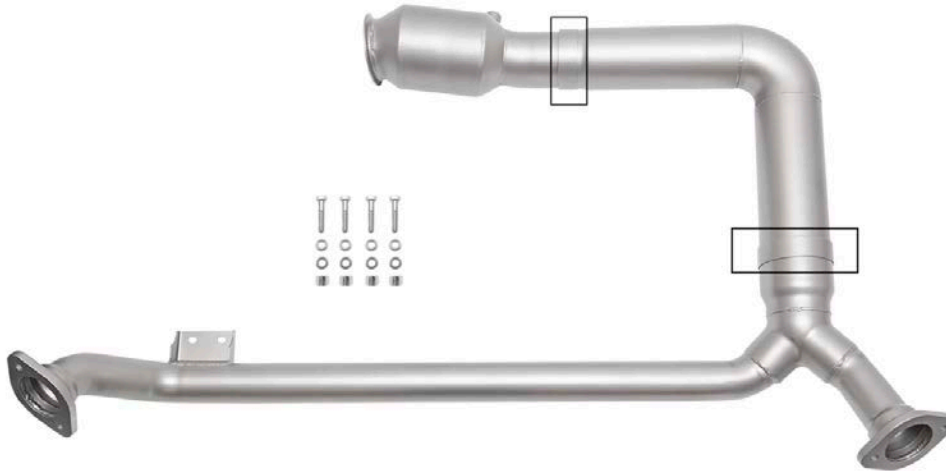

Please ensure that all components listed below are accounted for before beginning installation:

INCLUDED COMPONENTS

- (1) Cat Section
- (1) Mid Section
- (1) Y Section
- (4) M8-1.25X40MM Bolts
- (8) Washers
- (4) M8-1.25 Locking Nuts
- (1) Large Clamp
- (1) Small Clamp



Step 1: Loosen and remove the 13mm flange nuts on both overaxle pipes on the factory exhaust.



Step 2: Remove the PSE vacuum line if vehicle has the Porsche Sport Exhaust.



Step 3A: Locate the OEM band straps holding up the muffler on both the passenger and driver side.



Step 3B: Loosen both driver and passenger straps but do not yet remove the 6mm allen bolt on them.



Step 3C: Each bolt can now be swung free to release band straps - remove them.

Step 4: The muffler is now being supported on these hangers. Lift the muffler and begin to pull towards the rear.



Step 5: The OEM muffler can now be removed from the vehicle. We recommend two sets of hands or the use of a jack to support the weight of the muffler as it is quite heavy.



Step 6: Remove belly pan from the vehicle.

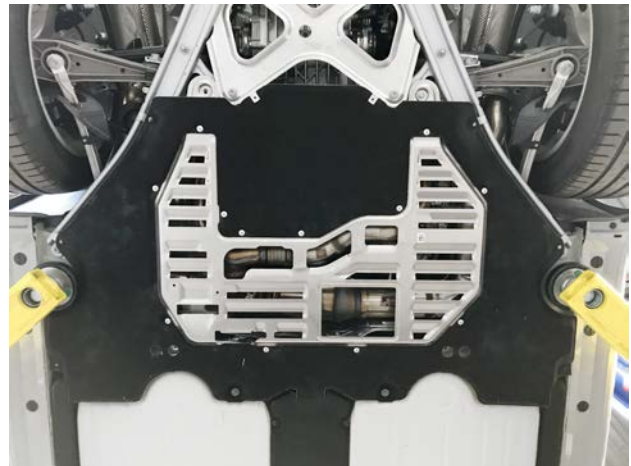

Step 7: Remove chassis braces to give better access to downpipe. (16mm nuts)





Step 8: Remove exhaust hanger (12mm nuts) from OEM Y pipe.

Step 9: Reinstall exhaust hanger on SOUL Y pipe. Snug the bolts but allow for slight movement for re installation.

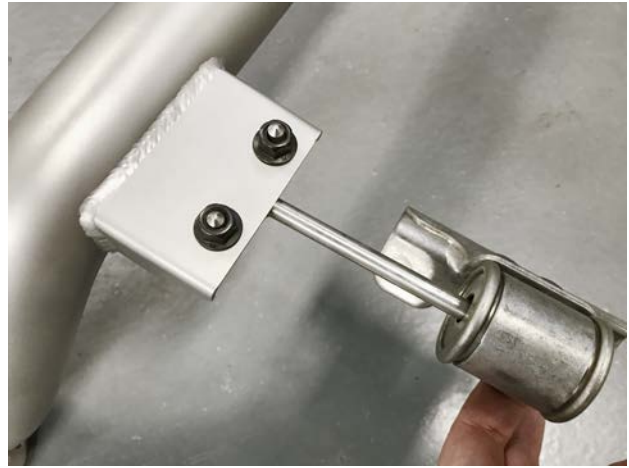

You can install the SOUL downpipe in one piece if you have extra hands, but we recommend installing the section that mates to the turbo and the 90 degree bend first THEN sliding the Y pipe in.



Step 10: Make sure the turbo and downpipe mating flanges are seated properly and install the OEM clamp on the cat section (with 90 degree bend section attached).

Step 11: Lift the new SOUL Y pipe section to the vehicle and start the exhaust hanger nuts to support the exhaust.



Step 12: Install exhaust bracket, torque to 15-18 Ft LBS.





Step 13: Reinstall O2 sensor.



Step 14: Tighten exhaust hanger nuts to 12-15 Ft LBS.



Step 15: Fully tighten OEM band strap onto the 90 degree downpipe section.

Step 16: Tighten both clamps holding downpipe sections together to 15-18 Ft LBS.



Step 17: Now that all downpipe clamps are in place and torqued down, replace and tighten chassis braces to 40-45 ftlbs .





Step 18: Reinstall belly pan and exhaust following the reverse procedure of installation.



Step 19: Use included hardware to mate downpipe to rear exhaust.

Correctly installed Sport Catalytic Converter downpipe.



You have now successfully completed the installation of your new Soul Performance Products exhaust components! Thank you for your business and if you have any questions during/after the installation please do not hesitate to call or email at the details below.

⚠ You may find that after your first full heat cycle of the exhaust that you need to re-adjust the tip placement to your liking. Additionally, the tone and sound of your exhaust will likely change as the mufflers get broken in, roughly a thousand miles or so.

⚠ You may notice smoke and fumes coming from the system upon first starting up the vehicle. This is due to oils used in manufacturing and is not a problem. The smell will dissipate in a short period of time after the exhaust has reached normal operating temperature.