

Super Hold Servo Kits

Part Nos.

K65703 Cover: Red Anodized

K65703-1 Cover: As shown

- Cover
- Piston
- Servo Pin
- Spacer
- Shim
- Spring
- E-clip
- O-Ring Seal, *Small* Not Shown
- O-Ring Seal, *Large*
- Lip Seals (2)
- Seal Rings (2)

Patent No. 6,907,974 & 7,047,611

Replacement Seal Kit

Part No.

65703-SK

- O-Ring Seal, *Small* Not Shown
- O-Ring Seal, *Large*
- Lip Seals (2)
- Seal Rings (2)

Replacement Servo Pin Kit

Part No.

65703-14K

- Servo Pin
- E-clip

GM 200, 200-4R, 200C

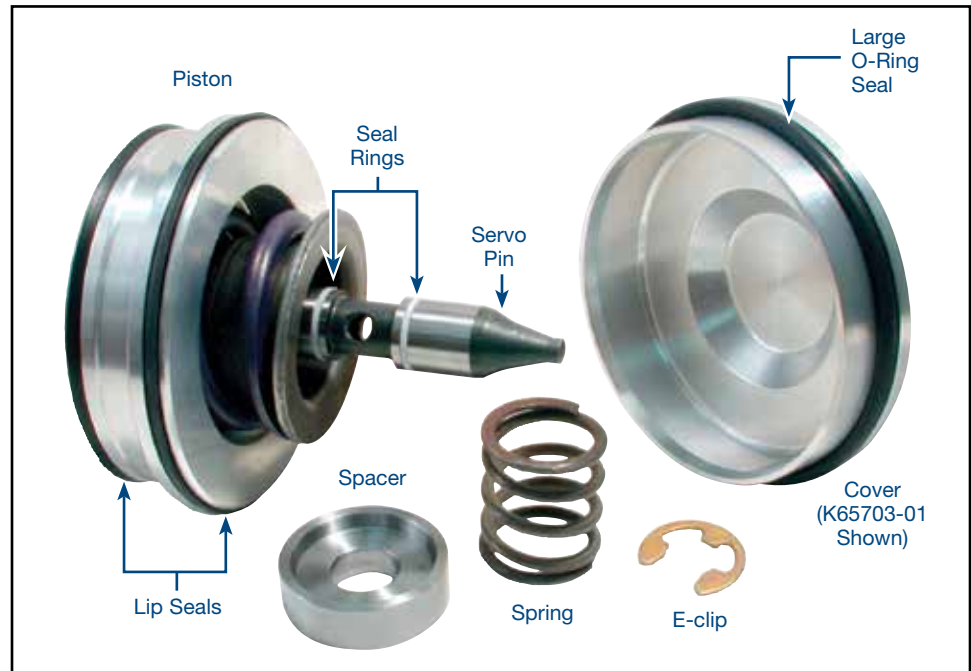

1. Set Servo Pin Travel

- Remove OE servo assembly. Discard everything except springs and bell-shaped spring retainer.
- Assemble Sonnax servo pin, spacer, piston, E-clip and cover (**Figure 1**).



NOTE: Do not install any Sonnax seals or the large spring at this time.

- Place small return spring on pin, then install assembly with cover and retaining ring into case.
- Check servo travel by pushing on cover. Grind tip of servo pin as necessary to achieve desired travel (about .110").



NOTE: It is important to maintain the spherical tip radius when grinding the pin. The inner hole of a 3/8" flat washer cut in half makes a good gauge for this (**Figure 2**).

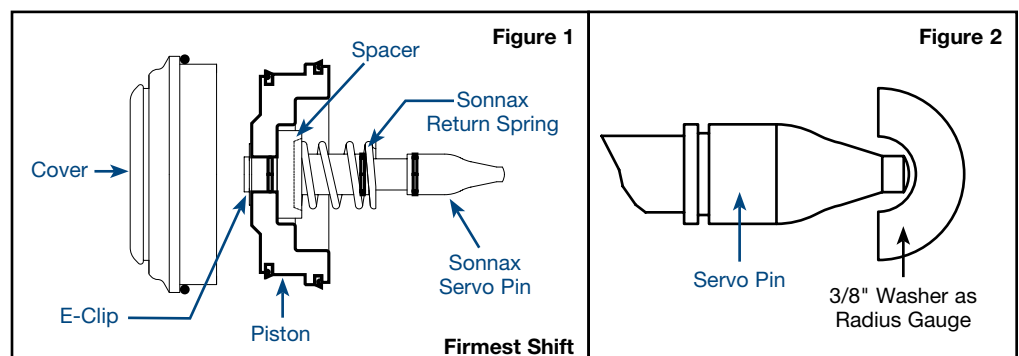

2. Select Servo Configuration

Recommended Set-up Procedure

Install components as shown (**Figure 3**) reusing OE cushion spring and the bell-shaped spring retainer. Install Sonnax return spring and shim. Do not use thick spacer.

For the Firmest Shift Set-up Procedure

For the firmest 1-2 and 2-3 shift, install the Sonnax solid spacer in place of the cushion spring with the bell shaped retainer (**Figure 1**).



CAUTION: Using the firmest shift setup can cause excessively hard shifts which lead to broken parts.

3. Install Servo

Install seals on pin, piston and cover. Lubricate with assembly gel and install servo assembly into case.

4. Air Test Servo

Leak test the 2nd apply and 3rd release sides of the servo with 1/4" O.D. tubing and a short piece of rubber vacuum line (**Figure 4**).

