

## GM 4L60, 200C, 200-4R & Ford AOD

### TV Cable Corrector Kit for Holley Carburetors

#### Part No.

### AS4-04K

- TV Corrector Plate
- Bolt
- Spring
- Nut
- Washer
- Retainer



**NOTE:** The Sonnax TV corrector plate in this kit works best when used with Sonnax throttle cable and TV cable bracket **AS6-01**. Spring and retainer are not required for the 4L60 and AOD installations. For applications requiring a 1/4" ball stud with longer thread shank, source part number 73745G01 from a small engine service center or online.

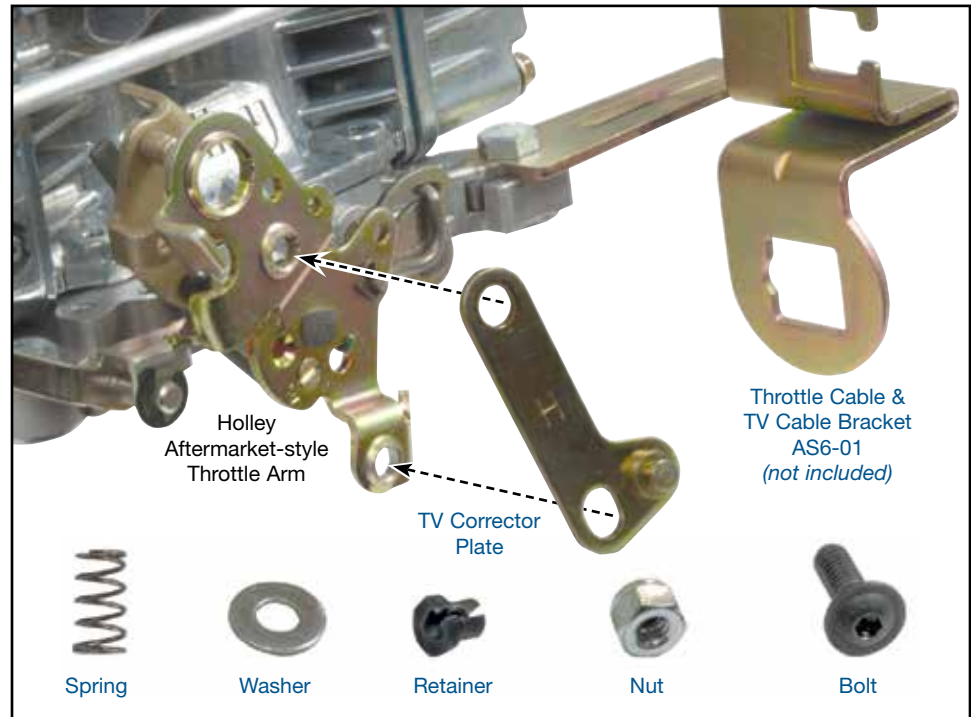

#### GM 4L60 & Ford AOD Installation Instructions



**WARNING:** This kit is only suited for carburetors with Holley aftermarket-style throttle arm as shown in main figure. This kit is not intended to work with throttle arms on OE Holley carburetors or other Holley full-face styles of throttle arm.

**NOTE:** See page 2 for GM 200C/200-4R instructions.

1. Install the Sonnax TV corrector plate onto the carburetor throttle arm (**Figure 1**). Align the TV and throttle stud holes of the TV corrector plate with the TV and throttle holes on the carburetor's throttle arm. Make sure the new TV stud faces away from the carburetor.
2. Reinstall the OE throttle stud. Do not tighten the stud yet.
3. Install the Sonnax bolt and nut through the TV stud holes of TV corrector plate and arm and tighten. Tighten the throttle stud.
4. Attach both the TV cable and throttle cable. Adjust using OEM cable adjustment procedures if possible, otherwise ensure that the cable is pulled all the way out (maximum TV) at wide-open throttle.

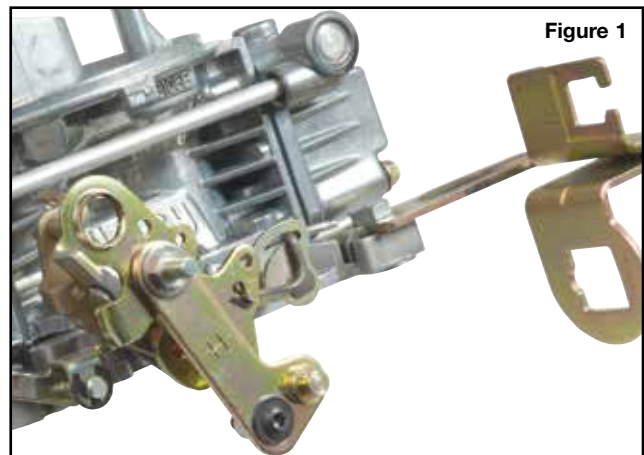

**Figure 1**

5. **Checks and Verification:** With the throttle in the idle position, mark the cable where it enters the cable housing. Rotate throttle arm and hold in the wide-open throttle position with the cable pulled out of the cable housing. Measure distance between mark on cable and cable housing. Distance should be 1.48" (1-31/64") for the GM 4L60 and Ford AOD (**Figures 2 & 3**, page 2).

### GM 200C & 200-4R Installation Instructions

**NOTE:** GM 200C and 200-4R applications can be set up with either the “quick” or “precise” installation methods.

#### Quick Installation Method

1. Install Sonnax TV corrector plate onto the carburetor throttle arm (**Figure 1**). Align the TV and throttle stud holes of the TV corrector plate with the TV and throttle holes on the carburetor's throttle arm. Make sure the new TV stud faces away from the carburetor.
2. Reinstall the OE throttle stud. Do not tighten the stud yet.
3. Install the Sonnax bolt and nut through the TV stud holes of TV corrector plate and arm and tighten. Tighten the throttle stud.
4. Slide TV cable plastic clip down cable exposing the cable stop near the end of the cable.
5. Slide Sonnax spring over the cable stop and onto the cable.
6. Slide the Sonnax retainer over the cable, between the cable stop and the new spring.
7. Slide spring over retainer and install OE TV cable plastic clip onto TV stud on TV corrector plate bracket. Correct installation should look like **Figure 4**.
8. Attach both the TV cable and throttle cable. Adjust using OEM cable adjustment procedures if possible, otherwise ensure that the cable is pulled all the out (maximum TV) at wide-open throttle.
9. **Checks and Verification:** With the throttle in the idle position, mark the cable where it enters the cable housing. Rotate throttle arm and hold in the wide-open throttle position with the cable pulled out of the cable housing. Measure distance between mark on cable and cable housing. Distance

should be 1.40" (1-13/32") for the GM 200C and 200-4R (**Figures 2 and 3**).

#### Precise Installation Method

1. Using a suitable file or grinding tool, elongate the upper hole on the Sonnax TV corrector plate to the indicated mark shown in (**Figure 5**).
2. Install the Sonnax TV corrector plate onto the carburetor throttle arm. Align the TV and throttle holes of the TV corrector plate with the TV and throttle holes on the carburetor's throttle arm. Make sure the new TV stud faces away from the carburetor.
3. Reinstall the OE throttle stud. Do not tighten the stud yet.
4. Install the Sonnax bolt and nut through the TV stud holes of TV corrector plate and arm. Push TV corrector plate upwards so that the fasteners are located at the bottom of the slotted holes in the TV corrector bracket. Tighten bolt and throttle stud while holding TV corrector plate in this position.
5. Attach both the TV cable and throttle cable. Adjust using OEM cable adjustment procedures if possible, otherwise ensure that the cable is pulled all the out (maximum TV) at wide-open throttle.
6. **Checks and Verification:** With the throttle in the idle position, mark the cable where it enters the cable housing. Rotate throttle arm and hold in the wide-open throttle position with the cable pulled out of the cable housing. Measure distance between mark on cable and cable housing. Distance should be 1.40" (1-13/32") for the GM 200 and 200-4R (**Figures 2 and 3**).

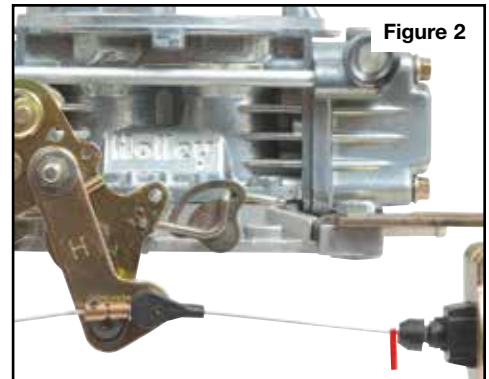

Figure 2

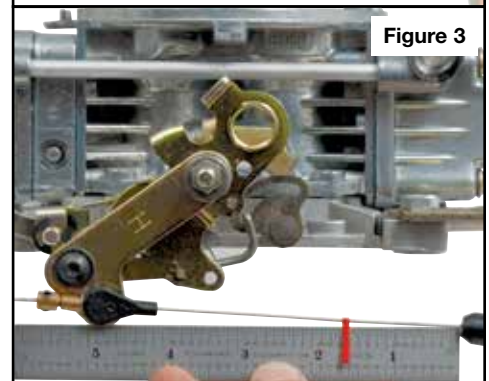

Figure 3

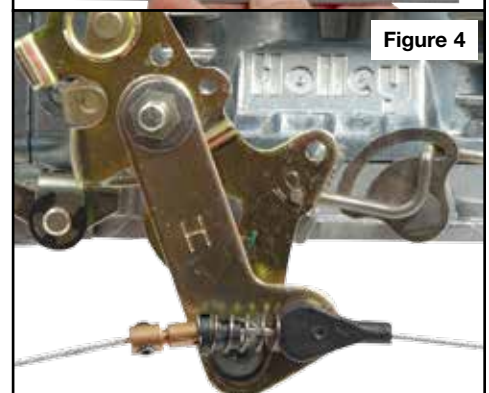

Figure 4

Elongate upper hole on the Sonnax TV corrector plate to this mark as shown here.

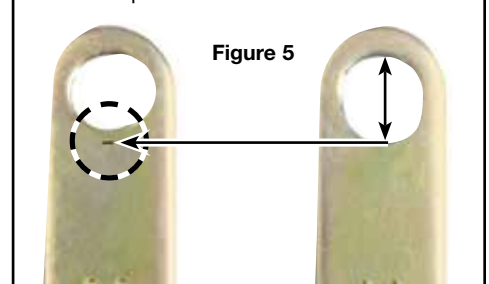

Figure 5