

2nd Gear Super Hold Servo Kit

Part No.

77911-03K

- 2nd Gear Piston
- Separator
- Apply Pin
- D-Rings, Small (2)
- D-Rings, Large (2)
- O-Ring, Small
- O-Rings, Large (2)
- PTFE Seals (2)

Also Available

Replacement Seal Kit

4th Gear Super Hold Dual Servo Kit

GM 4L60, 4L60-E, 4L65-E, 4L70-E

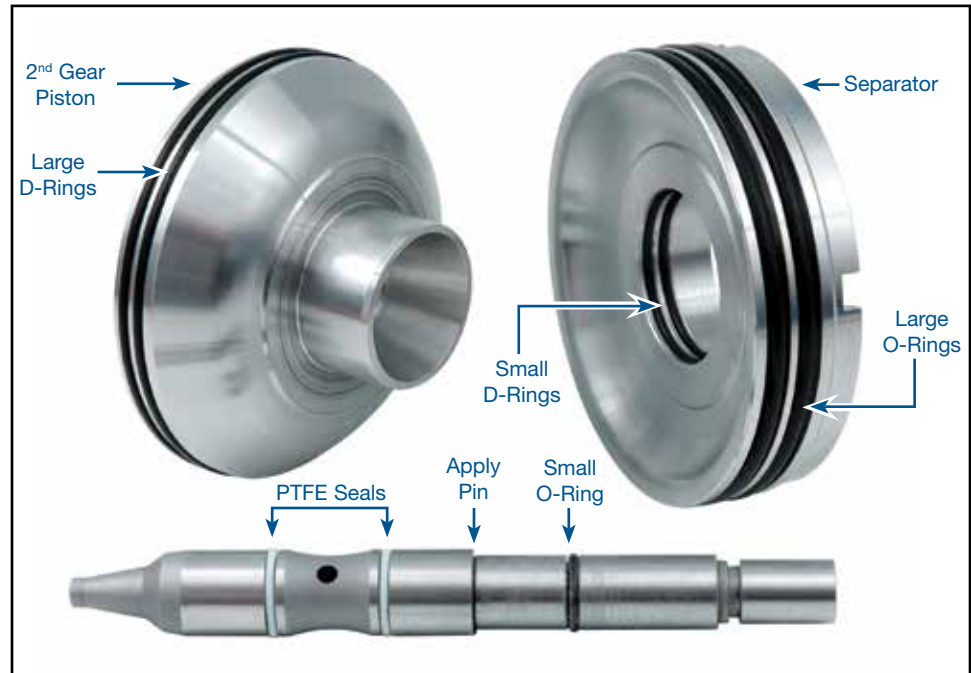

1. Installation Tips

- It is important to maintain a spherical tip radius when grinding the pin. The inner diameter of a 3/8" flat washer cut in half makes a good gauge for this (Figure 2, page 2).
- To prevent case damage, do NOT reuse servo-to-case retaining ring with the flat sides (MY 2004 up to mid-April 2004, see GM Bulletin 04-07-30-025A)
- If servo travel is insufficient, the band will not be able to fully release. Verify drum rotation by looking up into the case near the manual shaft while turning the output shaft. The drum should freely rotate inside the band.
- To cushion the 1-2 shift and reduce the 3-2 downshift clunk, install additional cushion spring (GM part #8681195).

2. Disassembly

Remove the OE servo assembly and disassemble 2nd gear servo piston, pin and cushion spring(s). Discard the OE pin, second piston and separator piston.

3. Servo Piston & Pin Assembly

Assemble the Sonnax 2nd gear servo, separator plate and remaining OE parts as shown in (Figure 1, page 2). Do not install any seals at this time. Ensure the 2nd gear release spring is on the pin.

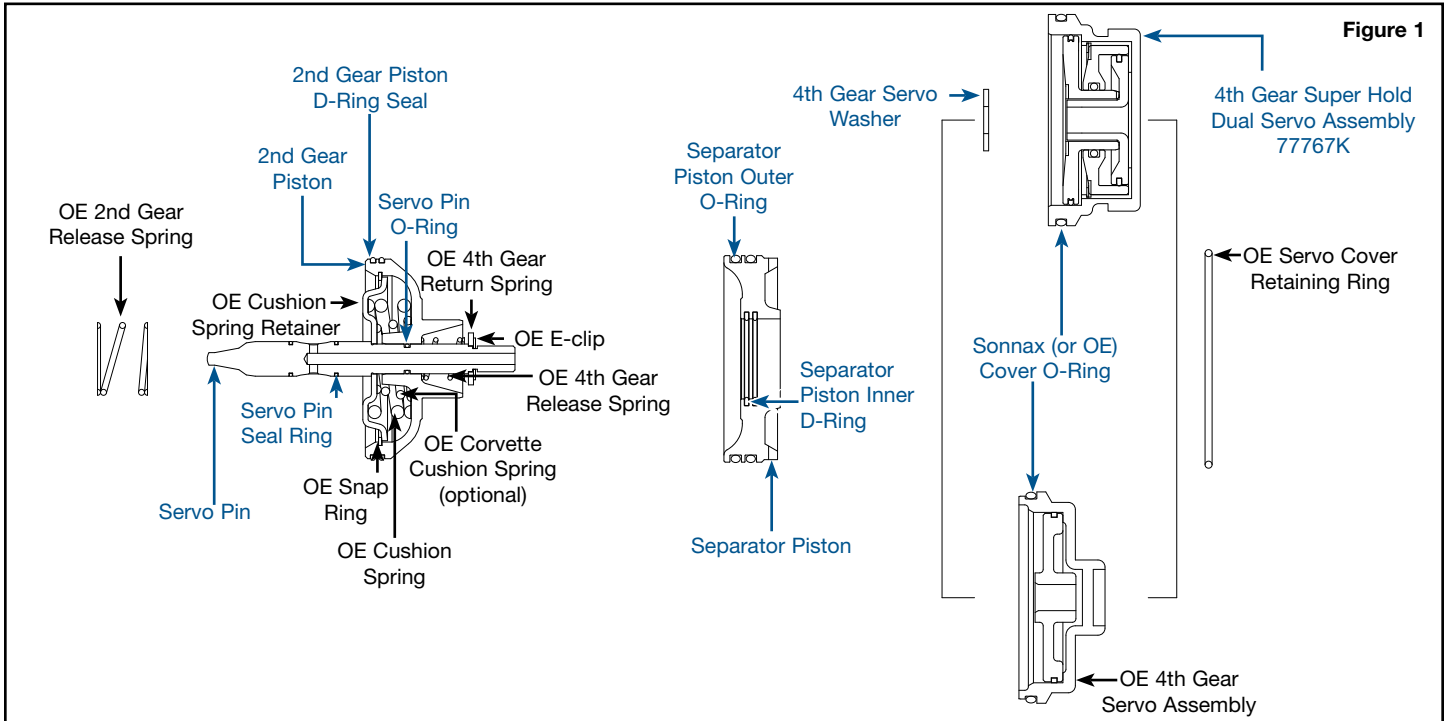

4. Set Pin Travel with Dial Indicator



NOTE: Sonnax servo pin is longer than the longest available OE pin. ON AVERAGE, around .100" of material must be removed from Sonnax pin to achieve desired travel (**Figure 2**).

- Install the 2nd gear servo assembly, 4th gear servo assembly and retaining ring into case.
- Set the dial indicator (**Figure 3**).
- Depress the servo cover and measure the distance the cover travels.
- Grind pin tip as necessary to achieve .075" to .125" of servo travel.

5. Final Assembly

- Remove servo assembly.
- Install the small O-ring onto Sonnax pin. Lubricate the O-ring with TransJel™. Insert the servo pin into the 2nd gear servo assembly, taking care not to shear the O-ring. Install the 4th gear release spring, spring retainer and E-clip.
- Install the two small PTFE seals onto the servo pin.
- Install the two large gear D-ring seals onto the 2nd gear servo piston.
- Install the two large O-rings on the outside of separator piston and install smaller D-ring seals into the inside of the separator piston.

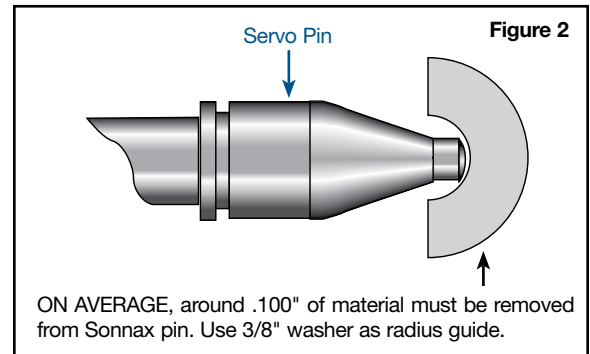

5. Final Assembly (continued)

- f. Lubricate the inner D-ring seals and install the separator piston onto the 2nd gear servo assembly.
- g. Place 2nd gear release spring in the servo bore. Lubricate outer D-ring and O-ring seals. Install the 2nd gear servo/separator piston assembly into the case.
- h. Install the servo cover O-ring onto the 4th servo assembly. Lubricate the cover O-ring.
- i. Install the 4th gear servo assembly into the case.
- j. Install the servo retaining ring (Installation Tips page 1).
- k. Verify retaining ring is fully seated in case.

6. Air Test Servo

- a. When air checking during overhaul (and pump removed), check for leaks of 3rd clutch oil at the OE 3rd accumulator checkball capsule (No. 2 in **Figure 4**).
- b. No. 1 in (**Figure 4**) is orifice to spray lube oil onto 2-4 band. Some leakage here is normal.



WARNING: If using Sonnax 4th gear super hold dual servo kit **77767K**, do not air test 4th apply unless band and drum are in place, otherwise 4th apply seals may come out of position.

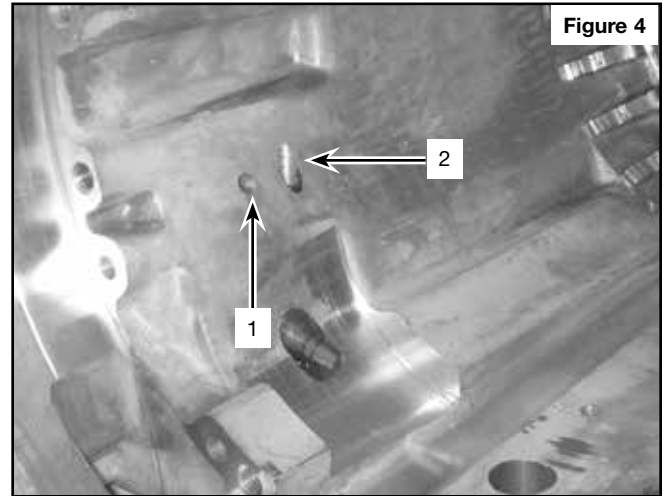

Figure 4

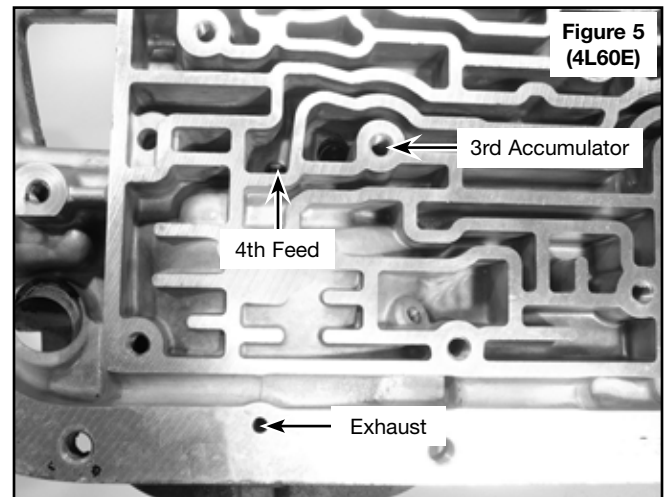

Figure 5
(4L60E)

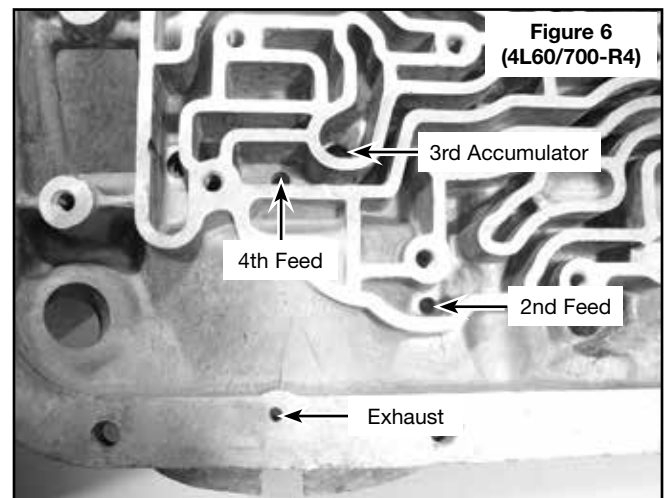

Figure 6
(4L60/700-R4)