

GM 4L60, 4L60-E, 4L65-E, 4L70-E

Input Drum Reinforcement Kit

Part No.

77733-51K

- Reinforcement Sleeve
- Overrun Piston Inner Seal
- Overrun Piston
- Overrun Piston Outer Seal

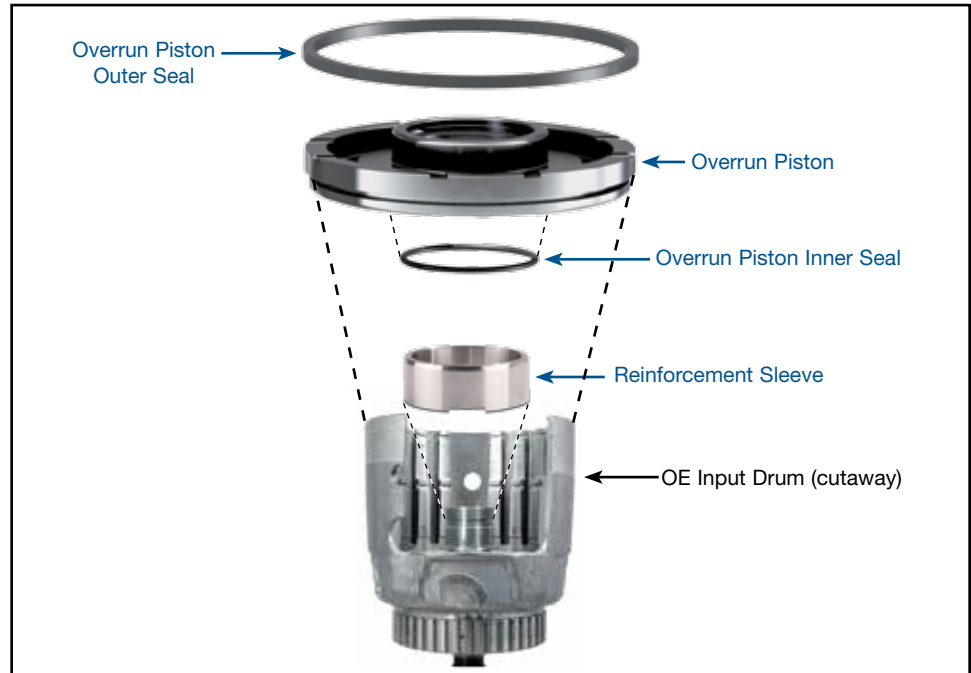

Use Stamped Steel Forward Piston

This kit must be used with a '97-later stamped steel forward piston (**Figure 1**). It cannot be used with '96-earlier aluminum forward piston or Sonnax billet forward piston 77764-01.

Use Dual-Cage Return Spring

This kit must be used with a '97-later dual-cage return spring (24206085), identified by stamped retainers on both ends of the springs (**Figure 2**). Although not required, the '96-earlier style return spring is about 10% stronger and preferred for high-RPM applications.

To use the early-style return spring, swap the bottom spring retainer from a '97-later spring onto the '96-earlier spring.

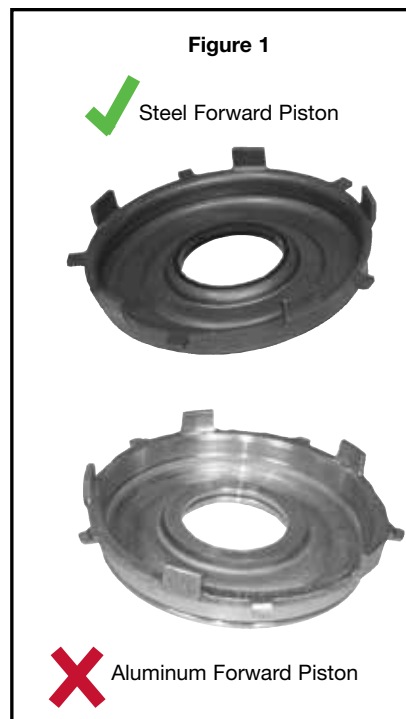

1. Sleeve Installation

- Set the input drum into a suitable press. Support the aluminum housing as indicated (**Figure 3**) using an appropriate sized tube or a spare (not to be reused) 4L60 stator shaft and selective spacer (with bearing left out).



CAUTION: Failure to support the drum as indicated can result in damage to the housing.

- Coat the inside of the sleeve with green Loctite® 609. Align the notch in the sleeve with the over run feed hole in the housing (**Figure 4**). Set the sleeve into position on the input drum, keeping the notch in the sleeve aligned with the over run feed hole in the housing.
- Using the press, install sleeve until just barely seated. Do not seat sleeve with the full force of the press since excessive pressure will ruin the housing. Do NOT hammer or pound the sleeve into place.
- Verify over run feed hole is not blocked by the sleeve.

2. Input Drum Assembly

Assemble input drum as usual.



CAUTION: See notes on page 1 regarding piston and return spring.

