

GM 4L60, 4L60-E, 4L65-E, 4L70-E

2.84 Ratio Input Carrier Kit

Part No.
77284-K

- Carrier Assembly
- Input Sun Gear

NOTE: Fits '06-earlier reaction shafts only. Requires use of OE bearing 8642191 or 24217327 (not included in kit).



Identify & Obtain Compatible Bearing

OE bearing 8642191 *or* 24217327 (.142" thick) MUST BE used with this kit (Figure 1).



NOTE: OE bearing 24236092 (.244" thick) CANNOT be used with this kit (Figure 1).



sonnax[®] PERFORMANCE

HIGH PERFORMANCE TRANSMISSION PARTS

2.84 RATIO INPUT CARRIER KIT 77284-K-IN

Instructions



NOTE: In addition to correct bearing, this kit requires use of '06-earlier reaction shaft (**Figure 2**). DO NOT use '07-later reaction shaft (**Figure 3**).

Only '06-earlier reaction shafts can be used with this kit. This shaft has an extra step on bearing riding surface "A" (**Figure 2**). Dimension "B" will be either 2.600" or 2.650" dia. Dimension "C" will be .100" deep.

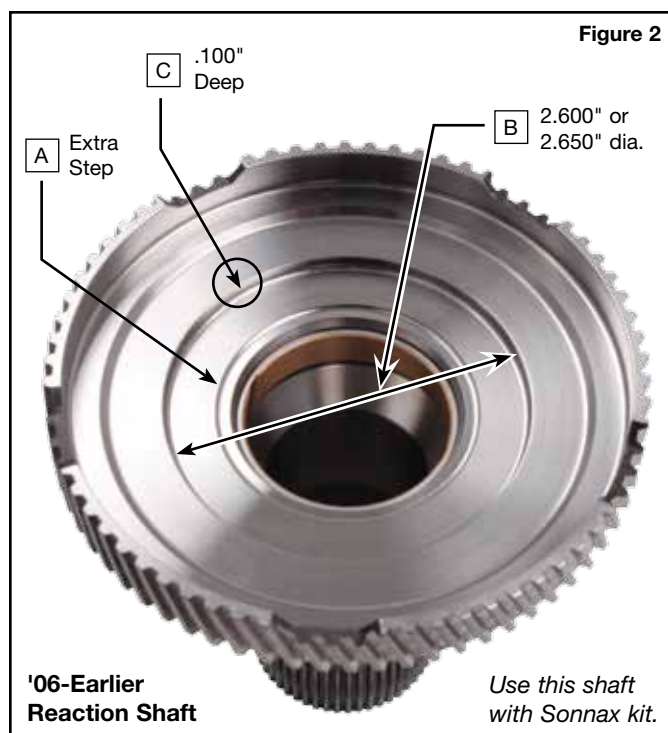

'07-Later reaction shafts CANNOT be used with this kit. This shaft does not have an extra step on bearing riding surface "A" (**Figure 3**). Dimension "B" will be 2.490" dia. Dimension "C" will be .130" deep.

