

Super Hold Servo Kit

Part No.
76890-17KP

- Conical Washers (4)
- D-Ring Piston Seal
- Spacer
- Return Spring
- Servo Pin
- E-Clip
- Servo Piston
- Servo Cover
- O-Rings (4)
- Washers (2)
- Gauge Tool

Also Available

Replacement Pin Kit
76890-15K

Replacement Seal Kit
76890-17SK

NOTES & CAUTIONS:

- Use caution when removing OE servo as components are under spring tension.
- Installation requires transmission pan and valve body removal. It is suggested to have a new set of valve body gaskets and a pan gasket before beginning.
- Servo travel and apply pin length must be checked and adjusted before use.
- When the servo is removed, the band end will move out of position. The servo cannot be reinstalled until the band is repositioned. **Figure 1** illustrates how to use a piece of coat hanger or similar stiff wire to keep the band pushed over toward the servo.

Ford AOD ('80-'93)



1. Remove OE Servo

- Remove transmission pan and valve body.
- Remove overdrive servo retaining ring and servo assembly from case. This is the large circular piston at the front of the case. Discard all pieces of the original servo except the case retaining ring.

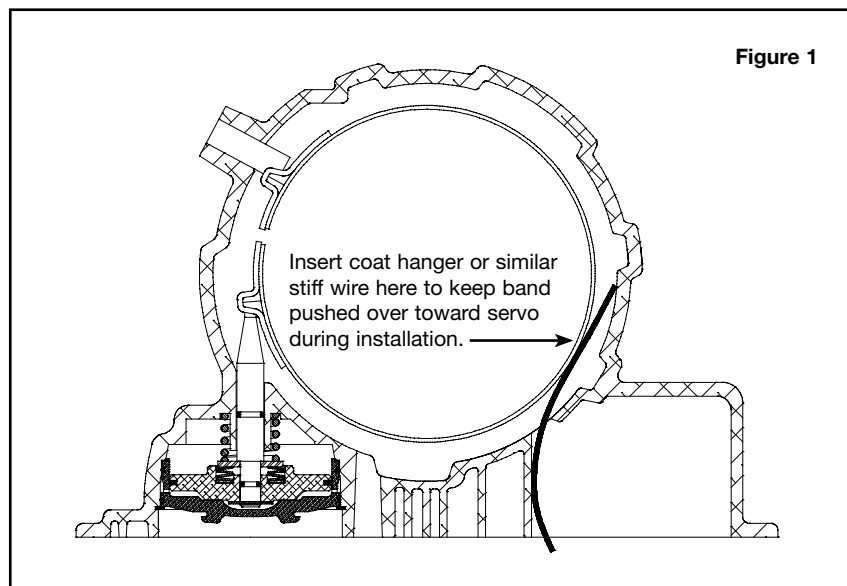

Figure 1

2. Check & Adjust Servo Travel

- Assemble the Sonnax servo with the spacer without any seals (Figure 2).
- Temporarily install the case retaining ring into the case.
- Insert servo assembly (without cover) into case. Push the servo until bottomed against the band.

NOTE: Ensure the pin properly engages the band by positioning the band (Figure 1).

- Use gauge tool included in the kit to measure between servo piston and retaining ring. Grind pin tip as necessary until gauge fits (Figure 2). When grinding pin tip, be sure to maintain radius (Figure 3).

3. Final Assembly

- Install seals onto servo pin, piston and cover. Lubricate seals and bore with TransJel™ or petroleum jelly.
- Assemble the servo piston/pin with the conical washers (Figure 4) or with the spacer (Figure 5).

NOTE: The recommended set up is with conical washers. The conical washers do not interfere with maximum holding power, but reduce excessive harshness and minimize 3-4 shift timing concerns which can occur when installing a larger overdrive servo. For firmer shifts, an optional setup is with the steel spacer installed in place of the conical washers.

- Place return spring over pin.
 - Insert piston into cover first, then install the servo assembly into the case.
- NOTE:** Ensure the pin properly engages the band by positioning the band (Figure 1).
- Carefully push servo assembly into case, compressing the return spring, and install the retaining ring.
 - Reinstall valve body. Tighten valve body bolts in a circular pattern in steps to a final torque of 80 to 100 in-lb.

