

2nd Gear Super Hold Servo Kit

Part No.

22301B-01K

- Cover
- Piston
- Sleeve
- Pin
- Retaining Ring
- Seals/Seal Rings (5)
- O-Rings (3)

Replacement Seal Kit

Part No.

22301B-SK

- Seals/Seal Rings (5)
- O-Rings (3)
- Retaining Ring

Chrysler 46RE, 46RH, 47RE, 47RH, 48RE, A727

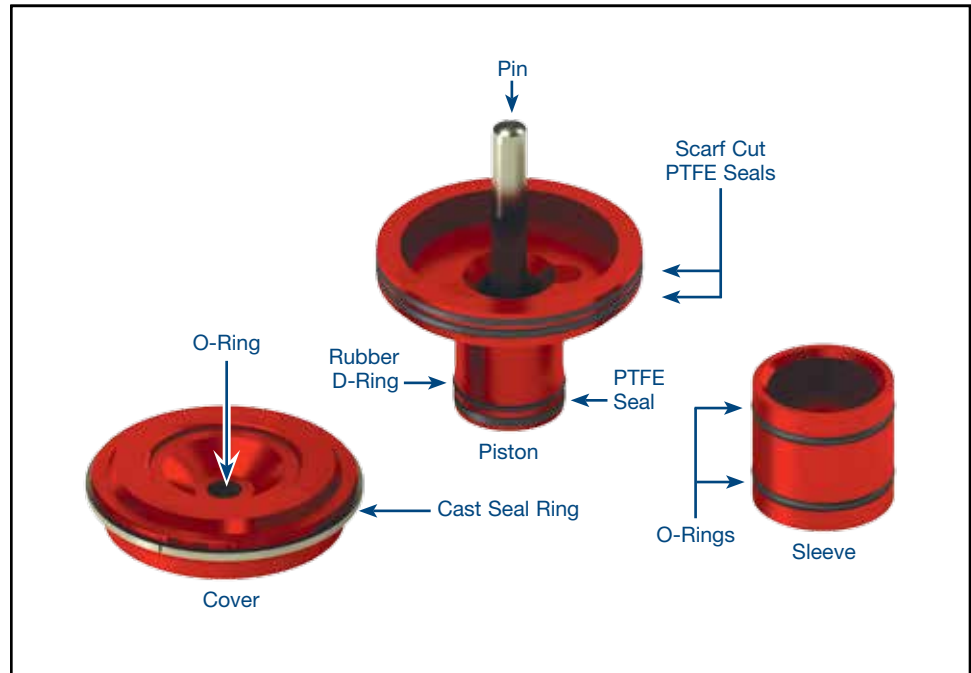

1. Assembly

- Insert the servo pin into the servo piston and pin in place with supplied retaining ring (Figure 1).
- Install the small PTFE seal and the small D-ring seal onto the small diameter of the apply piston as shown below. The PTFE seal goes in the outer seal groove; the D-ring goes in the inner seal groove.

Figure 1

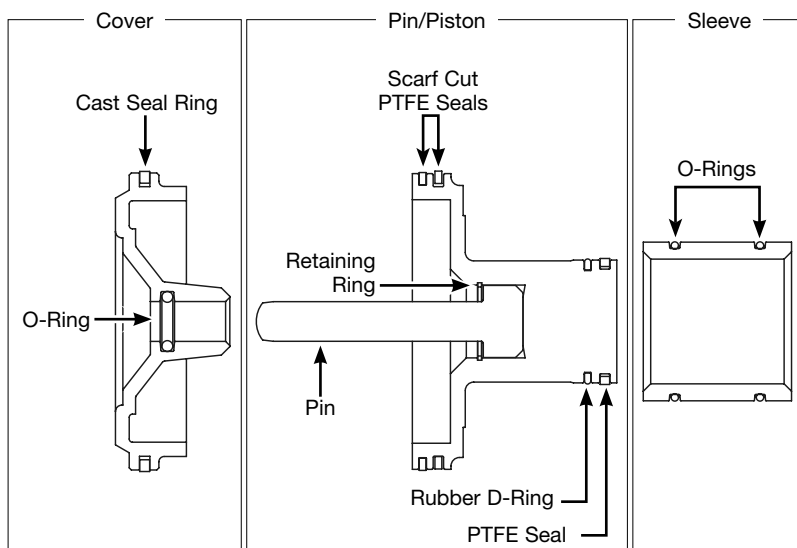

- Use the sleeve to size the PTFE seal by installing the sleeve over the PTFE and rubber seals on the piston.
- Install the two large rubber O-rings onto the sleeve.
- Install the two large, scarf cut PTFE seals onto the large diameter of the piston. It is normal for the two grooves to have different depths.



TECH TIP: Apply assembly lube to seat the seals.

- Install the large cast seal ring onto the cover.
- Install the small O-ring into the pin bore of the cover.
- Lube the O-ring in the cover, then temporarily install over the piston pin to confirm proper installation of the cover O-ring seal.

2. Installation

(with valve body and band strut removed)

- Remove the servo cover retaining ring and servo cover.
- Remove the servo piston assembly.
- Apply assembly lube to the sleeve O-rings, then install the sleeve into the servo bore, making sure it is bottomed out.
- Apply assembly lube to the piston seals, then insert the piston into the case and pre-installed sleeve.
- Install the large OE servo spring. If a smaller diameter spring is present on the servo pin, it should be discarded.
NOTE: In some A727 applications, the spring dimensions may not allow installation into the Sonnax servo. If this occurs, it will be necessary to source a spring from a later 46/47/48RHE unit.
- Place a mark on the outer face of the cover. Locate the ring end gap of the metal sealing ring so that it lines up with your mark.
- Insert the new cover and secure with retaining ring, making sure the retaining ring end gap is 180° from the mark on the cover and the sealing ring end gap.

3. Band Adjustment

Band adjustment specification depends largely on which lever is used. Factory specifications are as follows:

Tighten band adjustment screws to 72 in/lb and back off.	
Lever Ratio	Turns Out
2.5	2-7/8
3.8	1-7/8
5.0	1-1/2 to 1-3/4

An alternative method that works equally well regardless of which lever ratio is used is to measure the distance between the servo apply pin and the lever. Normal clearance is between .360" and .400" for all OE levers. A 3/8" (.375") spacer can be used as a gauge block for setting this clearance.



WARNING: The following modifications are **NOT** recommended:

- Use of aftermarket servo return spring
- Setting direct clutch clearances tighter than OE specification
- Eliminating waved direct pressure plate retaining ring
- Enlarging direct feed holes in separator plate (**Figure 2**)

These common aftermarket modifications negatively affect apply/release timing and may result in a bind-up.

