

**Thank you for purchasing your new SOLO WERKS S1 Coilover suspension.
IMPORTANT PLEASE READ BEFORE BEGINNING INSTALLATION:**

Please take a moment to review this installation process and verify that your kit is complete and all components have been received. If there are any questions during the process, contact us directly.

SOLO WERKS recommends that you have this kit installed by a qualified professional. Solo Werks or its authorized agents are not responsible for damage or failure resulting from an improper or modified installation. Do not use a pneumatic impact gun to torque the upper strut nut as damage may occur. All suspension related components must be inspected and in good working condition. You should inspect all bushings, tie rods, hubs, bearings, strut mounts, sway bar end links, wheels, tires, etc. and replace if necessary.

This suspension system was designed to work best with the factory wheel/tire combination. Any deviations from these specifications could result in significantly altered handling characteristics and/or increased interference risk to other vehicle components.

SOLO WERKS TIP: Depending on the offset & size your wheels/tires, wheel spacers may be required for proper fitment.

If suspension is lowered past the recommended measurements there can be possible interference with multiple vehicle components; (i.e. modification may be necessary to fender lips, seams etc.). This will also void your Solo Werks warranty.

After installing the suspension system, a four-wheel alignment must be performed according to manufacturer's specifications. Check and reset load- dependent brake compensator, ABS system and headlight aim according to manufacturer's specifications (If applicable).

ALL RUBBER- MOUNTED STRUT/ DAMPER ATTACH-MENTS MUST NOT BE FULLY TIGHTENED UNTIL AFTER THE SUSPENSION SYSTEM IS LOADED (WHEELS ON THE GROUND). OTHER MOUNTING FASTENERS (FOR EXAMPLE BRACKETS) MUST BE SECURELY TIGHTENED BEFORE LOAD IS PLACED ON THE SUSPENSION SYSTEM

Every effort has been made to avoid printing errors in our literature. However, if there are any application or specification errors or omissions we must disclaim responsibility.

Original Suspension Removal- Front:

1. Refer to OEM recommendations for proper jacking of vehicle
2. Support Lower Control Arm/Spindle with floor jack
3. Remove any hoses/lines from original suspension strut mounts
4. Locate top of strut in engine bay and remove cap from upper strut mount
5. Remove upper strut nut.
 - a. NOTE: It may be necessary to hold the damper shaft with allen wrench to keep from spinning.
6. Disconnect Sway bar endlink from lower control arm
7. Remove Lower retaining Bolts/Nuts from spindle (Caution: strut will now be free from vehicle)
 - a. Ensure that the lower control arm is still supported as to not stretch any brake hoses or lines
8. Remove strut assembly

NOTE: If you are using your existing upper strut mount and bearing (Fig 1 #4) you must remove these items from the strut assembly. These items are under extreme pressure from the front spring and must be removed using an appropriate spring compressor to relieve the pressure. Follow the directions given by the manufacturer of the Spring Compressor to safely remove the spring and disassemble the Strut Assembly.

SOLO WERKS TIP: *As the strut mounts and bearings are a consumable/wear item and are a known fail point on this chassis Solo Werks recommends replacing with new OEM mounts and new OEM Bearings and leaving your original suspension as an assembly. These parts are available from your Solo Werks Dealer or your local VW/Audi parts dealer.*

Solo Werks Coilover Pre-Assembly – Priming the Dampers

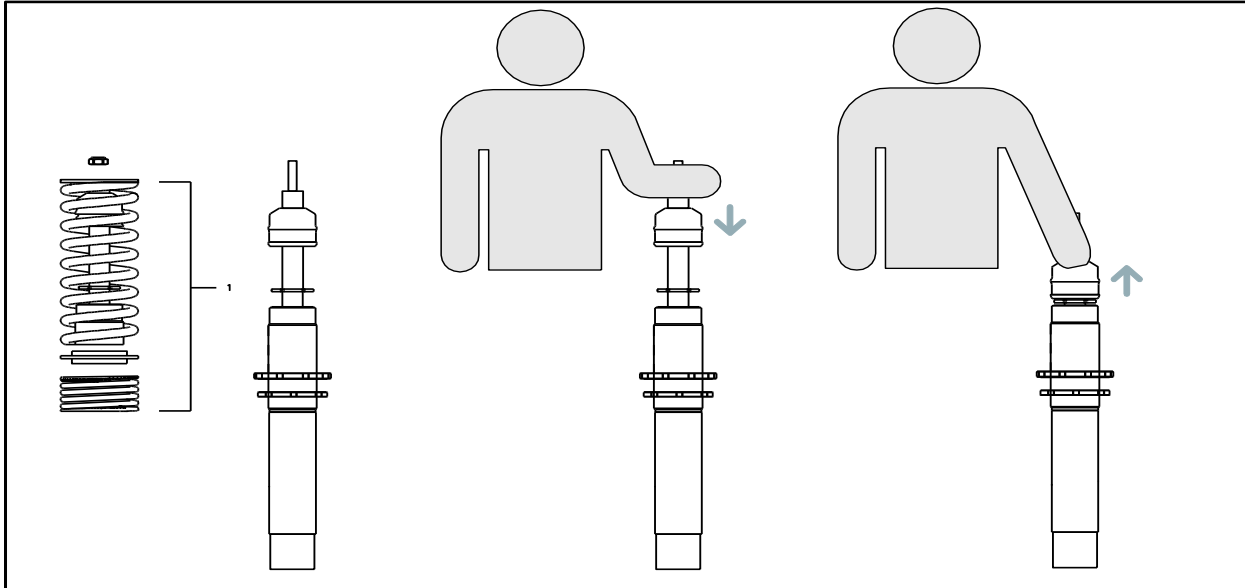

SOLO WERKS TIP: As the suspension is shipped and stored in a horizontal position, it is advisable to exercise or Prime the shock absorber before you install them to ensure that the internal contents are in the correct chambers. Therefore, we advise that before you assemble the front coilover shock absorber, take a moment to purge the shock absorber.

To do this, one side at a time remove the following from one of the front Coilover Assemblies (if equipped):

- Two Upper fasteners (lock nut and securing nut)
- Upper Spring Perch
- Main Spring
- Spring Isolator
- Helper Spring

You will then be left with the coilover strut with the bumpstop and vent disc on the shaft. Pull the bumpstop up to the top of the chrome shock shaft, just before the threaded portion.

With the shock upright (as it would be installed in the vehicle) compress the shock shaft until the bump stop touches the shock housing, and then pull to extend the shock shaft back to full extension.

Repeat 3-5 time minimums. You will notice the shock forces getting progressively harder each time. Once they feel consistent each way, you are ready to install.

Fig. 1 Front

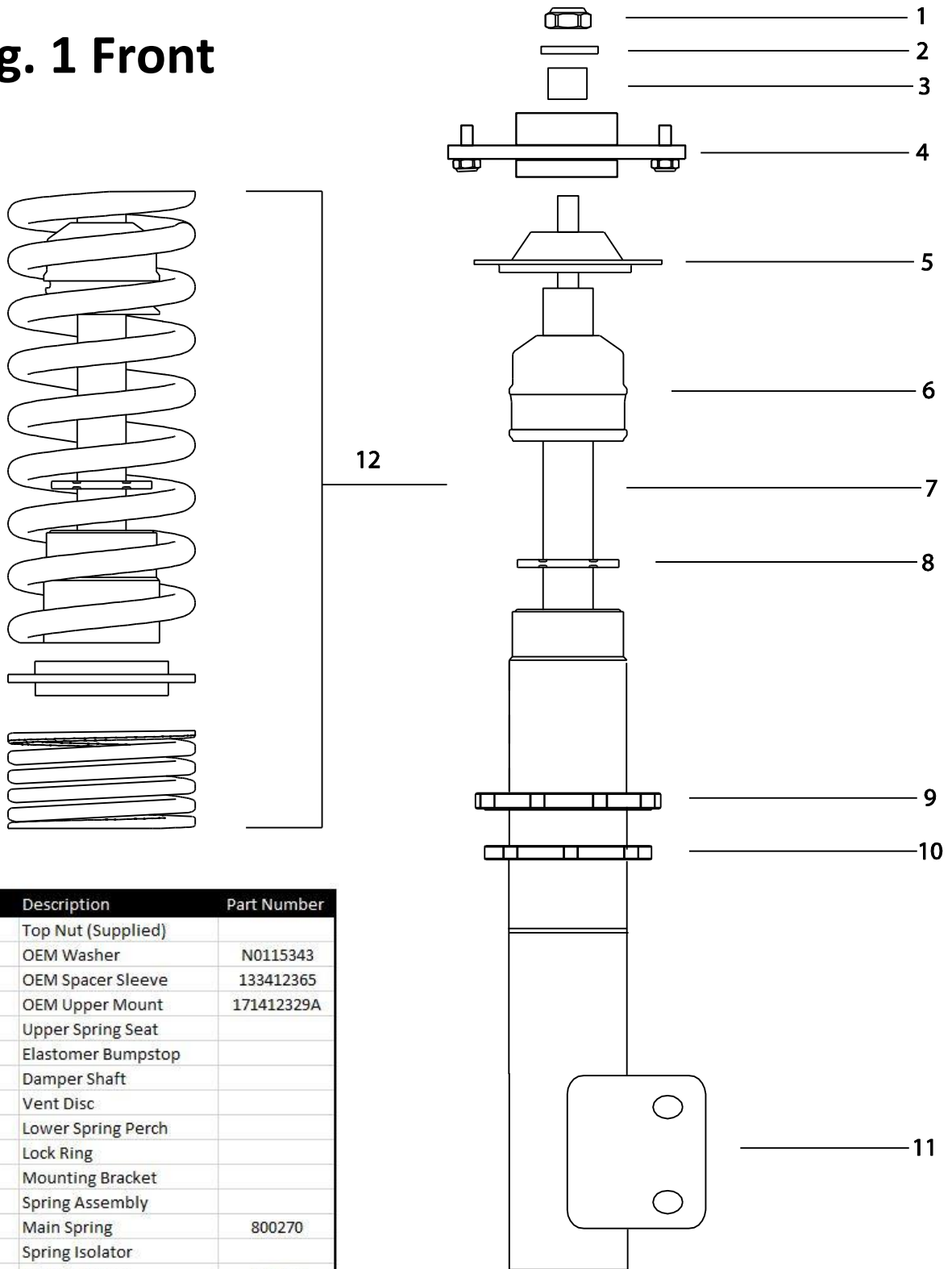

#	Description	Part Number
1	Top Nut (Supplied)	
2	OEM Washer	N0115343
3	OEM Spacer Sleeve	133412365
4	OEM Upper Mount	171412329A
5	Upper Spring Seat	
6	Elastomer Bumpstop	
7	Damper Shaft	
8	Vent Disc	
9	Lower Spring Perch	
10	Lock Ring	
11	Mounting Bracket	
12	Spring Assembly	
	Main Spring	800270
	Spring Isolator	
	Helper Spring	800030

Fig. 2 Rear

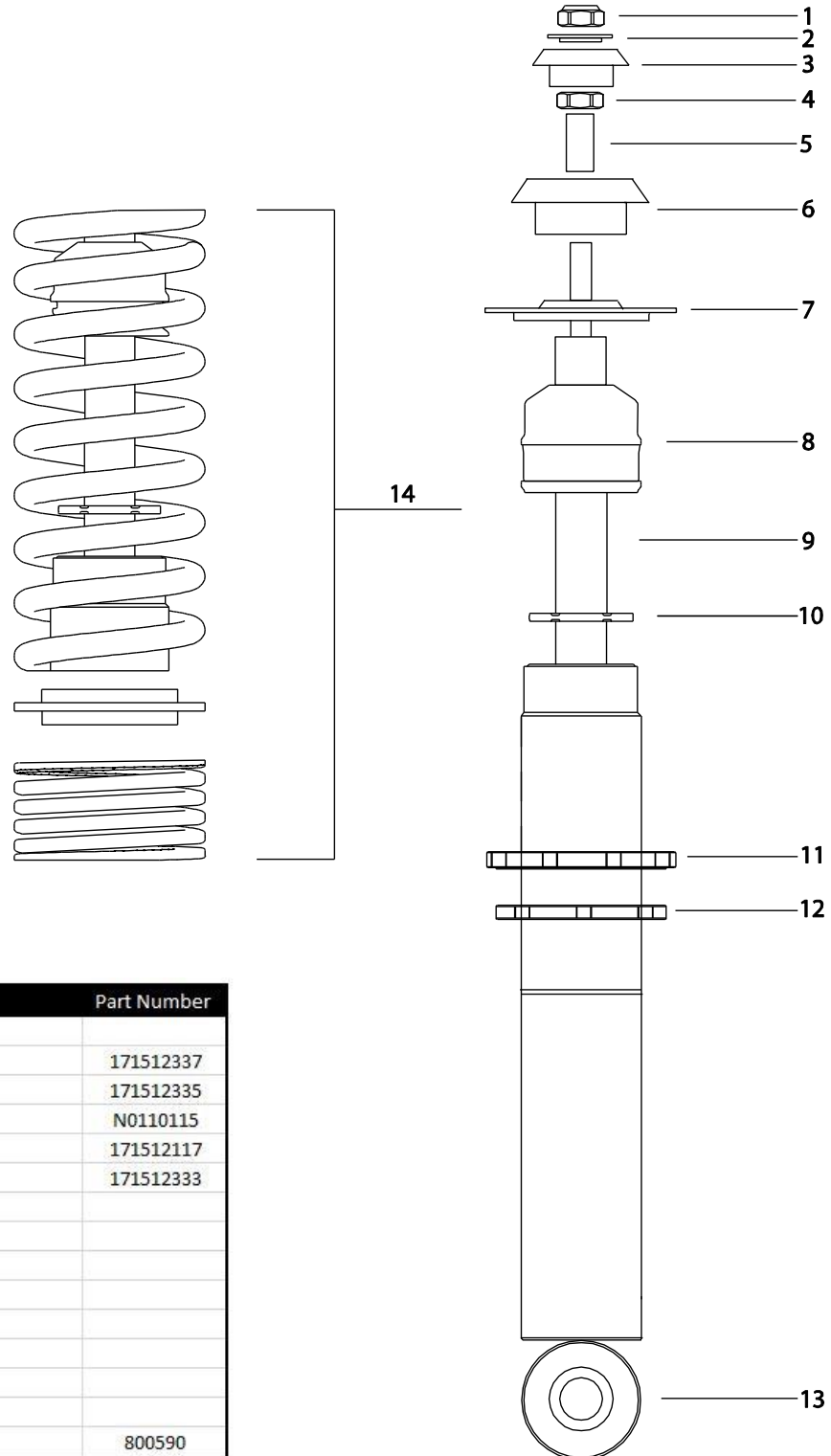

#	Description	Part Number
1	Top Nut (Supplied)	
2	OEM Washer (Disc)	171512337
3	Upper Bearing Ring	171512335
4	OEM Hex Nut	N0110115
5	OEM Spacer Sleeve	171512117
6	Lower Bearing Ring	171512333
7	Upper Spring Seat	
8	Elastomer Bumpstop	
9	Damper Shaft	
10	Vent Disc	
11	Lower Spring Perch	
12	Lock Ring	
13	Lower shock Mount	
14	Spring Assembly	
	Main Spring	800590
	Spring Isolator	
	Helper Spring	800030

Solo Werks Coilover Assembly and Installation – Front:

- 1. Work in the OEM Upper Bearings - Rotate the bearing a few times to break it in**
 - a. We have found that brand new or even existing bearings can get stuck as they have a very limited rotation when installed**
 - b. If they are stuck or too hard to move, they will not allow the assembly to rotate as it should and will create a spring bind that will produce a “boing” or “clang” sound of the springs recoiling**

Assemble the coilover assembly with the OEM Strut Mount and bearing using the provided hardware as in the diagram Fig.1

- a. Top nut should be torqued to 44 ft.-lbs. (Fig. 1 #4)
- b. Once assembled, we recommend starting the main perch at 25mm (1”) of thread remaining below the main perch/spring seat using the included spanner wrench – actual vehicle height will be set later in the process. (Fig.1 # 9&10)

NOTE: Use of an anti-corrosion spray such as the Boeshield T-9 on the threads & main perch/spring seat at this point (Fig.1 # 9&10) can make the adjustment process much easier and will add an extra layer of protection. Boeshield T-9 is available from your Solo Werks dealer.

2. Insert strut assembly into vehicle
 - a. Reinstall upper strut mount nuts (Hand tight) but do not torque at this time. (Fig.1 #1)
3. Replace lower spindle bolts through spindle housing (Fig.1 #11)
 - a. Insert strut assembly into Spindle housing and torque camber adjustment bolts to proper spec.
 - i. 19mm nut = 59 ft.-lbs.
 - ii. 18mm nut = 70 ft.-lbs.
4. Reattach sway bar endlinks
5. Repeat procedure on the other side.
6. Once vehicle is placed back on the ground under its own weight, Torque upper strut mount nut to 44 ft.-lbs.

Original Suspension Removal- Rear:

SOLO WORKS TIP: *It is necessary to access the upper rear strut mount via the trunk. Some trim panels may need to be removed to accomplish this.*

1. While Supporting lower control arm in the compressed position (loaded as if it is on the ground)
2. Remove the strut top cap from upper strut mount and undo the upper securing nut.
 - a. You can now remove the oem disc washer and upper bearing ring.
3. Remove the lower strut mount bolt and lower the control down and out of the way
 - a. Caution: OEM strut will now be free from vehicle
4. Remove OEM strut from vehicle
5. Using a properly rated strut compressor you can now remove the lower bearing ring to complete the disassembly. (Fig.2 #4,5,6)

Solo Werks Coilover Assembly and Installation – Rear:

SOLO WORKS TIP: *Just like the front struts, it is advisable to Prime the rear shocks as well. To purge the rear shocks: Refer to procedure on page 3.*

In the vertical position (as it would be installed in the vehicle):

1. Extend the shock rod to its full extent
2. Compress until 1" of the chrome shock rod is visible outside of the shock housing
3. Repeat 3-5 times or until the strokes feel consistent.

Solo Werks Coilover Assembly and Installation – Rear cont.

1. Before installation of Solo-Werks coilover take care to clean any mounting surfaces so they are free of any dirt or debris.
2. Assemble coilover per diagram (Fig. 2 Rear) (DO NOT INSTALL Fig.2 #(1,2&3) AT THIS TIME)
 - a. Strut top cover nut = 11 ft.-lbs.
 - b. Strut spacer retaining nut = 11 ft.-lbs.
3. Place top of strut into chassis and install OEM disc washer and upper bearing ring. (fig.2 # 2&3)
4. Tighten and torque second retaining nut. Fig.2 #1
 - a. Replace rear strut top cap
5. Replace lower strut mount bolt but do not tighten until all weight is on vehicle.
 - a. Torque lower strut mount bolt to 52 ft.-lbs.
6. Make final inspection, inspect all hardware is tight and torqued to proper values.
7. Adjust ride height.

Solo Werks Coilover Final Details – Heights & Working Ranges

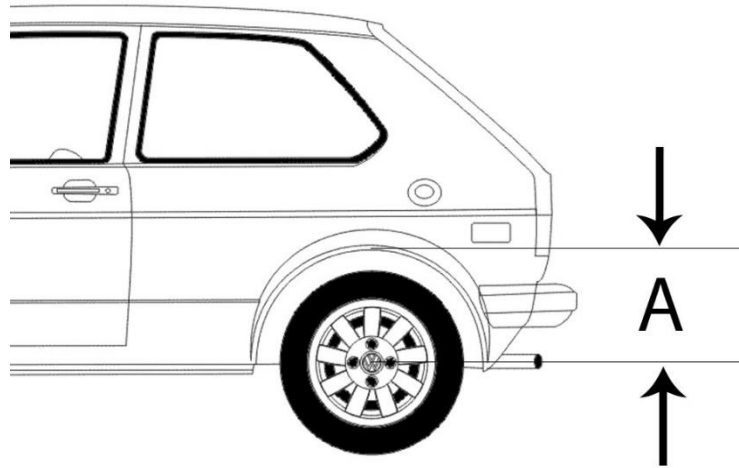

		Lowering Range			
		in mm		in inches	
Model	Year	Front	Rear	Front	Rear
Rabbit/Golf/Jetta		11 1/4"	315	12 3/8"	360
Scirocco I + II		11 1/4"	315	12 3/8"	360
Caddy Pickup		11 1/4"	315	12 3/8"	360
Cabriolet		11 1/4"	315	12 3/8"	360

Front Measurement						
Date	Max low mm	Max low Inch	Max high mm	Max high Inch	OEM mm	OEM Inch
Solo Spec	285	11 1/4"	315	12 3/8"	360	14 1/8"
Rear Measurement						
Date	Max low mm	Max low Inch	Max high mm	Max high Inch	OEM mm	OEM Inch
Solo Spec	285	11 1/4"	315	12 3/8"	360	14 1/8"

- These measurements are in place to allow both front and rear dampers to operate properly and allow for ample shock travel.
- All measurements will be referenced from “center of wheel hub to bottom lip of fender” (see example figure “a”)
- Using this system outside of this range can cause premature failure and is cause to void your manufacturer specified warranty.
- Helper springs are intended to keep preload on the main spring under full suspension extension, do not remove!

My Setup - Heights & Working Ranges

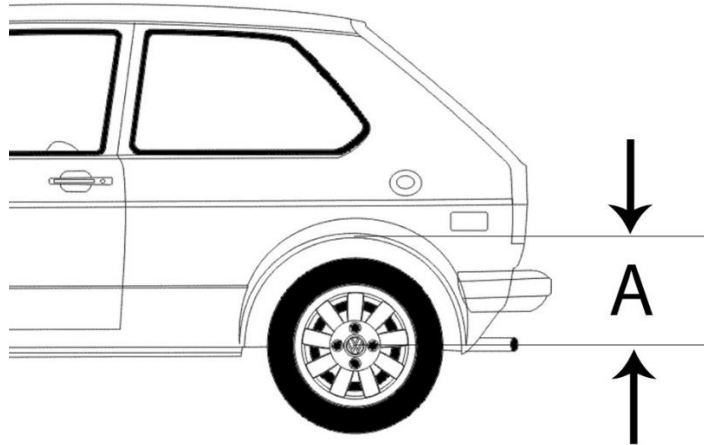

Use this page to record your setup heights for easy future reference

Front Measurement						
Date	Max low mm	Max low Inch	Max high mm	Max high Inch	OEM mm	OEM Inch
Solo Spec	285	11 1/4"	315	12 3/8"	360	14 1/8"

Rear Measurement						
Date	Max low mm	Max low Inch	Max high mm	Max high Inch	OEM mm	OEM Inch
Solo Spec	285	11 1/4"	315	12 3/8"	360	14 1/8"