

**Thank you for purchasing your new SOLO WERKS S1 Coilover suspension.**

**IMPORTANT PLEASE READ BEFORE BEGINNING INSTALLATION:**

Please take a moment to review this installation process and verify that your kit is complete and all components have been received. If there are any questions during the process, contact us directly.

SOLO WERKS recommends that you have this kit installed by a qualified professional. Solo Werks or its authorized agents are not responsible for damage or failure resulting from an improper or modified installation. Do not use a pneumatic impact gun to torque the upper strut nut as damage may occur.

All suspension related components must be inspected and in good working condition. You should inspect all bushings, tie rods, hubs, bearings, strut mounts, sway bar end links, wheels, tires, etc. and replace if necessary.

This suspension system was designed to work best with the factory wheel/tire combination. Any deviations from these specifications could result in significantly altered handling characteristics and/or increased interference risk to other vehicle components.

**SOLO WERKS TIP: Depending on the offset & size your wheels/tires, wheel spacers may be required for proper fitment.**

If suspension is lowered past the recommended measurements there can be possible interference with multiple vehicle components; (i.e. modification may be necessary to fender lips, seams etc...). This will also void your Solo Werks warranty.

After installing the suspension system, a four wheel alignment must be performed according to manufacturer's specifications. Check and reset load- dependent brake compensator, ABS system and headlight aim according to manufacturer's specifications (If applicable).

ALL RUBBER- MOUNTED STRUT/ DAMPER ATTACH-MENTS MUST NOT BE FULLY TIGHTENED UNTIL AFTER THE SUSPENSION SYSTEM IS LOADED (WHEELS ON THE GROUND). OTHER MOUNTING FASTENERS (FOR EXAMPLE BRACKETS) MUST BE SECURELY TIGHTENED BEFORE LOAD IS PLACED ON THE SUSPENSION SYSTEM

Every effort has been made to avoid printing errors in our literature. However if there are any application or specification errors or omissions we must disclaim responsibility.

**Fig. 1**

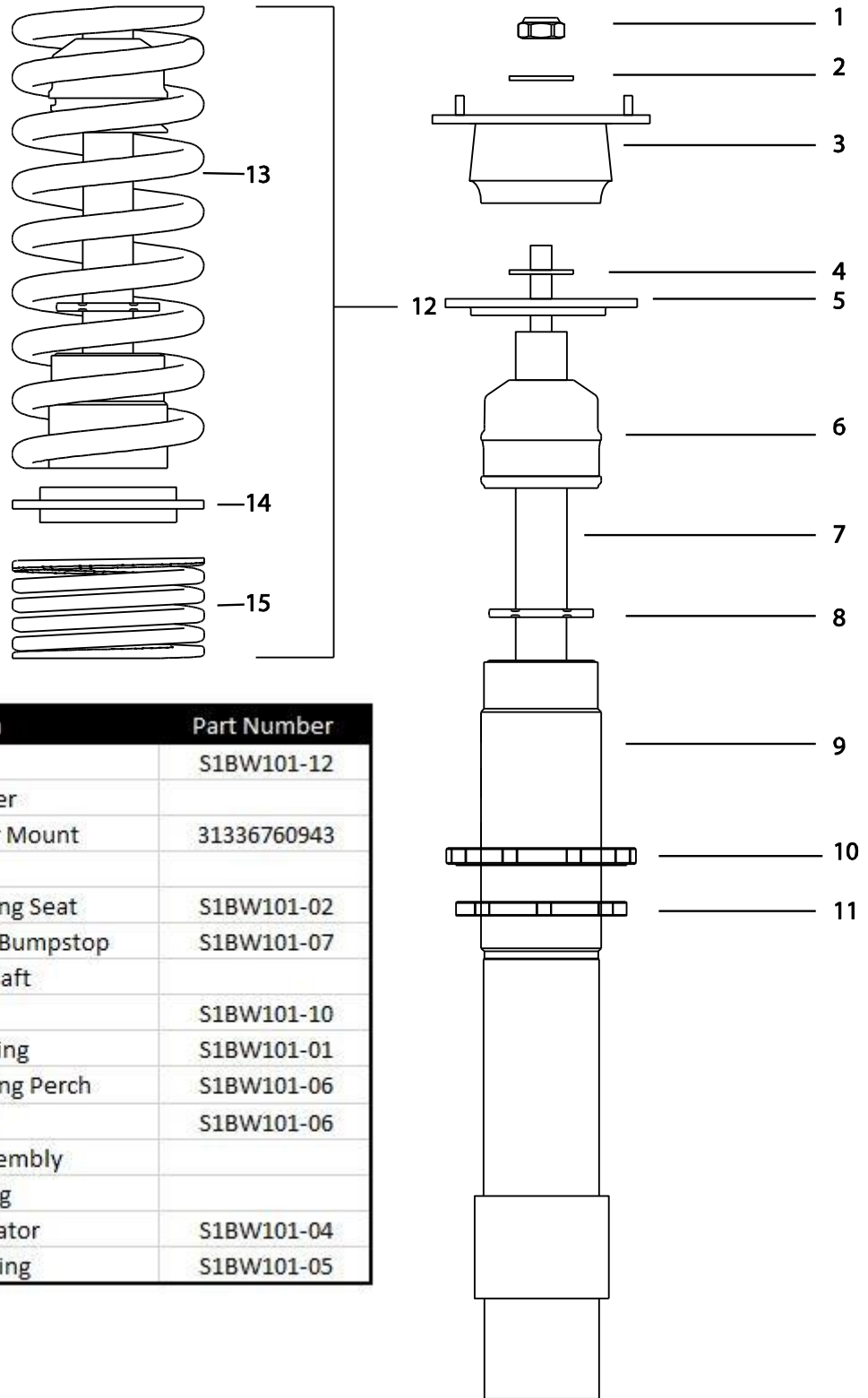

#	Description	Part Number
1	Top Nut	S1BW101-12
2	OEM Washer	
3	OEM Upper Mount	31336760943
4	Washer	
5	Upper Spring Seat	S1BW101-02
6	Elastomer Bumpstop	S1BW101-07
7	Damper Shaft	
8	Vent Disc	S1BW101-10
9	Strut Housing	S1BW101-01
10	Lower Spring Perch	S1BW101-06
11	Lock Ring	S1BW101-06
12	Spring Assembly	
13	Main Spring	
14	Spring Isolator	S1BW101-04
15	Helper Spring	S1BW101-05

**Fig. 2**

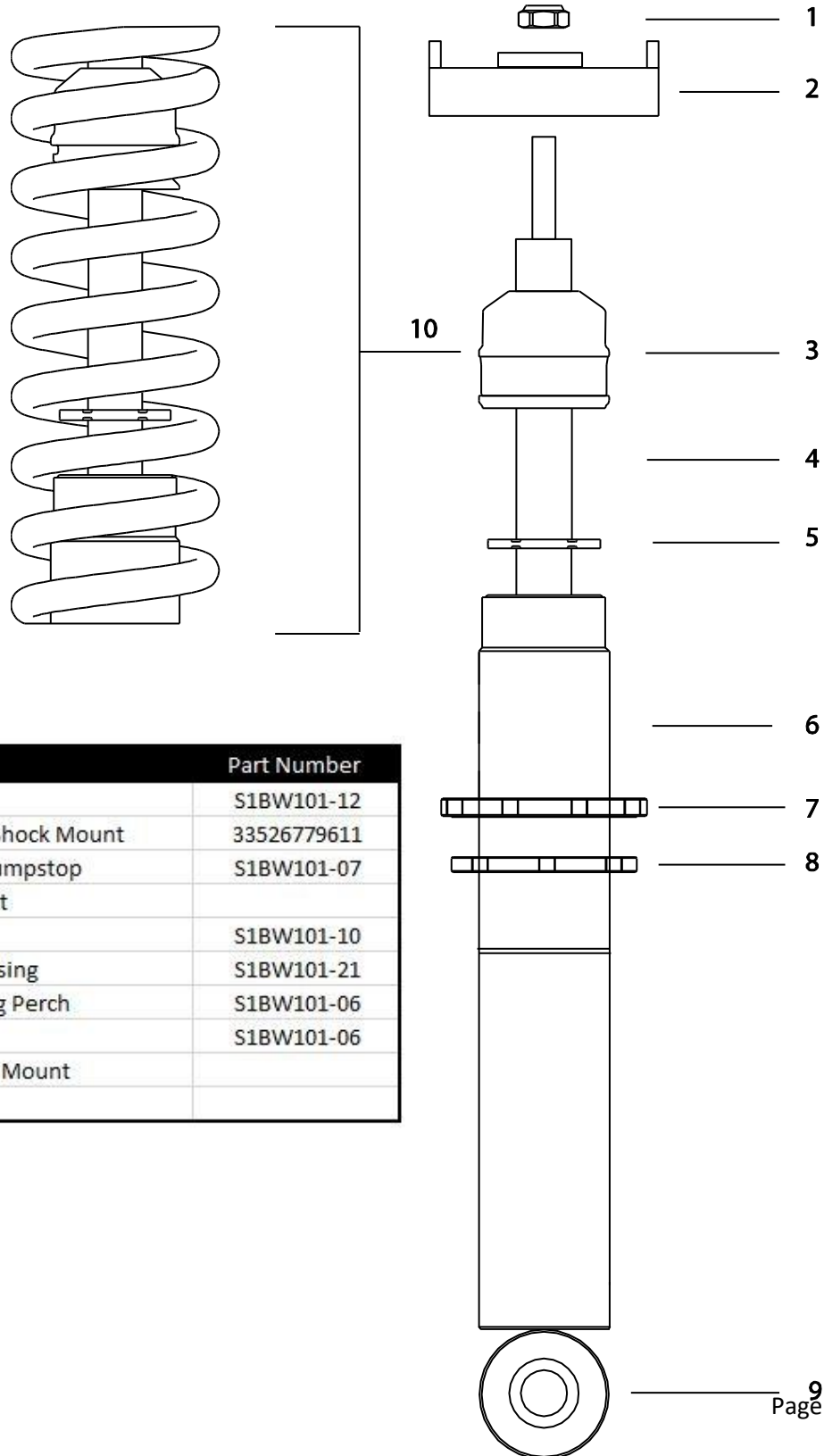

#	Description	Part Number
1	Top Nut	S1BW101-12
2	OEM Upper Shock Mount	33526779611
3	Elastomer Bumpstop	S1BW101-07
4	Damper Shaft	
5	Vent Disc	S1BW101-10
6	Damper Housing	S1BW101-21
7	Lower Spring Perch	S1BW101-06
8	Lock Ring	S1BW101-06
9	Lower Shock Mount	
10	Rear Spring	

## Original Suspension Removal

### Front

1. After safely placing the car on jack stands, Support Lower Control Arm/Spindle
2. Remove front brake calipers (18mm) and disconnect any lines (brake, ABS, Headlight level sensor (10mm)) from original suspension.
3. Remove sway bar end link from lower control arm. (16mm)
4. Remove outer tie rod end from spindle (18mm)
5. Remove pinch bolt (18mm) from spindle and using a Strut Spreader Tool, spread spindle mount.
6. At this point it would be beneficial to protect the outside lip/edge of the fender with painters tape or equivalent to help prevent scratching of paint while removing the original strut.
7. Lower the control arm to separate strut from spindle. (Fig.1 #15)
  - a. Ensure that the lower control arm is still supported
  - b. This may require work to separate as corrosion may limit movement
  - c. Using rubber mallet tap the cast spindle to free strut from spindle
8. Support strut from inside wheel well
9. Remove three (3) upper strut mount nuts (13 mm) (Fig.1 #3)
10. Remove strut assembly
11. Leave the Strut Spreader in place

***SOLO WERKS TIP:*** As the strut mounts are a consumable/wear item and are a known fail point on this chassis. Solo Werks recommends using new replacement parts and leaving your original suspension as an assembly. These parts are available from your Solo Werks Dealer or your local BMW parts dealer.

NOTE: If you are using your existing OEM upper strut mount (Fig. 1 #3) you must remove this from the strut assembly. This component is under extreme pressure from the front spring and must be removed using an appropriate spring compressor to relieve the pressure. Follow the directions given by the manufacturer of the Spring Compressor to safely remove the spring and disassemble the Strut Assembly.

## Solo Werks Coilover Pre Assembly – Priming the Dampers

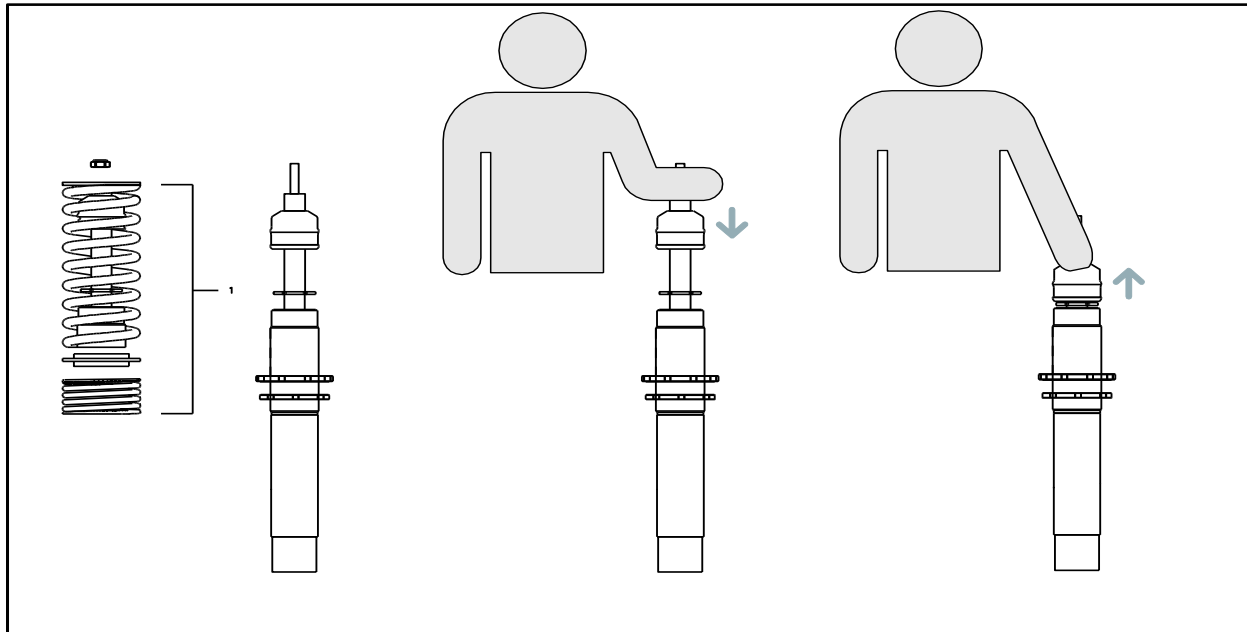

**SOLO WERKS TIP:** As the suspension is shipped and stored in a horizontal position, it is advisable to exercise or Prime the shock absorber before you install them to ensure that the internal contents are in the correct chambers. Therefore we advise that before you assemble the front coilover shock absorber, take a moment to purge the shock absorber.

To do this, one side at a time remove the following from one of the front Coilover Assemblies:

- Two Upper fasteners (lock nut and securing nut)
- Upper Spring Perch
- Main Spring
- Spring Isolator
- Helper Spring

You will then be left with the coilover strut with the bumpstop and vent disc on the shaft. Pull the bumpstop up to the top of the chrome shock shaft, just before the threaded portion.

With the shock upright (as it would be installed in the vehicle) compress the shock shaft until the bump stop touches the shock housing, and then pull to extend the shock shaft back to full extension.

Repeat 3-5 times. You will notice the shock forces getting progressively harder each time. Once they feel consistent each way, you are ready to install.

---

## Solo Werks Coilover Assembly and Installation

### Front

1. Assemble the coilover assembly with the OEM Strut Mount using the provided hardware as in the diagram (Fig. 1 )
  - a. The Non Nyloc nut that is on the shock shaft is used during transport purposes only to keep the assembly together and is not used in the final assembly.

NOTE: Use of an anti-corrosion spray such as the Boeshield T-9 on the threads & main perch/spring seat at this point can make the adjustment process much easier and will add an extra layer of protection. Boeshield T-9 is available from your Solo Werks dealer.

2. NOTE: Before proceeding with the next step, inspect the Spindle for debris (rust/dirt etc. as this can make installation difficult.
3. Insert Strut into spindle making sure housing is completely seated within spindle. (Fig.1 #15)
4. Remove strut spreader tool and insert OEM pinch bolt and nut, torque to spec.
5. Tighten three (3) upper strut mount nuts to proper torque specifications.
6. Reattach outer tie rod end.
7. Reattach brake caliper.
8. Reattach any brake, ABS lines, etc that were removed.
9. Repeat procedure on the other side of vehicle.
10. Adjust lower spring perch to desired vehicle height.

### Original Suspension Removal

**SOLO WERKS TIP:** *Access to upper shock mount nuts requires removal of trunk interior. Please refer to repair manual (i.e. Bentley Manual) for proper removal procedure.*

#### Rear

1. After the interior is removed and the three upper strut mount bolts (13mm) are removed you can now move onto the underside of the car.

**SOLO WERKS TIP:** *The removal and installation of the rear is easiest if you are able to disconnect the rear anti sway bar end links from the lower control arms.*

2. Be aware of any brake, ABS, leveling sensors, etc. that could get damaged during the removal process and unclip, detach accordingly to create more space.
3. Remove the lower strut mount bolt. (18mm)
4. While applying force down on the lower control arm via the brake assembly you will now be able to remove original strut from car.

## Solo Werks Coilover Assembly and Installation

### Rear

**SOLO WORKS TIP:** *Just like the front struts, it is advisable to Prime the rear shocks as well. To purge the rear shocks: Refer to procedure on page 5.*

#### Rear Shock Absorbers Assembly:

1. Assemble new Solo Werks rear shock absorber per the assembly diagram. (Fig. 2 #4,7&8)
2. Install shock into upper shock mount and tighten the three (3) shock mount nuts. (Fig. 2 #3)
  - a. Once vehicle is placed back on the ground torque upper shock mount nuts to proper torques settings.
3. Manipulate control arm until lower shock mount bolt can be reinstalled. (fig.2 #16)
  - a. Torque lower shock bolt to proper torque settings.
4. Replace sway bar end links.
5. Replace trunk interior to finalize installation.
6. Final check that all hardware is tight and torques properly.
  7. Adjust lower spring perch to desired vehicle height.

**SOLO WERKS TIP:** *It is advisable that all attaching hardware be checked after approx. 200 miles to ensure it has retained appropriate OEM torque settings.*



## Solo Werks Coilover Final Details – Heights & Working Ranges

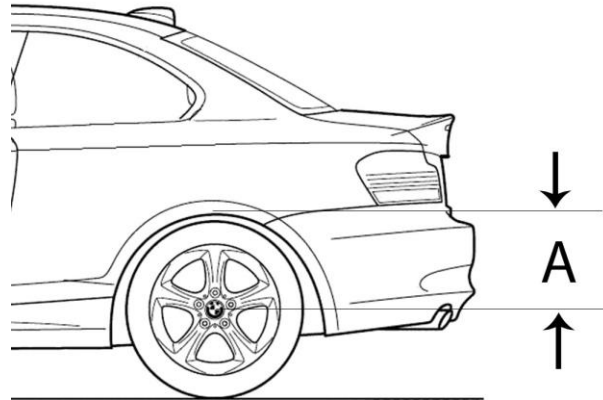

		Lowering Range			
		in mm		in Inch	
Model	Year	Front	Rear	Front	Rear
BMW E60 Sedan W/O OEM Sport package	04'-10'	25-55 mm	25-55 mm	1.0"-2.2"	1.0"-2.2"

Front Measurement					
Max low mm	Max low Inch	Max high mm	Max high Inch	OEM mm	OEM Inch
325 mm	12.75"	350 mm	13.75"	375 mm	14.75"

Rear Measurement					
Max low mm	Max low Inch	Max high mm	Max high Inch	OEM mm	OEM Inch
325 mm	12.75"	350 mm	13.75"	375 mm	14.75"

- These measurements are in place to allow both front and rear dampers to operate properly and allow for ample shock travel.
- All measurements will be referenced from "center of wheel hub to bottom lip of fender" (see example figure "a")
- Using this system outside of this range can cause premature failure and is cause to void your manufacturer specified warranty.
- Helper springs are intended to keep preload on the main spring under full suspension extension, do not remove!

## My Setup - Heights & Working Ranges

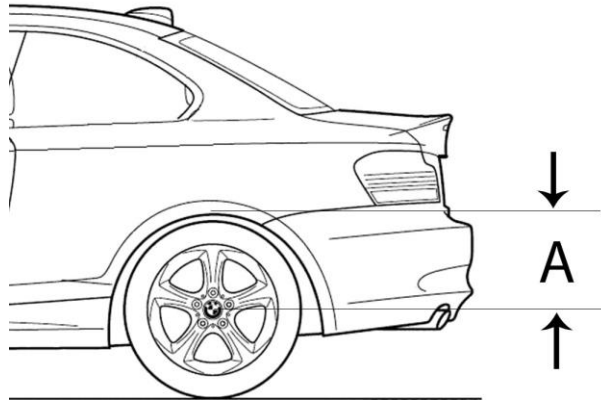

Use this page to record your setup heights for easy future reference

Front Measurement						
Date	Max low mm	Max low Inch	Max high mm	Max high Inch	OEM mm	OEM Inch
Solo Spec	325	12 3/4"	350	13 3/4"	375	14 3/4"

Rear Measurement						
Date	Max low mm	Max low Inch	Max high mm	Max high Inch	OEM mm	OEM Inch
Solo Spec	325	12 3/4"	350	13 3/4"	375	14 3/4"