

Thank you for purchasing your new SOLO WERKS S1 Coilover suspension.

IMPORTANT PLEASE READ BEFORE BEGINNING INSTALLATION:

Please take a moment to review this installation process and verify that your kit is complete and all components have been received. If there are any questions during the process, contact us directly.

SOLO WERKS recommends that you have this kit installed by a qualified professional. Solo Werks or its authorized agents are not responsible for damage or failure resulting from an improper or modified installation. Do not use a pneumatic impact gun to torque the upper strut nut as damage may occur.

All suspension related components must be inspected and in good working condition. You should inspect all bushings, tie rods, hubs, bearings, strut mounts, sway bar end links, wheels, tires, etc. and replace if necessary.

This suspension system was designed to work best with the factory wheel/tire combination. Any deviations from these specifications could result in significantly altered handling characteristics and/or increased interference risk to other vehicle components.

SOLO WERKS TIP: *Depending on the offset & size your wheels/tires, wheel spacers may be required for proper fitment.*

If suspension is lowered past the recommended measurements there can be possible interference with multiple vehicle components; (i.e. modification may be necessary to fender lips, seams etc.). This will also void your Solo Werks warranty.

After installing the suspension system, a four-wheel alignment must be performed according to manufacturer's specifications. Check and reset load- dependent brake compensator, ABS system and headlight aim according to manufacturer's specifications (If applicable).

ALL RUBBER- MOUNTED STRUT/ DAMPER ATTACH-MENTS MUST NOT BE FULLY TIGHTENED UNTIL AFTER THE SUSPENSION SYSTEM IS LOADED (WHEELS ON THE GROUND). OTHER MOUNTING FASTENERS (FOR EXAMPLE BRACKETS) MUST BE SECURELY TIGHTENED BEFORE LOAD IS PLACED ON THE SUSPENSION SYSTEM

Every effort has been made to avoid printing errors in our literature. However, if there are any application or specification errors or omissions we must disclaim responsibility.

Original Suspension Removal- Front:

SOLO WERKS TIP: *Disconnect Headlight level sensor on control arm (if equipped) before any other steps are taken. Disregard for this step could result in damage to sensor link.*

1. Support Lower Control Arm/Spindle with floor jack
2. Remove any lines/hoses from original suspension strut mounts
3. Remove OEM sway bar endlink from lower control arm
4. Disconnect tie rod end from steering knuckle
5. Disconnect upper control arms from steering knuckle
6. Remove three upper strut housing bolts that attach strut to the chassis
7. Remove Lower strut bolt/nut from lower control arm
8. While pushing down on the suspension you will now be able to remove the OEM strut as an assembly (strut housing, spring, upper strut mount, upper control arms)

NOTE: If you are using your existing upper strut mount, control arms (Fig 1 #2) you must remove these items from the strut assembly. These items are under extreme pressure from the front spring and must be removed using an appropriate spring compressor to relieve the pressure. Follow the directions given by the manufacturer of the Spring Compressor to safely remove the spring and disassemble the Strut Assembly.

SOLO WERKS TIP: *OEM suspension components such as strut mounts bearings, control arms, etc. are a consumable/wear item and are a known fail point on this chassis. Solo Werks recommends using new mounts with new OEM Bearings and leaving your original suspension as an assembly. These parts are available from your Solo Werks Dealer or your local VW/Audi parts dealer.*

Solo Werks Coilover Pre-Assembly – Priming the Dampers

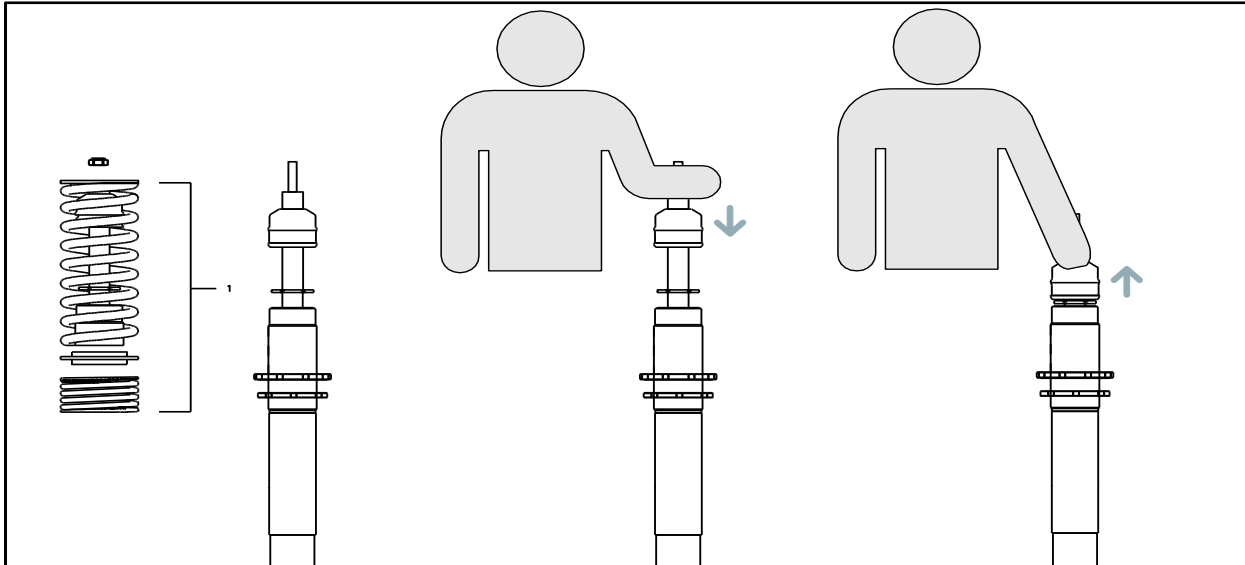

SOLO WERKS TIP: As the suspension is shipped and stored in a horizontal position, it is advisable to exercise or Prime the shock absorber before you install them to ensure that the internal contents are in the correct chambers. Therefore, we advise that before you assemble the front coilover shock absorber, take a moment to prime the shock absorber.

To do this, one side at a time remove the following from one of the front Coilover Assemblies (if equipped):

- Two Upper fasteners (lock nut and securing nut)
- Upper Spring Perch
- Main Spring
- Spring Isolator
- Helper Spring

You will then be left with the coilover strut with the bumpstop and vent disc on the shaft. Pull the bumpstop up to the top of the chrome shock shaft, just before the threaded portion.

With the shock upright (as it would be installed in the vehicle) compress the shock shaft until the bump stop touches the shock housing, and then pull to extend the shock shaft back to full extension.

Repeat 3-5 time minimums. You will notice the shock forces getting progressively harder each time. Once they feel consistent each way, you are ready to install.

Fig. 1 Front

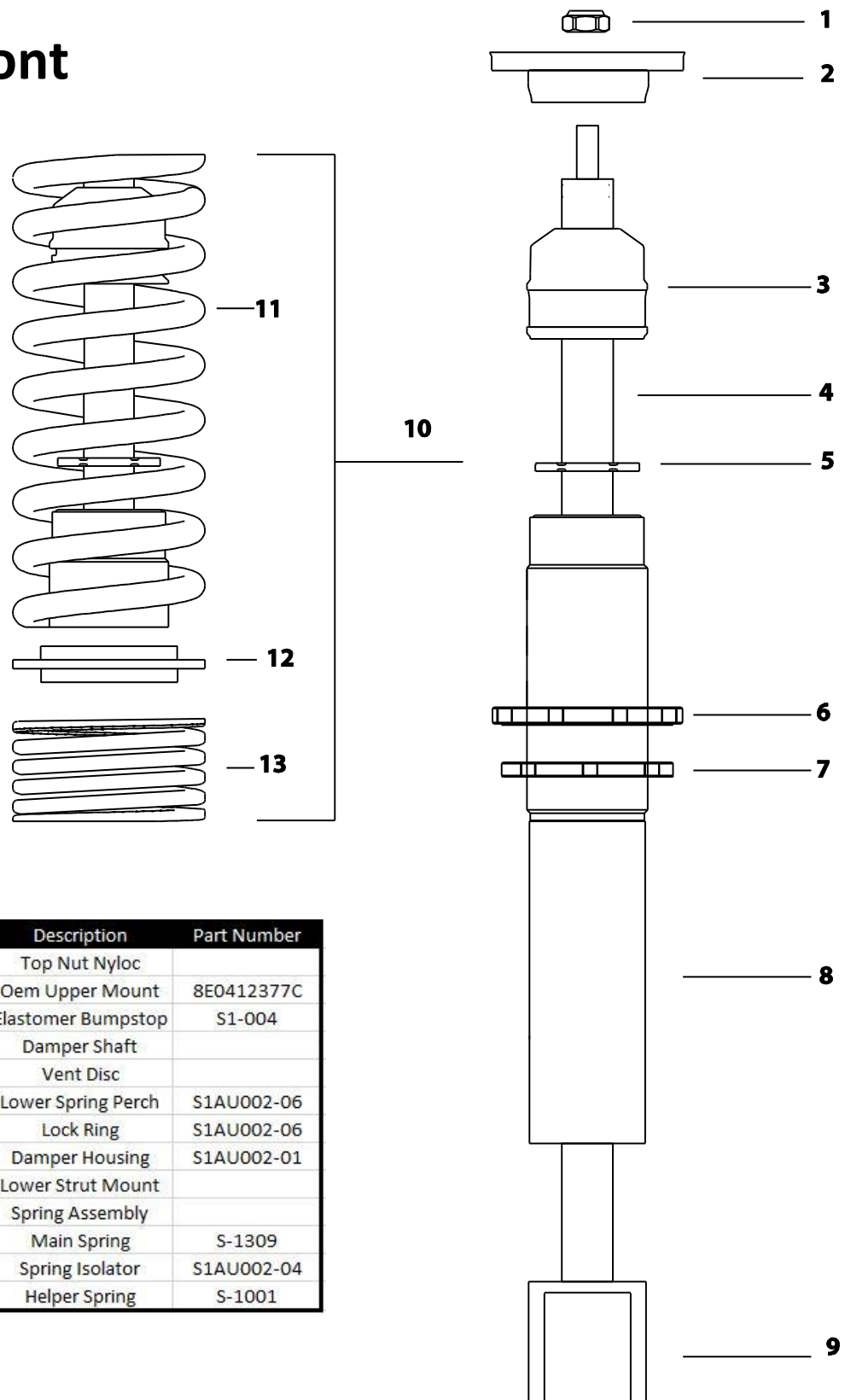

#	Description	Part Number
1	Top Nut Nyloc	
2	Oem Upper Mount	8E0412377C
3	Elastomer Bumpstop	S1-004
4	Damper Shaft	
5	Vent Disc	
6	Lower Spring Perch	S1AU002-06
7	Lock Ring	S1AU002-06
8	Damper Housing	S1AU002-01
9	Lower Strut Mount	
10	Spring Assembly	
11	Main Spring	S-1309
12	Spring Isolator	S1AU002-04
13	Helper Spring	S-1001

Fig. 2 Rear

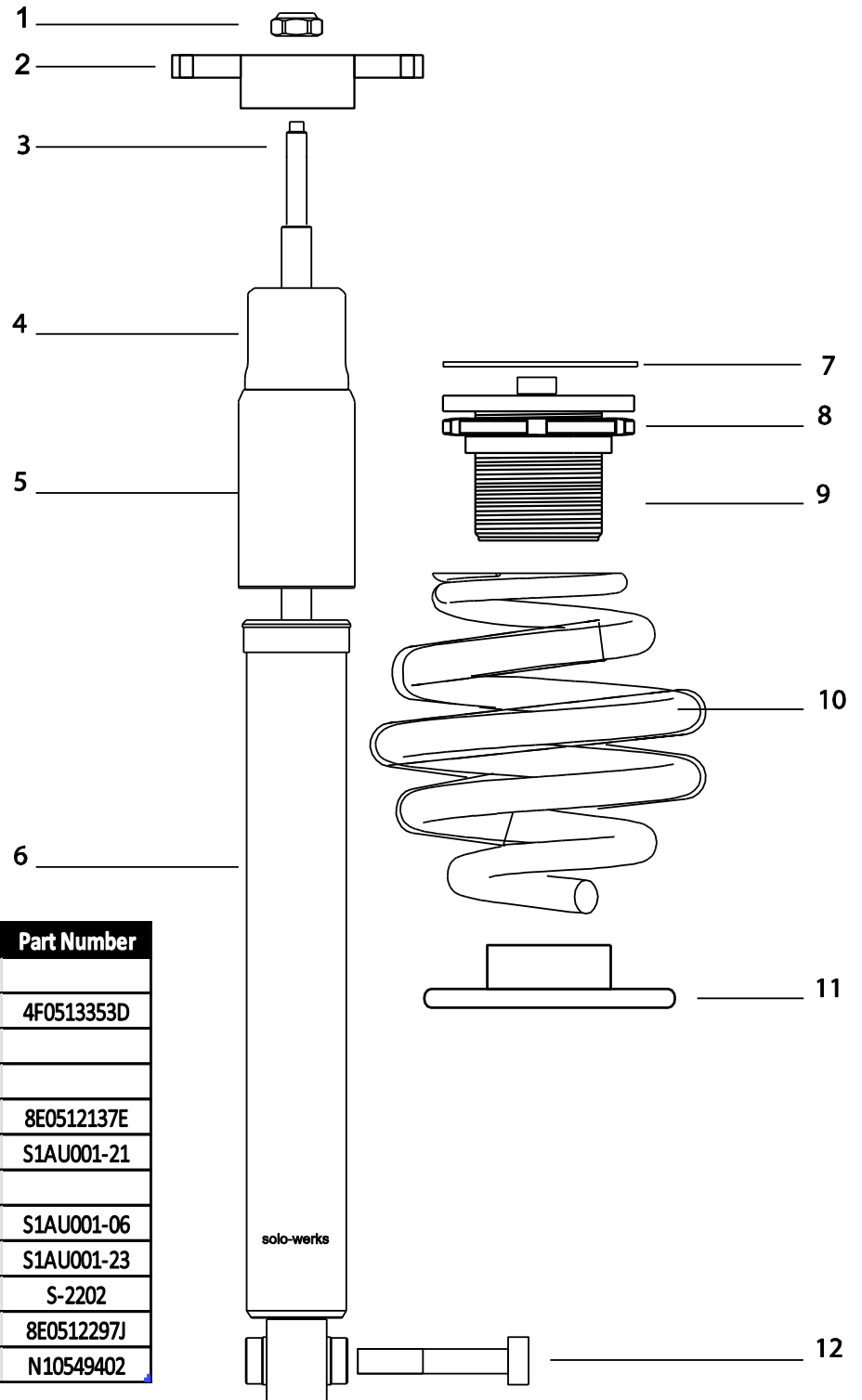

#	Description	Part Number
1	Top Nut Nyloc	
2	OEM Upper Shock Mount	4F0513353D
3	Damper Shaft	
4	OEM BUmpStop	
5	OEM Dust Shield	8E0512137E
6	Damper Housing	S1AU001-21
7	Spring Perch Isolator	
8	Rear Spring Perch/Lock Ring	S1AU001-06
9	Rear Adjustable Spring Perch	S1AU001-23
10	Rear Spring	S-2202
11	Oem Spring Pad	8E0512297J
12	OEM Lower Hex Bolt	N10549402

Solo Werks Coilover Assembly and Installation – Front:

- 1. Work in the OEM Upper Bearings - Rotate the bearing a few times to break it in**
 - a. We have found that brand new or even existing bearings can get stuck as they have a very limited rotation when installed**
 - b. If they are stuck or too hard to move, they will not allow the assembly to rotate as it should and will create a spring bind that will produce a “boing” or “clang” sound of the springs recoiling**

Assemble the coilover assembly with the OEM Strut Mount using the provided hardware as in the diagram Fig.1

- a. Top nut should be torqued to 44 ft-lbs. (Fig. 1 #1)
- b. Once assembled, we recommend starting the main perch at 25mm (1”) of thread remaining below the main perch/spring seat using the included spanner wrench – actual vehicle height will be set later in the process. (Fig.1 # 7&8)

NOTE: Use of an anti-corrosion spray such as the Boeshield T-9 on the threads & main perch/spring seat at this point (Fig.1 # 7&8) can make the adjustment process much easier and will add an extra layer of protection. Boeshield T-9 is available from your Solo Werks dealer.

2. Insert strut assembly into vehicle
 - a. Reinstall three upper strut mount bolts but do not tighten at this time.
3. NOTE: Before proceeding with the next step, inspect the lower control arm is clean and free of debris (rust/dirt etc. (Fig.1 #10) before installation of the new strut assembly.
4. Raise suspension and reinstall bottom strut mount bolt into lower control arm
 - a. Do not torque at this time (Fig.1 #10)
5. Reinstall upper control arms into steering knuckle
6. Reinstall tie rod end into steering arm
7. Reinstall sway bar endlink to lower control arm and torque to 30 ft.-lbs.
8. Reconnect any lines/hoses or headlight sensors
9. Once vehicle is placed back on the ground under its own weight, Torque upper strut mount bolts to 50 ft-lbs and bottom strut bolt to 66 ft-lbs.
10. Make sure all attaching bolts are torqued properly

Original Suspension Removal- Rear:

SOLO WERKS TIP: *Disconnect Headlight level sensor from lower control arm before any other steps are taken. Disregard for this step could result in damage to sensor link.*

1. While Supporting lower trailing arm in the compressed position (loaded as if it is on the ground)
 - a. Remove (2) upper shock bolts holding upper shock mount (Fig.2 #2)
 - b. Remove lower shock bolt and remove shock from vehicle (Fig.2 #12)
 - c. Slowly lower rear trailing arm on both sides to remove the pressure on the rear springs
 - d. Remove oem upper shock mount and dust boot/bumpstop assembly (To be reused)
 - e. Make note of orientation of OEM parts to be reinstalled later. (Fig.2 #2)
2. Disconnect sway bar endlink from lower control arm
3. To help relieve tension and aid in removal of the rear springs the rear sub frame will now need to be “lowered”.
 - a. Locate the Four mounting bolts (two per side w/ large washers)
 - b. Do not remove the bolts but back them out approx. 2” to allow sub frame to “hang”
 - c. It may also be necessary to remove the upper arm bolt from the rear knuckle (this is the bolt where camber adjustment is made)
4. As this is a stubborn process, the use of a spring compressor is also sometimes needed
5. Remove rear coil spring

Solo Werks Coilover Assembly and Installation – Rear:

The Rear of this platform is a combination of a rear lowering spring & adjustable spring perch and specially matched shock absorber. The shock absorber does not need to be adjusted in any way to change the ride height.

SOLO WORKS TIP: *Just like the front struts, it is advisable to Prime the rear shocks as well. To purge the rear shocks: Refer to procedure on page 3.*

In the vertical position (as it would be installed in the vehicle):

1. Extend the shock rod to its full extent
2. Compress until 1” of the chrome shock rod is visible outside of the shock housing
3. Repeat 3-5 times or until the strokes feel consistent.

Solo Werks Coilover Assembly and Installation – Rear con't.

1. Remove both upper and lower factory spring pads from the vehicle, and ensure that both areas are clean and free of any dirt or debris.
2. Reinstall lower OEM spring pad and install new spring. (Fig.2 #11&10)
 - a. Install adjustable spring perch onto top of spring (Fig.2 #9)
3. Tighten four sub frame bolts to 65 ft.-lbs.

Solo Werks Tip: *On Quattro models make sure the supplied rubber spring perch isolator is installed in-between the chassis and the adjustable spring perch. (Fig. 2 #7)*

4. Assemble Solo-Werks rear shock (Fig.2) reusing OEM upper shock mount, Bump stop and Dust shield. Torque shock shaft nut (Fig.2 #1) to 18 ft.-lbs.
5. Place shock into vehicle and reinstall two upper shock mount bolts and torque to 26 ft.-lbs.
6. Re install the lower bolt / lock washer / washer assembly through the opening in the bottom of the control arm/axle.
 - a. Do not torque lower shock bolts until vehicle is back on the ground and all weight is on vehicle.
 - b. Torque lower shock bolts to 90 ft.-lbs.

Solo Werks Tip: *When bolting in the lower perch, use a small amount of thread locker on the bolt to ensure that it does not rattle free during use (i.e. Loctite Blue 242)*

7. Reattach sway bar endlink and torque to 30 ft.-lbs.
8. Make sure all attaching bolts are torqued properly
9. Adjust final height

Solo Werks Coilover Final Details – Heights & Working Ranges

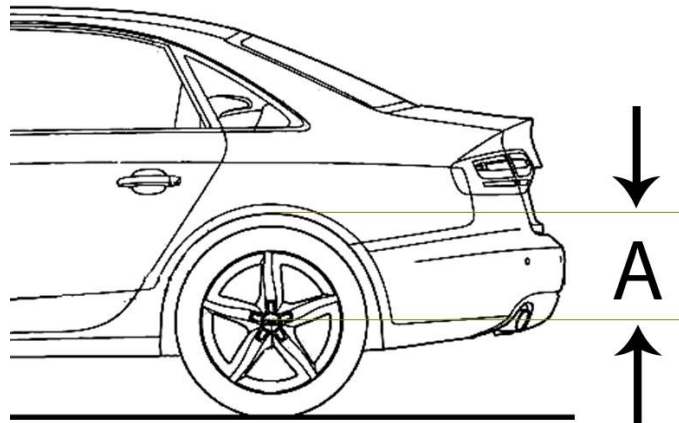

		Lowering Range			
		in Mm		in Inch	
Model	Year	Front	Rear	Front	Rear
Audi B6/7 A4 Q Sedan	01'-07'	40-80mm	40-80mm	1.6"-3.35"	1.6"-3.35"

Front Measurement					
Max low mm	Max low Inch	Max high mm	Max high Inch	OEM mm	OEM Inch
305mm	12"	350	13.75"	390	15.35"

Rear Measurement					
Max low mm	Max low Inch	Max high mm	Max high Inch	OEM mm	OEM Inch
305mm	12"	350	13.75"	390	15.35"

- These measurements are in place to allow both front and rear dampers to operate properly and allow for ample shock travel.
- All measurements will be referenced from "center of wheel hub to bottom lip of fender" (see example figure "a")
- Using this system outside of this range can cause premature failure and is cause to void your manufacturer specified warranty.
- Helper springs are intended to keep preload on the main spring under full suspension extension, do not remove!

My Setup - Heights & Working Ranges

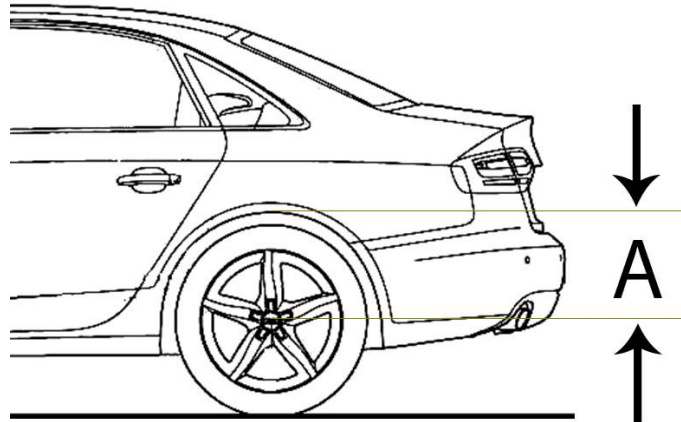

Use this page to record your setup heights for easy future reference

Front Measurement						
Date	Max low mm	Max low Inch	Max high mm	Max high Inch	OEM mm	OEM Inch
Solo Spec	305	12"	350	13 3/4"	390	15 1/4"

Rear Measurement						
Date	Max low mm	Max low Inch	Max high mm	Max high Inch	OEM mm	OEM Inch
Solo Spec	305	12"	350	13 3/4"	390	15 1/4"