



# *Wheel Charger Owner's Manual*



Includes information on SOLAR Model Nos. OS6110, OS6120, OS6130, OS6140 and OS6150

**⚠WARNING**



Failure to follow instructions may cause damage or explosion, always shield eyes.  
**Read entire instruction manual before use.**







**Warning:** This product contains chemicals, including lead, known to the State of California to cause cancer, birth defects and other reproductive harm.  
***Wash hands after handling.***

Congratulations on the purchase of your new battery charger. We wish to acknowledge Underwriters Laboratories (U/L) for contributing the following important safety precautions. Please read and retain these instructions for the continued safe use of your new charger.

This manual contains important safety information. **DO NOT OPERATE** this equipment UNTIL YOU HAVE READ this safety summary!

## SAFETY SUMMARY

### IMPORTANT SAFETY INSTRUCTIONS SAVE THESE INSTRUCTIONS

<b>⚠ WARNING</b>	
	Read these instructions completely before using the <b>SOLAR</b> Battery Charger and save them for future reference. Before using the <b>SOLAR</b> Battery Charger to charge a battery, read these instructions and the instruction manual/safety information provided by the car, truck, boat or equipment manufacturer. Following all manufacturers' instructions and safety procedures will reduce the risk of accident.
	Working around lead-acid batteries may be dangerous. Lead-acid batteries release explosive gases during normal operation, charging and jump starting. Carefully read and follow these instructions for safe use. Always follow the specific instructions in this manual and on the <b>SOLAR</b> Battery Charger each time you use the <b>SOLAR</b> Battery Charger. All lead-acid batteries (car, truck and boat) produce hydrogen gas which may violently explode in the presence of fire or sparks. <b>Do not smoke, use matches or a cigarette lighter while near batteries.</b> Do not handle the battery while wearing vinyl clothing because static electricity sparks are generated when vinyl clothing is rubbed. Review all cautionary material on the <b>SOLAR</b> Battery Charger and in the engine compartment.
	Always wear eye protection, appropriate protective clothing and other safety equipment when working near lead-acid batteries. Do not touch eyes while working on or around lead-acid batteries.
	Always store clamps away from each other or common conductors. Improper storage of clamps may cause the clamps to come in contact with each other, or a common conductor, which would be hazardous if the charger was plugged into an AC outlet.
	Use extreme care while working within the engine compartment, because moving parts may cause severe injury. Read and follow all safety instructions published in the vehicle's Owner's Manual.
	Batteries being charged with the <b>SOLAR</b> Battery Charger unit likely contain liquid acids which are hazardous if spilled.

**WARNING:** This product contains chemicals, including lead, known to the State of California to cause cancer, birth defects and other reproductive harm. **Wash hands after handling.**

## WARNING – Shock Hazards

1. This battery charger is intended for indoor use only. Do not expose the charger to rain or snow.
2. **NEVER** attempt to charge a marine (boat) battery while the boat is on or near the water. A boat must be on a trailer and located indoors before attempting to charge its battery(s). The boat manufacturer’s battery charging instructions must be followed exactly.
3. **NEVER** set the charger, output cable or clamps, or ac power cord plug in water or on wet surfaces.
4. **NEVER** use this charger on a pier or dock. Charger could fall in water, creating an electric shock hazard.
5. **NEVER** attempt to plug in or operate the battery charger with defective or damaged wires, power cord, or power cord plug. Have any of these parts that are defective or damaged replaced by qualified personnel IMMEDIATELY.
6. **NEVER** attempt to plug in the charger or operate its controls with wet hands or while standing in water.
7. **NEVER** alter the ac power cord or power cord plug provided with the battery charger.
8. **NEVER** use an attachment not recommended or sold by Clore Automotive for use with this specific model battery charger. Use of such attachment may result in risk of fire, electric shock or injury to persons.
9. **NEVER** operate this battery charger if it has received a sharp blow, been dropped, or similarly damaged, until after being inspected and/or repaired by qualified service personnel.
10. **NEVER** disassemble this battery charger. Take the battery charger to qualified service personnel when service or repair is needed.
11. **ALWAYS** plug in and unplug the AC power cord by grasping the power cord plug, NOT THE POWER CORD, to reduce risk of damaging power cord.
12. **ALWAYS** unplug the battery charger from the ac outlet before attempting any cleaning or maintenance. Turning the charger’s control(s) OFF, alone, will not remove all electricity from the charger.
13. An extension cord should not be used unless absolutely necessary. Use of an improper extension cord could result in a fire or electric shock. If an extension cord must be used, make sure that:
  - a. That pins on plug of extension cord are the same number, size, and shape as those of plug on charger,
  - b. That extension cord is properly wired and in good electrical condition; and
  - c. That the wire size is large enough for the length of cord as specified below:

<i>Length of cord in feet:</i>	25	50	100	150
<i>AWG size of cord:</i>	16	12	10	8

## WARNING – Risk of Explosive Gases

1. Working in the vicinity of a lead-acid battery is dangerous. Batteries generate explosive gasses during normal operations and, at an even higher level, during charging. If anything is allowed to ignite these gasses, the battery may explode, sending pieces of the battery and extremely caustic battery acid out in all directions and with extreme force. Since just the slightest spark is sufficient to ignite these gasses, it is of **UTMOST IMPORTANCE** that you read this manual and follow the instructions exactly, before using your battery charger.
2. **NEVER** operate this battery charger near any fuel tanks or gas cylinders. This charger can produce sparks that could ignite gasses and cause an explosion.
3. **NEVER** attempt to permanently mount this battery charger on a marine or recreational vehicle.
4. **NEVER** attempt to connect this charger’s output cables directly to the battery(s) in the bilge or engine compartment of a boat. Follow the boat manufacturer’s battery charging instructions exactly.

## **WARNING – Battery Explosion Hazards**

1. **NEVER** connect both battery charger clamps directly to the two posts of the same battery. See *Operation Instructions* for connection procedures.
2. **NEVER** allow the dc output clamps to touch each other.
3. **ALWAYS** be extra cautious to reduce the risk of dropping a metal object, such as a tool, onto or near the battery. Doing so could produce a spark or short circuit the battery or other electrical part that could cause an explosion.
4. **NEVER** operate the battery charger in a closed-in area or restrict ventilation in any way.
5. **ALWAYS** make sure the area around a battery is well ventilated while it is being charged. Gas can be forcefully blown away by using a piece of cardboard or other non-metallic material as a fan.
6. **ALWAYS** make sure that the AC power cord is unplugged from the ac outlet or extension cord BEFORE connecting or disconnecting the battery charger clamps, to prevent arcing or burning.
7. **ALWAYS** locate the battery charger as far away from the battery as the DC output cables will permit.
8. **ALWAYS** twist or rock charger clamps back and forth several times on the battery post and the other point of connection at the time of initial connection. This helps keep the clamps from slipping off their points of connection which helps reduce the risk of sparking. DO NOT rock the clamp connected to the battery post AFTER the second connection (at a point away from the battery) is made or sparking may occur at the battery post.
9. **ALWAYS** check the cable and wire connections at the battery(s) for tightness BEFORE starting to charge. A loose connection can cause sparks or excessive heating which could cause a battery explosion.
10. **ALWAYS** make sure the battery compartment is open and well ventilated before charging.

## **WARNING – Moving Parts Hazards**

1. **NEVER** connect the battery charger clamps to a vehicle when the engine is running.
2. **ALWAYS** stay clear of fan blades, fan belts, pulleys and other moving engine parts when working near an engine. Moving engine parts can cause severe personal injury, including dismemberment.
3. **ALWAYS** make sure that the battery charger cables and clamps are positioned so they will not come in contact with any moving engine parts.
4. **NEVER** wear loose clothing or long hair around moving parts because they may get caught and cause severe injury or death.

## **WARNING – Burn Hazards**

1. **NEVER** lean on or rest against the engine or cooling system parts when the vehicle is running.
2. **ALWAYS** stay clear of the cooling system, engine, and engine manifold. These engine components get very hot and retain heat for a long time. Touching any of these components can cause severe burns.

## PERSONAL PRECAUTIONS

1. Someone should be within range of your voice or close enough to come to your aid when you work near a lead-acid battery.
2. Have plenty of fresh water and soap nearby in case battery acid contacts skin, clothing, or eyes.
3. Wear complete eye protection and clothing protection. Avoid touching eyes while working near battery.
4. If battery acid contacts skin or clothing, wash immediately with soap and water. If acid enters eye, immediately flood eye with running cold water for at least 10 minutes and get medical attention immediately.
5. **NEVER** smoke or allow a spark or flame in vicinity of battery or engine.
6. Be extra cautious to reduce risk of dropping a metal tool onto battery. It might spark or short-circuit battery or other electrical part that may cause explosion.
7. Remove personal metal items such as rings, bracelets, necklaces, and watches when working with a lead-acid battery. A lead-acid battery can produce a short-circuit current high enough to weld a ring or other jewelry to metal, causing a severe burn.
8. Use charger for charging LEAD-ACID batteries only. It is not intended to supply power to a low voltage electrical system other than in a starter-motor application. Do not use battery charger for charging dry-cell batteries that are commonly used with home appliances. These batteries may burst and cause injury to persons and damage to property.
9. **NEVER** charge a frozen battery, as battery explosion can result.

# TABLE OF CONTENTS

## SAFETY SUMMARY

Safety Information .....	2
Shock Hazards .....	3
Explosive Gas Hazards .....	3
Battery Explosion .....	4
Moving Parts Hazards .....	4
Burn Hazards .....	4
Personal Precautions .....	5

## INTRODUCTION

Description .....	8
How Batteries Charge .....	8
Deeply-discharged Lead-Calcium Batteries .....	8
Spark Prevention .....	8

## ASSEMBLY

Assemble the Handle .....	9
---------------------------	---

## PREPARATION

Charger Placement .....	10
Provide Required Power .....	10
Extension Cords .....	10
Battery Preparation .....	11

## CONTROLS AND INDICATORS

Control Setting Instructions .....	12
Charge Voltage and Rate Selection .....	12
Timer Switch Setting .....	13
Voltmeter/Test Meter Testing .....	13
Battery Percent of Charge Test (12 Volt only) .....	13
Alternator Test (12 Volt only) .....	14
Pre-Charge Battery Activation .....	14
Manual-to-Automatic Models .....	14

**OPERATION**

Operating Instructions .....15  
    *Connecting to Batteries Installed in Vehicles* .....15  
    *Connecting to Batteries Outside a Vehicle* .....15  
Charging Instructions .....16  
Reading an Ammeter .....16  
Charging Time Instructions .....17  
Engine Starting .....20

**MAINTENANCE**

Maintenance .....21

**TROUBLESHOOTING**

Troubleshooting .....21

# INTRODUCTION

## Description

This battery charger is designed to handle the majority of your charging and starting needs.

- Multiple Charge Rates for various battery sizes.
- High-Amperage Engine Start to help start vehicles when the battery is too weak to do the job alone.
- An Ammeter to monitor charging progress.
- A Timer switch (some units) to set the desired charge time (some with an AUTO MODE charge position).
- Large Saw-Tooth Clamps assure good connection to top or side-mount battery terminals.
- Wheel and Handle Kit for easy moving around your shop.
- Heavy-Duty Construction for long, trouble-free life.

## How Batteries Charge

A charger does not *force* current into a battery – it makes a limited amount of current available and the battery draws as much of it as it needs, up to or slightly greater than the rated output current capability of the charger.

The closer a battery is to zero capacity (dead battery), the more charging current it will want to draw. When charging begins, on a dead battery, the charger's ammeter will register toward the high end of the scale and move toward zero as the battery becomes more fully charged. Keep in mind, the ammeter registers the amount of amperage being drawn from the charger by the battery, not what the charger is capable of delivering.

One would expect a battery to draw zero amps when it reaches 100% charge. But at 100% charge, the battery will continue to draw a low level of current and convert it into heat within the battery. If left connected and charging after reaching 100% charge, the battery acid will begin to boil, may produce acid vapor and get hot, resulting in overcharging and possible battery damage.

*Note: A slow, intermittent bubbling sound may be heard coming from the battery during the charging process. This is a normal condition and just another indicator the battery is being charged.*

To reduce the risk of battery overcharging, it is important to thoroughly read this instruction manual.

## Deeply-Discharged Lead-Calcium Batteries

Many newer automotive batteries are of a lead-calcium plate design. When deeply discharged, they may require an activation period before accepting a measurable charge. This activation period may take as long as 4 to 8 hours.

If, at the beginning of the charging process, you notice that the ammeter (if so equipped) is at or near zero, but you have determined that the battery is very discharged (less than 25% of charge), this is a good indication that an activation period is required (see Pre-Charge Battery Activation).

## Spark Prevention

Make sure no sparks or flames occur near the battery, especially during charging. It takes very little to ignite the explosive gasses produced by a lead-acid battery during the charging process. Read, understand and follow the safety information provided in the **Safety Summary** section of this manual before attempting to work with or near a lead-acid battery.

For more information about batteries and battery charging, contact Battery Council International at (312) 644-6610, and request their Battery Service Manual, which is available for a nominal charge.



# ASSEMBLY

## Assemble the Handle

Assemble the charger handle according to the following instructions and illustrations.

1. Carefully remove the charger unit and all associated hardware from carton.

### Remove the Screws

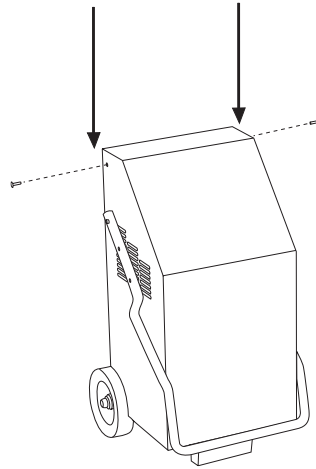

Figure 1. Remove the screws

2. Unscrew the two screws on either side of the charger as shown in Figure 1. They are the screws nearest to the top and towards the rear of the unit.

### Lift the Handle Into Position

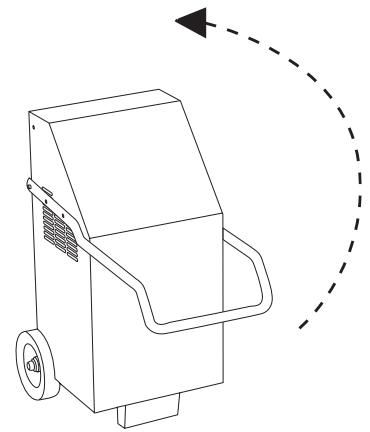

Figure 2. Lift the handle

3. The charger is shipped with the handle partially secured and resting in a down position on the front of the unit. Lift the handle on its axis, up and over the front of the charger into a vertical position, perpendicular to the top of the unit.

### Secure the Handle

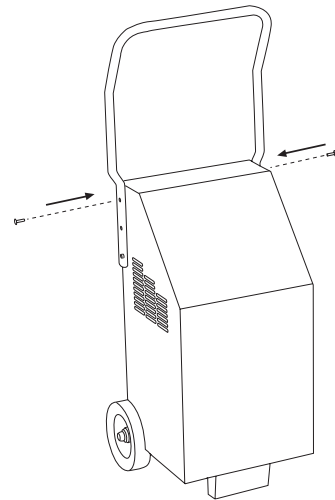

Figure 3. Secure the handle

4. Align the holes in the handle with the screw holes on the side of the charger (the same holes from which you just removed the two screws in step 2). Secure the two screws back into their original holes, thus securing the handle (Figure 3).

# PREPARATION

## Charger Placement

Place the charger in a clean, dry, stable, well-ventilated spot as far from the battery as the DC output cables permit.

**NEVER** place the charger directly above the battery being charged; gasses from the battery will corrode and damage the charger.

**NEVER** allow battery acid to drip on the charger when reading specific gravity or filling the battery.

**NEVER** place a battery on top of the charger.

**NEVER** attempt to permanently mount this battery charger on a marine or recreational vehicle.

**ALWAYS** position the charger on the outside of a boat or recreational vehicle.

## Provide Required Power

This battery charger requires a nominal 120V 60Hz alternating current (AC) power source. The power source must be fused at an amperage greater than or equal to the input amps rating of this charger.

Do not plug the charger into the AC power source until told to do so in the operating instructions.

**WARNING: ELECTRIC SHOCK CAN KILL!**  
**See complete warning on page 3.**

To reduce risk of electric shock, never alter AC power cord or power cord plug provided on the charger. If it will not fit the outlet, have a proper outlet installed by a qualified electrician. Never use an adapter.

The charger must be grounded to reduce risk of electric shock. The charger is equipped with an electric cord that has an equipment grounding plug. The plug must be plugged into an AC outlet that is properly installed and grounded in accordance with all local codes and ordinances.

## Extension Cords

*Note: Engine starting performance may be reduced when extension cords are used.*

An extension cord should not be used unless absolutely necessary. If necessary, care must be taken to select an extension cord suitable for use with your specific battery charger (see Shock Hazards in Safety Summary).

**WARNING: Fire can kill, injure and cause property damage!**  
**See Safety Summary, pages 2-4.**

To reduce risk of electric shock and fire, never alter the AC power cord or power cord plug provided on the charger. Never alter extension cords or extension cord plugs. Make sure the extension cord is properly wired and in good electrical condition. Make sure the wire size (American Wire Gauge or AWG) of the extension cord is large enough to handle your specific charger's amperage requirements.

## Battery Preparation

**WARNING: Battery explosion can injure and cause property damage! Never smoke or allow a spark or flame in the vicinity of the battery or engine.**  
**See Safety Summary, pages 2-4.**

If it is necessary to remove the battery from the vehicle to charge it, make sure all accessories in the vehicle are off and always remove the grounded cable from the battery first.

If needed, add distilled water to each cell of the battery until battery acid reaches the manufacturer's specified level. **DO NOT OVERFILL!** This helps remove excessive explosive gasses from the battery. For maintenance free batteries without caps, carefully follow the battery manufacturer's recharging instructions.

**WARNING: Battery acid can cause serious injury and property damage!**  
**See Safety Summary, pages 2-4.**

Always wear complete eye and clothing protection and avoid touching eyes while working near battery.

Clean battery terminals. Be careful to keep corrosion from coming in contact with eyes.

Study all of the battery manufacturer's precautions, such as whether cell caps should be left in place or removed during charging, and the recommended rates of charge for the specific battery. If you are unable to determine the battery manufacturer's requirements for charging, always charge the battery with cell caps in place.

If the battery voltage cannot be determined from the information on the battery itself, refer to the owner's manual for the product in which the battery was installed.

# CONTROLS AND INDICATORS

**Charge Rate Selector** switch is a multiposition rotary switch in most of the chargers. The available settings for each charger are described in Table 1 using Figure 4 to identify the switch positions.

Table 1. Charge Rate Selector Switch Settings

Model Number	Charge Rate Selector Switch Settings					
	A	B	C	D	E	F
OS6110	OFF	12V Low	12V Med.	12V High	12V Start	None
OS6120	6V High/Start	12V Low	12V Med.	12V High	12V Start	OFF
OS6130	OFF	6V High/Start	12V Low	12V Med.	12V High/Start	None
OS6150	OFF	6V High/Start	12V Med.	12V High/Start	24V High	None
OS6140	Rheostat from 0 Amps to max. Amps					

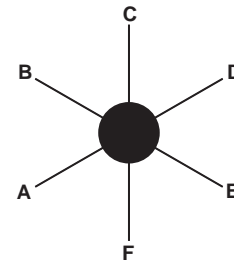

Figure 4. Rate Selector Switch.

**Timer** (most models) switch allows the selection of any charging time, up to 120 minutes. When the selected time is up, the timer automatically shuts the charger OFF. On manual to automatic Model OS6140, the charger switches to an automatic on/off mode that will start and stop charging as the battery requires.

**Ammeter** indicates the charging current being drawn from the charger by the battery. See *Reading an Ammeter* in this manual.

**Voltmeter** the voltmeter (if so equipped) will indicate voltage whenever the charger is turned on, or when the clamps are connected to a battery. If the unit is turned on and connected to a battery, it will read the combined voltage of the battery and the charger. If there is no reading when connected to a battery, check the connections and/or the battery.

**Volt Selector** (Model OS6140 only) allows the selection of 6 Volt or 12 Volt charging. This switch also has an OFF position to turn the charger OFF.

**Voltmeter/Test Meter** (if so equipped) the combination test meter/voltmeter on the front of the charger is used to read the voltage across the battery charger clamps.

## Control Setting Instructions

### Charge Voltage and Rate Selection

Set the Rate Selector to the same voltage and charge rate that is appropriate for the size and type of battery being charged. Use the battery manufacturer's specific instructions or see the guidelines below. If the battery voltage is not clearly marked on the battery, refer to the operator's manual for the vehicle/equipment where the battery is used/intended to be used. Do not begin charging if the battery voltage cannot be determined. The available settings are in Table 1.

Small Motorcycle type		3 Amps or less
Lawn mower/tractor	6	Amps or less
Deep-cycle		25 Amps or less
Maintenance-free Automotive or Marine Cranking		45 Amps or less
Heavy-duty Commercial		60 Amps or less

For Model OS6140, set the Volt Selector to the proper voltage. While monitoring the ammeter, turn the Rate Selector until the ammeter stops increasing, but do not exceed the maximum charge rate recommended by the battery manufacturer or the chart above. See *Timer Switch Setting* for information about 10 Amp automatic on/off mode.

Unless the information is supplied for the particular battery, always charge small 12 Volt batteries at no more than 2 Amps. Not all of these chargers are capable of charging at 2 Amps or less. If your charger does not feature a 2 Amp setting, do not attempt to charge small 12 Volt batteries on that charger. Charge only standard sized 6 and 12 Volt automobile batteries on those chargers.

*Note: The charger ammeter will not taper on 6 volt settings. Use charging time equations or charts only to determine the time needed to fully charge the battery.*

## Timer Switch Setting

Set the timer for the length of charging time required to bring the battery to full charge, as determined in *Charging Time Instructions*. When selecting times less than 20 minutes, turn timer past the 20-minute mark, then back to the time desired. Setting the time to charge starts the charging process. To prevent overcharging, do not set the timer for more time than it will take to bring the battery to full charge. If the timer is turned to the left, past OFF, HOLD is selected. In this position, the charger will remain ON indefinitely. This position should be used only when charging at a low rate for extended periods. The battery can be damaged when being charged for extended periods, especially at higher amperages.

Model OS6140 is a manual to automatic charger. When the timer has been set to any time up to 120 minutes, this charger is in a manual mode and the charging rate is controlled by the Rate Selector. When the timer returns to zero time, instead of shutting off, the charger switches to a 10 Amp automatic mode. In this mode, charging will continue until the battery reaches full charge. At full charge, the output from the charger is shut off. If left connected, the charger will continue to monitor the charge level of the battery and will resume charging if the battery discharges for any reason. A battery can be charged completely in the automatic mode by setting the Timer to automatic. When in automatic, the Rate Selector is no longer in control of the charging rate. Because the automatic charge rate is 10 Amps, small motorcycle type batteries should not be charged in the automatic mode.

## Voltmeter/Test Meter Testing

The Voltmeter/Test Meter, available on some models, allows additional testing to be performed. In normal operation, without the Test Switch pressed, the meter reads from 0-20 volts DC (0 and 20 are not actually seen on the meter face but are represented by the ends of the scale), on the lower scale of the meter. Using this part of the meter, during charging, the voltage should read:

- for 6 Volt batteries read 6.5 to 8.5 Volts
- for 12 Volt batteries read 13.5 to 16.5 Volts

If the voltmeter reads outside these voltages, refer to the chart below for possible battery conditions:

Volts low, Amps high	Probable shorted battery – replace
Volts low, Amps low	Poor connection or frozen battery
Volts high, Amps low	Battery cold or sulfated – reduce charge rate and charge longer

After charging is complete, the voltmeter should read the full charge voltage of the battery. This is normally higher than the rated battery voltage. To perform testing functions, press the Test Switch and read the top scale on the meter.

*Note: This type of repair work is rather specialized. It may require additional tests using other instruments for complete diagnosis. Remember, the charger must be turned OFF to perform the tests. If attempting to test with the charger ON, the results will be meaningless.*

## Battery percent of charge test (12 Volt only)

1. With the charger OFF and clamps properly connected to the battery, press the Test Switch and read the battery percent of charge on the top left scale of the test meter.
2. If the battery has been recently charged or is in a vehicle that has been run recently, there is probably a surface charge on the battery. This will give a falsely high reading on the percent of a charge test. Remove the surface charge by turning on the vehicle headlights for three or more minutes. Allow the battery to sit for one minute. Retest the battery percent of charge.

### **Alternator test (12 Volt only)**

1. With the charger OFF and clamps properly hooked to the battery, start the engine and while running at fast idle, press the Test Switch.
2. Read the alternator condition on the alternator test scale at the upper right section of the test meter. The battery should be in a good state of charge before attempting this test.
3. The three zones of the meter indicate the following:
  - OK: Charging system is performing properly
  - LOW: Loose fan belt, or voltage regulator and/or alternator faulty
  - HIGH: Faulty voltage regulator or wiring harness

### **Pre-Charge Battery Activation**

Some modern batteries can cause charging problems if they have been deeply discharged. The plates in these batteries can begin sulfating quickly, forming a barrier to accepting a charge. This condition will be indicated by an extremely low (or zero) ammeter reading. A deeply discharged battery such as this may take as long as 4 to 8 hours before it will accept a charge. When charging a battery with this condition, set the Rate Selector for a moderate charge rate and check on the battery every 30 minutes. When the sulfate barrier has been broken through, the battery will begin accepting a charge and the ammeter will register a higher, normal charging rate. The amount of time to charge the battery fully (determined in *Charging Time Instructions*) begins when the battery begins accepting a charge. If necessary, reset the timer (if your charger is so equipped) to the length of charging time required, after the battery begins accepting a charge.

### **Manual-to-Automatic Models**

When pre-charge battery activation is required for the OS6140 automatic model, charging will not begin in the automatic on/off mode. Always perform pre-charge battery activation in manual by setting the timer for 30 minutes at a time. When the ammeter indicates that the battery is accepting a charge, reset the timer for the desired length of manual charging time, or select automatic on/off if you desire immediately automatic control over the charging process.

# OPERATION

## Operating Instructions

**ATTENTION:** Do not attempt to operate this battery charger until you have read and understood the entire *Safety Summary* provided in this manual.

*Note:* Go to *Assembly* in this manual before proceeding with the operation of your battery charger. Do not attempt to operate the charger until all required user-assembly is completed.

## Connecting to Batteries Installed in Vehicles

**ATTENTION:** Do not plug the charger power cord into the AC power source or set any of the charger's controls until told to do so in the following instructions.

1. Make sure that the AC power cord is unplugged from the AC outlet and make sure the vehicle's engine is turned off.
2. Position the AC power cord and DC output cables in such a manner that they cannot be damaged by moving engine parts or the vehicle's hood or doors.
3. Check the polarity of the battery terminals. The POSITIVE terminal should be marked POSITIVE, POS, + or P. The NEGATIVE terminal should be marked NEGATIVE, NEG, - or N.
4. Determine whether the vehicle has a positive or negative grounded battery (positive or negative cable is connected to the vehicle's chassis).

**WARNING: Moving engine parts can cause serious injury! Stay clear of fan blades, belts, pulleys and other moving engine parts to reduce risk of serious personal injury.**

- a. Negative Ground Vehicles (most common, see Figure 5)
  - 1) Connect the POS (red, +) clamp from the battery charger to the POS, ungrounded terminal of the battery.
  - 2) Connect the NEG (black, -) clamp from the battery charger to a heavy gauge metal part of the vehicle chassis or engine block away from the battery. DO NOT connect the NEG charger clamp to the NEG battery terminal, carburetor, fuel lines or sheet metal body parts.
- b. Positive Ground Vehicles
  - 1) Connect the NEG (black) charger clamp to the NEG, ungrounded terminal of the battery.
  - 2) Connect the POS (red) charger clamp to a heavy gauge metal part of the vehicle chassis or engine block away from the battery. DO NOT connect the POS (red) charger clamp to the POS battery terminal, carburetor, fuel lines or sheet metal body parts.

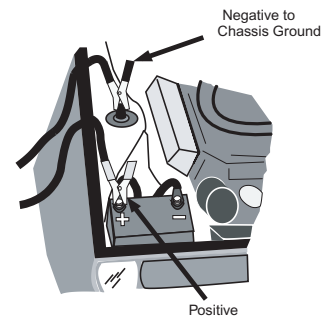

Figure 5. Negative Ground

## Connecting to Batteries Outside a Vehicle

1. Make sure that the AC power cord is unplugged from the AC power source.
2. Check the polarity of the battery terminals (see Figure 6). The POSITIVE terminal should be marked POSITIVE, POS, + or P. The NEGATIVE terminal should be marked NEGATIVE, NEG, - or N.
3. Attach a battery or booster cable, AT LEAST 24 inches long, that is the same (or larger) wire gauge as the charger cable, to the NEGATIVE terminal of the battery.

**WARNING: Battery explosion can injure, and cause property damage! To reduce the risk of battery explosion, NEVER connect both battery charger clamps directly to the two posts of a battery.**

4. Connect the POS (red) charger clamp to the POS battery terminal.

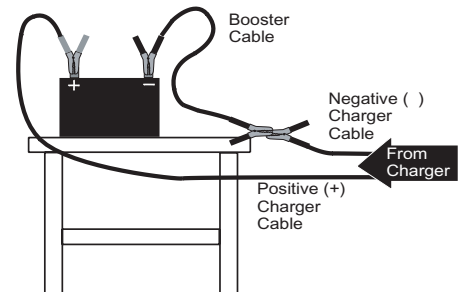

Figure 6. Connecting Outside The Vehicle

5. Position yourself and the free end of the cable (attached to the NEG battery terminal) as far away from the battery as the cable will allow. Then, WHILE FACING AWAY FROM THE BATTERY, connect the NEGATIVE charger clamp to the free end of the cable.

## Charging Instructions

1. Determine the length of time necessary to charge the battery in Charging Time Instructions, but do not start the timer.
2. Set all switches and the timer to OFF and connect the charger power cord into an appropriate AC outlet.
3. Set charging voltage, charging rate and any other functions according to Control Setting Instructions.
4. On models so equipped, set the Timer for the desired length of charge time.

**WARNING: Battery explosion can injure, and cause property damage! To reduce risk of battery explosion, do not overcharge a lead-acid battery. Follow disconnection procedure exactly.**

5. When charging is complete, turn all charger controls to OFF. Then unplug the charger's AC power cord from the AC power source.
6. Disconnect the charger clamp NOT attached directly to the battery first and DO NOT allow the clamp to touch anything. Then, disconnect the charger clamp attached to the battery terminal.

## Reading an Ammeter

The ammeter indicates the charging current being drawn from the charger by the battery. As the battery becomes more fully charged, the charge rate lessens and the ammeter needle moves toward the lower amp numbers on the meter. During engine starting, the ammeter will usually peg to the high-amperage end of the meter.

There is no clear-cut way to read an ammeter and determine exactly when charging is complete. At full charge, the ammeter will still register some current draw (approximately 50% of the charger's output rating). In many cases, overcharging can occur if the charger is not disconnected when the battery reaches full charge – or sooner. Therefore, it is very important that you follow the Charging Time Instructions provided in this manual.

Several battery conditions can also cause the ammeter to appear to indicate a battery near full charge, when in fact, charging has only begun:

**Cold Batteries** (temperatures lower than 32°F or 0°C) will begin charging at a low rate of charge. But as the battery warms up through charging, the charge rate will increase. Then, as the battery charges up, the charge rate will decrease normally.

**WARNING: Battery explosion can injure, and cause property damage! To reduce the risk of battery explosion, check to make sure a cold battery is not frozen. Battery explosion can result from attempting to charge a frozen battery.**

**Sulfated or Deeply-Discharged Lead-Calcium Batteries** require a special activation procedure. See *Pre-Charge Battery Activation, page 14*.

**Shorted Batteries** when the battery being charged has a short circuit, the ammeter will peg at the high-amp end of the scale. If, after 5 to 10 minutes of charging, the needle has not started to move toward lower amperages, unplug the charger and discontinue charging.

If available, use a voltmeter and read the battery voltage. If the voltage is less than 12.0 Volts for a 12 Volt battery or less than 6.0 Volts for a 6 Volt battery, plug the charger back in and resume charging. If, after another 15 to 20 minutes, the ammeter has failed to move toward lower amperages, repeat the voltmeter test. If the voltage has not increased, the battery needs to be serviced or replaced.

**CAUTION:** Do not use ammeter to determine when full charge is reached. Failure to comply with this caution could cause the battery to be damaged from overcharging. The battery could overheat and even explode.



## Charging Time Instructions

Manual battery chargers need to be disconnected from a battery when the battery has reached 100% of charge or sooner. If this is not done, the battery will overcharge, resulting in possible battery damage.

The following instructions or the associated Length of Charge Time Charts (60 amps down to 2 amps, one for each charging range) will allow you to determine how long it will take to bring a specific battery to full charge.

**CAUTION:** Batteries that have 25% charge or less can easily freeze and should be charged at once, but do not charge a battery that is already frozen.

1. Determine the present level of charge in the battery with a hydrometer or electronic percent-of-charge tester.
2. Determine the size of the battery in Amp-Hours or Reserve Capacity. If these ratings are not printed on the battery, contact your local battery dealer for this information. These are the only ratings that can be used to determine length of charging time. Then either use the formula in step 3 or use Table 2 plus Table 3 through Table 9 for the charging rate capabilities of this charger.
3. Use the battery rating, the charge level of the battery, and the amp setting to be used on the charger (see Table 2) in the formula provided below.

$$\left( \frac{\text{Amp Hour Rating of Battery} \times \text{Percent of Charge NEEDED}}{\text{Amp Setting Selected On Charger}} \right) \times 1.25 = \text{Hours to Charge}$$

*Example:*

Battery's Present State of Charge: 25%

Percent of Charge Needed: 100% - 25% = 75% Decimal = .75

Amp Setting on Charger: 10

Amp-Hour Rating of Battery: 60

$\frac{60 \times .75}{10}$	$\times 1.25 = \text{Hours to Reach Full Charge}$
$\frac{45}{10}$	$\times 1.25 = \text{Hours to Reach Full Charge}$
4.5	$\times 1.25 = \text{Hours to Reach Full Charge}$

*Note: If the battery is rated in Reserve Capacity, use the following formula to convert reserve capacity to amp-hours.*

$$\frac{\text{Reserve Capacity}}{2} + 15.5 = \text{Amp-Hour Rating}$$

**Table 2.** Charge Amp Settings

MODEL NUMBER	6V HIGH	12V LOW	12V MED.	12V HIGH	24V HIGH	START
OS6110		2 Amp	15 Amp	40 Amp		200 Amp 12V
OS6120	40 Amp	2 Amp	15 Amp	40 Amp		200 Amp 12V 130 Amp 6V
OS6130	60 Amp	2 Amp	40 Amp	60 Amp		250 Amp 12V 185 Amp 6V
OS6150	60 Amp		40 Amp	60 Amp	30 Amp	225 Amp 12V 160 Amp 6V
OS6140	0 —60 Amps					250 Amp 12V 185 Amp 6V

**Table 3.** Length of Charge Time Chart 60 Amps

BATTERY RATINGS				MINUTES TO CHARGE @ 60 AMPS for the percent-of-charge now in the battery				
Approx. Marine Cranking Amps	Approx. Cold Cranking Amps	Ampere Hours	Reserve Capacity (Minutes)	0%	25%	50%	75%	100%
600	750	66	100	83	62	41	21	0.0
		61	90	76	57	38	19	0.0
500	550	56	80	70	53	35	18	0.0
		51	70	64	48	32	16	0.0
400	400	46	60	58	43	29	14	0.0
		41	50	51	38	26	13	0.0
300	300	36	40	45	34	23	11	0.0
		31	30	39	29	19	10	0.0
	200	26	20	33	24	16	8	0.0

**Table 4.** Length of Charge Time Chart 40 Amps

BATTERY RATINGS				MINUTES TO CHARGE @ 40 AMPS for the percent-of-charge now in the battery				
Approx. Marine Cranking Amps	Approx. Cold Cranking Amps	Ampere Hours	Reserve Capacity (Minutes)	0%	25%	50%	75%	100%
600	750	66	100	124	93	62	31	0.0
		61	90	114	86	57	29	0.0
500	550	56	80	105	79	53	26	0.0
		51	70	96	72	48	24	0.0
400	400	46	60	86	65	43	22	0.0
		41	50	77	58	38	19	0.0
300	300	36	40	68	51	34	17	0.0
		31	30	58	44	29	15	0.0
	200	26	20	49	37	24	12	0.0

**Table 5.** Length of Charge Time Chart 15 Amps

BATTERY RATINGS				HOURS TO CHARGE @ 15 AMPS for the percent-of-charge now in the battery				
Approx. Marine Cranking Amps	Approx. Cold Cranking Amps	Ampere Hours	Reserve Capacity (Minutes)	0%	25%	50%	75%	100%
600	750	66	100	5.5	4.1	2.8	1.4	0.0
		61	90	5.1	3.8	2.6	1.3	0.0
500	550	56	80	4.7	3.5	2.3	1.2	0.0
		51	70	4.3	3.2	2.2	1.1	0.0
400	400	46	60	3.8	2.9	1.9	1.0	0.0
		41	50	3.4	2.6	1.7	0.9	0.0
300	300	36	40	3.0	2.3	1.5	0.8	0.0
		31	30	2.6	2.0	1.3	0.7	0.0
	200	26	20	2.2	1.7	1.1	0.6	0.0
DEEP CYCLE*				HOURS TO CHARGE				
N/A	N/A	135	N/A	11.2	8.4	5.6	2.8	0.0
N/A	N/A	110	N/A	9.2	6.9	4.5	2.3	0.0
N/A	N/A	100	N/A	8.4	6.3	4.1	2.1	0.0
N/A	N/A	90	N/A	7.4	5.6	3.7	1.9	0.0
N/A	N/A	80	N/A	6.7	5.1	3.3	1.7	0.0

**Table 6.** Length of Charge Time Chart 2 Amps

BATTERY RATINGS				HOURS TO CHARGE @ 2 AMPS for the percent-of-charge now in the battery				
Approx. Marine Cranking Amps	Approx. Cold Cranking Amps	Ampere Hours	Reserve Capacity (Minutes)	0%	25%	50%	75%	100%
600	750	66	100	41.3	30.9	20.6	10.3	0.0
		61	90	38.1	28.6	19.1	9.5	0.0
500	550	56	80	35.0	26.3	17.5	8.8	0.0
		51	70	31.9	23.9	15.9	8.0	0.0
400	400	46	60	28.8	21.6	14.4	7.2	0.0
		41	50	25.6	19.2	12.8	6.4	0.0
300	300	36	40	22.5	16.9	11.3	5.6	0.0
		31	30	19.4	14.5	9.7	4.8	0.0
	200	26	20	16.3	12.2	8.1	4.1	0.0
DEEP CYCLE*				HOURS TO CHARGE				
N/A	N/A	135	N/A	84.4	63.3	42.2	21.1	0.0
N/A	N/A	110	N/A	68.8	51.6	34.4	17.2	0.0
N/A	N/A	100	N/A	62.5	46.9	31.3	15.6	0.0
N/A	N/A	90	N/A	56.3	42.2	28.1	14.1	0.0
N/A	N/A	80	N/A	50.0	37.5	25.0	12.5	0.0

*Note: The length of charge times on these charts are very accurate when using the Reserve Capacity or Ampere Hour battery ratings. The Cold Cranking Amps and Marine Cranking Amps ratings are approximations and vary from battery to battery. Always follow the battery manufacturer's specific charging instructions.*

Do not charge deep cycle batteries with a battery charger, or setting on a charger, that has a rating of more than 20 amps. Follow the battery manufacturer's specific charging instructions.

## Engine Starting

This battery charger can provide a high-current output to help start a vehicle with a weak battery. However, the onboard computer in some vehicles can be damaged when attempting to jumpstart. ALWAYS READ THE VEHICLE OPERATOR'S MANUAL BEFORE AUXILIARY STARTING to determine if jumpstarting can do damage to the vehicle. If not, read and follow these instructions.

**CAUTION:** Do not try to boost start a vehicle that does not contain a battery or you may damage electrical systems in the vehicle.

1. Connect the battery charger to the vehicle according to Operating Instructions.
2. Charge the battery for 5 to 10 minutes at the appropriate charge rate for the size of battery.
3. Set the Rate Selector to START and try to start the vehicle. If the vehicle doesn't start after 3 to 4 seconds, stop and wait 3 to 4 minutes. Repeat until engine starts.

**CAUTION:** Excessive continuous engine cranking can damage vehicle starter motors.

*Note: If the engine spins but fails to start after several starting attempts, there is an engine problem not related to the starting system. Discontinue cranking the engine until the other problem is found and corrected.*

*This battery charger has an internal thermal protector to prevent overheating and damage to the battery charger. If, after repeated starting attempts, the ammeter registers zero output, wait 3 to 4 minutes for the charger to cool. The thermal protector will automatically reset and allow you to continue.*

# MAINTENANCE

**CAUTION:** Make sure charger is unplugged from AC outlet before performing any cleaning or maintenance.

A minimum amount of care can keep your battery charger working and looking good for years.

1. Clean the clamps after each use. Wipe off any battery fluid that may have come in contact with the clamps to prevent corrosion. Battery fluid may be neutralized with a solution of water and baking soda.
2. Coil the input and output cables neatly after each use. This will help prevent damage to the cables and the charger.
3. If needed, the case may be wiped clean with a soft cloth.

# TROUBLESHOOTING

***No ammeter reading (battery does not accept charge).***

1. Make sure charger is plugged into live AC outlet.
2. After unplugging unit, check connection at battery. Make sure the clamps are making good contact with the battery terminal (or vehicle chassis).
3. Check to see that the battery is capable of being charged – it may be damaged or sulfated.
4. Make sure that you have selected the proper charge voltage for the battery being charged.
5. Make sure you are allowing enough time for charging the battery. Refer to the charging time formulas earlier in this manual.

***Ammeter shows reading, but battery does not accept charge.***

1. Check to see that the battery is capable of being charged – it may be damaged or sulfated.
2. Make sure you are allowing enough time for charging the battery. Refer to the charging time formulas earlier in this manual.

***Vehicle will not start in engine start mode.***

1. Unplug charger and check connections as described above.
2. Determine if charger is charging; if meter indicates any amperage, charger is working; if no amperage is indicated, wait several minutes and recheck. Charger thermal protector may have tripped.
3. If engine turns over but does not start, problem is with vehicle, not charger. Service vehicle.

See Limited Warranty for further information on obtaining service.