



Safety glasses should be worn at all times while installing this product.

YEARS: 2016

MAKE: NISSAN

MODEL: TITAN XD

STYLE: TRUCK

WARNING: NEVER EXCEED YOUR VEHICLE MANUFACTURER'S RECOMMENDED TOWING CAPACITY

WEIGHT CARRYING:
 TRAILER WEIGHT: 5000 LBS.
 TONGUE WEIGHT: 500 LBS.

**GROSS LOAD CAPACITY WHEN USED AS A STRAIGHT LINE PULL:
 9,000 LBS MAX.**

PRO INSTALL TIME: 20 MIN.
NOVICE INSTALL TIME: 40 MIN.

IF YOU ARE HESITANT TO UNDERTAKE THIS TASK ON YOUR OWN, CONTACT AN AUTHORIZED CURT INSTALLER FOR ADDITIONAL ASSISTANCE.

INSTALLATION TIPS:

- BEFORE YOU BEGIN INSTALLATION, READ ALL INSTRUCTIONS THOROUGHLY.
- TO EASE INSTALLATION, 2 PEOPLE MAY BE REQUIRED.
- USING PROPER TOOLS WILL GREATLY IMPROVE THE QUALITY OF THE INSTALL AND REDUCE THE TIME REQUIRED.



INSTALLATION REQUIRES:

 17mm 19mm SOCKET	 9" SOCKET EXTENSION	 RATCHET
 TORQUE WRENCH	 19mm SOCKET TORQUE ADAPTER	 SAFETY GLASSES

LEVEL OF DIFFICULTY: EASY

EASY	MODERATE	CHALLENGING
	WELDNUT CLEANING MAY BE REQUIRED	
	NO DRILLING REQUIRED	

HITCH ILLUSTRATION:

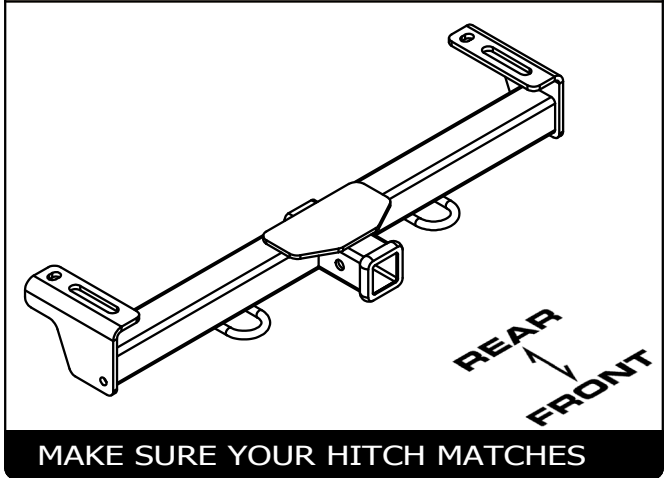

PERIODICALLY CHECK THIS RECEIVER HITCH TO ENSURE ALL FASTENERS ARE TIGHT AND ALL STRUCTURAL COMPONENTS ARE SOUND
 CURT Manufacturing LLC. warrants this product to be free of defects in material and/or workmanship at the time of retail purchase by the original purchaser. If the product is found to be defective, CURT Manufacturing LLC. may repair or replace the product at their option, when the product is returned, prepaid, with proof of purchase. Alteration to, misuse of, or improper installation of this product voids the warranty. CURT Manufacturing LLC.'s liability is limited to repair or replacement of products found to be defective, and specifically excludes liability for incidental or consequential loss or damage.

INSTALLATION WALKTHROUGH:

Parts List			
ITEM	QTY	PART NUMBER	DESCRIPTION
1	4	M12 - 1.75 x 50mm	HEX BOLT
2	4	9/16" CONICAL WASHER	CONICAL TOOTHED WASHER
3	2	9_16 WASHER USS FLAT	FLAT WASHER
4	4	CM-SP52	.500 x 1.25 x 2.50" ROUND HOLE SPACER

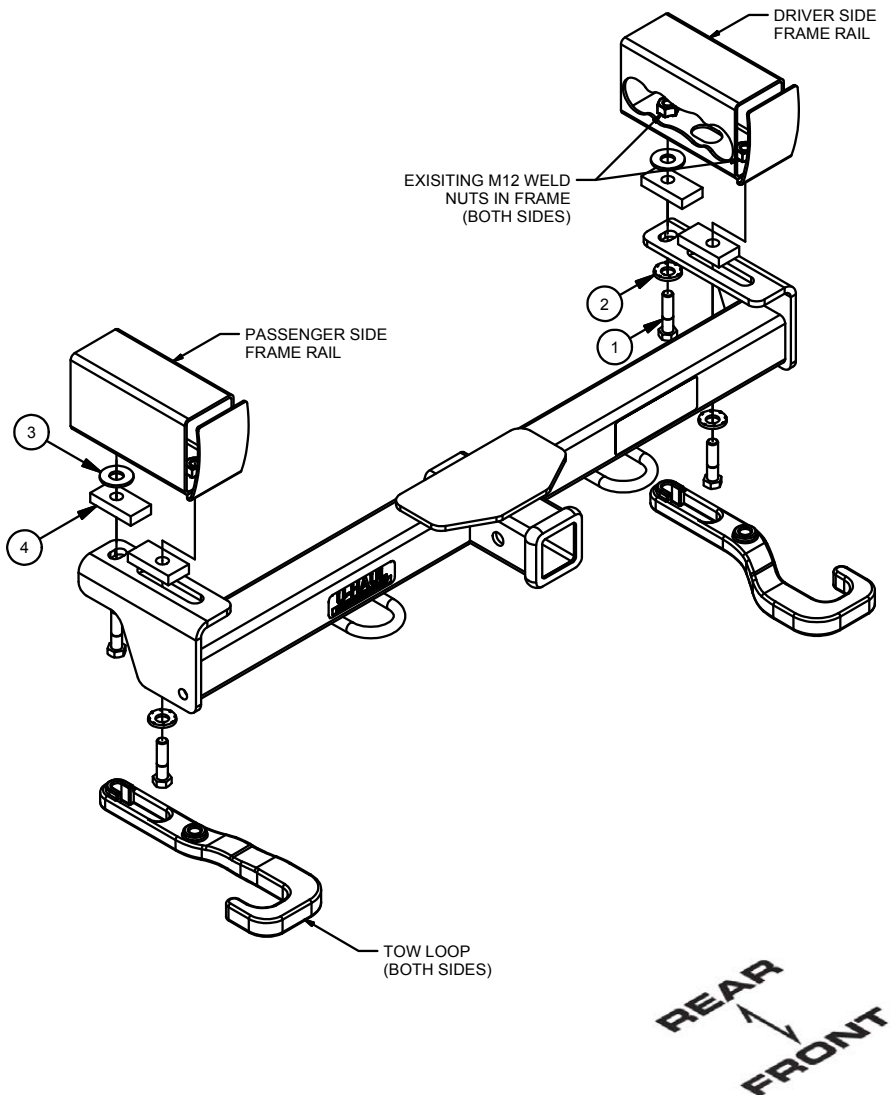

1. Remove two (2) hex bolts and one (1) tow loop from bottom of each frame rail and return to vehicle owner. These will be replaced with the included M12 hardware.

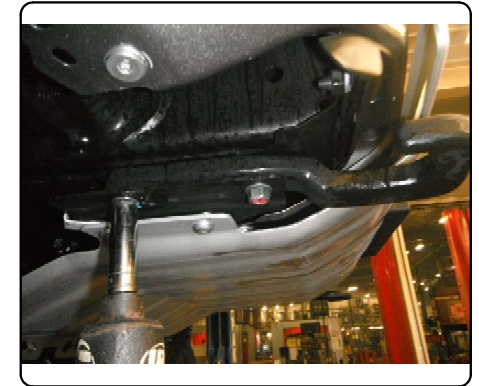
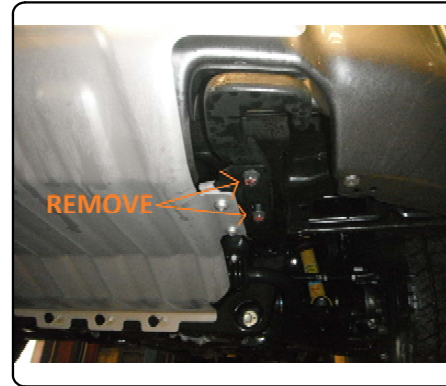

2. Insert one (1) hex bolt, one (1) 9/16" conical toothed washer and one (1) CM-SP52 through rear end of each side plate slot. Slide hitch in over tow loop plate. Loosely insert hex bolt into forward most weldnut in each frame.



INSTALLATION WALKTHROUGH:

3. Slide hitch rearward into position. Place one (1) 9/16" flat washer on top of one (1) CM-SP52 and set on top of each side plate aligned with rear most hole.



4. Insert one (1) M12 hex bolt with one (1) 9/16" conical toothed washer through side plate, CM-SP52 spacer and 9/16" flat washer into each rear most weldnut.

CONICAL TOOTHED WASHER ORIENTATION DIAGRAM

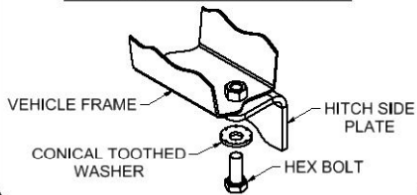

5. Secure all M12 fasteners with socket wrench. A 19mm end wrench may be used to secure forward most bolt.



6. Torque all M12 fasteners to 86 ft-lbs. Use a 19mm socket torque adapter to torque front bolts.



31077 NISSAN TITAN XD

*****DO NOT EXCEED VEHICLE MANUFACTURER'S RECOMMENDED TOWING CAPACITY ***.**

FRONT MOUNTED ACCESSORIES

1) Do not exceed front axle Gross Weight Rating (GAWR). Consult owners manual or specification plate located on driver's door frame. Measure gross front axle weight by placing front wheels of loaded vehicle on a scale.

WARNING: Exceeding GAWR may overload the front axle and/or suspension. This could result in **accident, property damage and personal injury.**

- 2) Reposition front mounted license plate if obstructed.
- 3) Do not obstruct vehicle lights.
- 4) Allow free air flow into grille opening.
- 5) Rear wheel traction may be reduced. This could effect handling. Reduce speed and drive with caution.
- 6) Accessories extend front of vehicle. This may reduce approach angle. Use caution when parking and maneuvering.
- 7) Do not obstruct driver view.

VEHICLE RECOVERY AND WINCHING TIPS

1) Use OEM tow hooks, recovery eyes or a clevis mount for attachment of a tow strap or winch cable.

WARNING: NEVER use a ball and/or ball mount as an anchor point for tow strap or winch cable. Severe personal injury or death could result.

- 2) Observe winch manufacturer's recommendations, cautions and warnings.
- 3) Attach return cable to tow hook or recovery eye when using a snatch block (See figure 1).

CAUTION: Do not attach return cable to winch mount. This may overload winch mount and/or front mounted receiver.

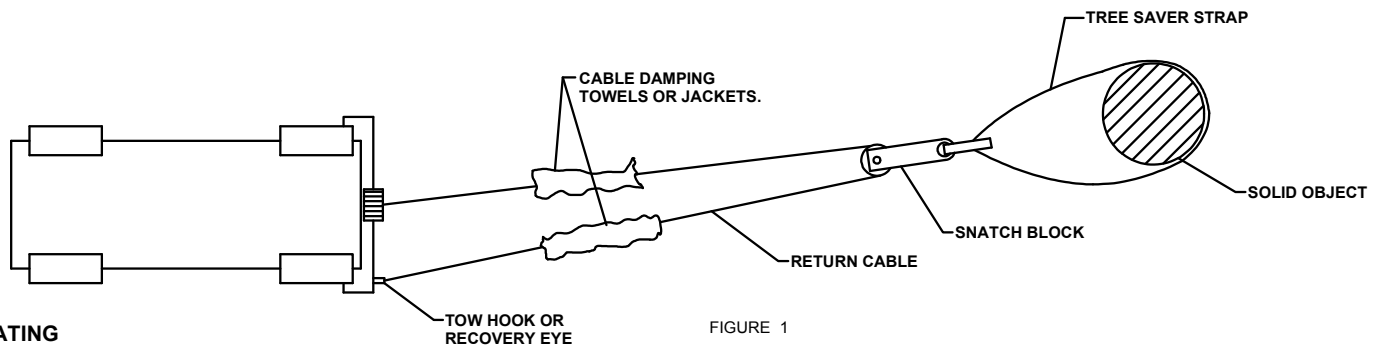

RATING

For **Maximum** line pull rating, winch cable must not exceed:
- 15 degree angle up or down from horizontal (See Figure 2).
- 45 degree angle left or right from straight ahead (See Figure 3).

CAUTION: Exceeding the maximum line pull rating may over load winch, winch mount, and/or front mounted receiver.

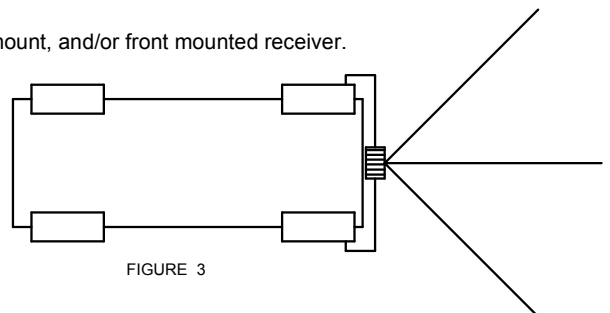
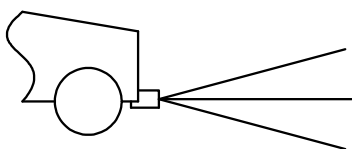

31077

NISSAN TITAN XD

GROSS LOAD CAPACITY WHEN USED AS A WEIGHT CARRYING HITCH: 5,000 LBS. TRAILER WEIGHT & 500 LBS. TONGUE WEIGHT.



GROSS LOAD CAPACITY WHEN USED AS A STRAIGHT LINE PULL: 9,000 LBS. MAX. LINE PULL.

WARNING: * DO NOT EXCEED VEHICLE MANUFACTURER'S RECOMMENDED TOWING CAPACITY. *****

Parts List			
ITEM	QTY	PART NUMBER	DESCRIPTION
1	4	M12 - 1.75 x 50mm	HEX BOLT
2	4	9/16" CONICAL WASHER	CONICAL TOOTHED WASHER
3	2	9_16 WASHER USS FLAT	FLAT WASHER
4	4	CM-SP52	.500 x 1.25 x 2.50" ROUND HOLE SPACER

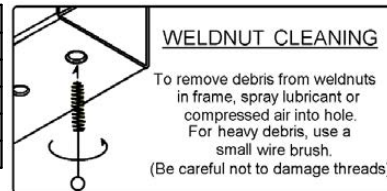

TOOLS REQUIRED	
17mm/19mm SOCKET	
9" EXTENSION	
RATCHET	
19mm SOCKET TORQUE ADAPTER	
TORQUE WRENCH	
SAFETY GLASSES	

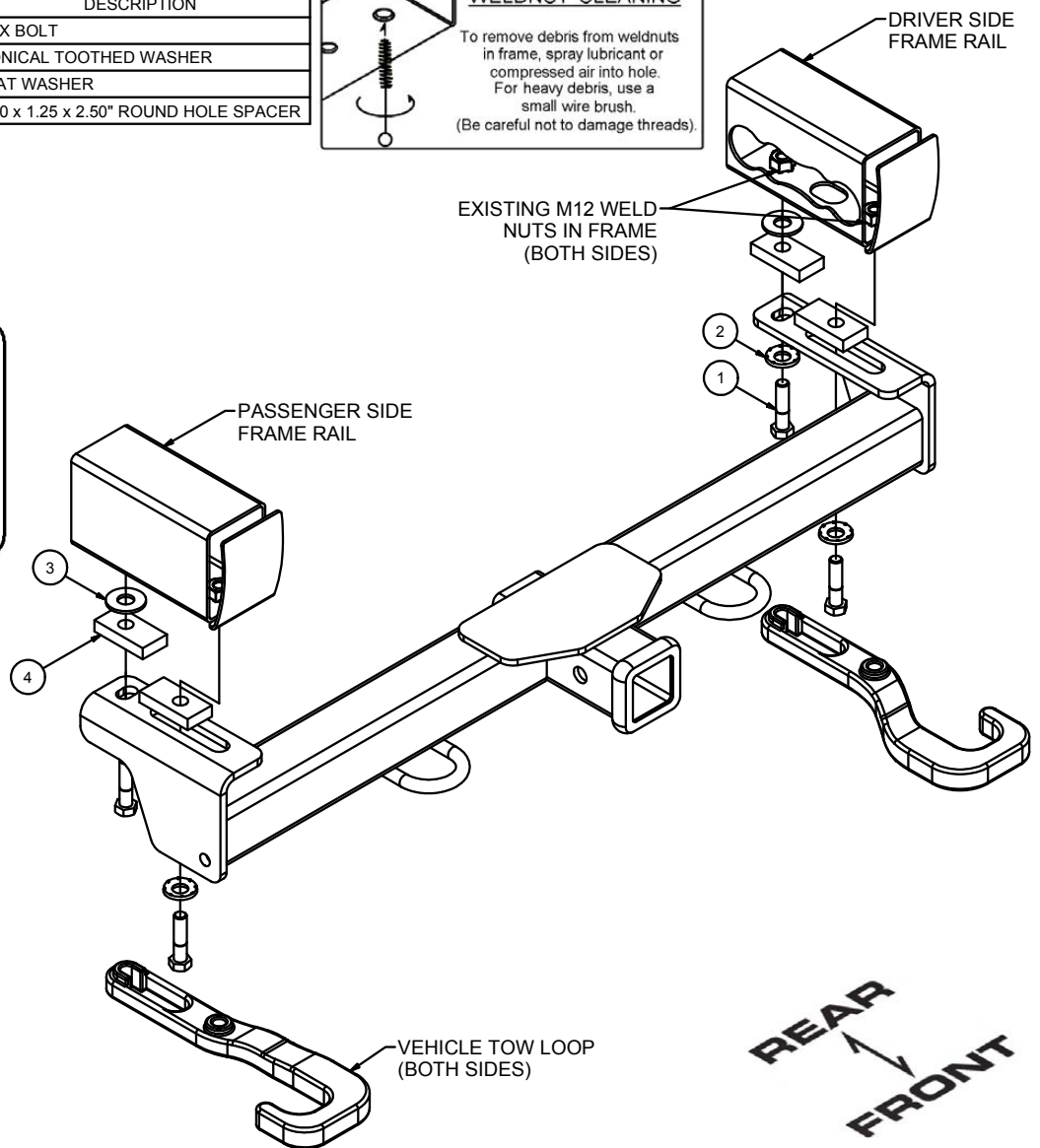
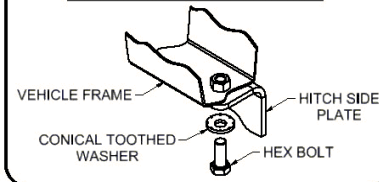
CONICAL TOOTHED WASHER ORIENTATION DIAGRAM

HITCH WEIGHT: 29 LBS.

INSTALL TIME

PROFESSIONAL: 20 MINUTES

NOVICE (DIY): 45 MINUTES

INSTALL NOTES:

- NO DRILLING REQUIRED
- WELDNUT CLEANING

INSTALLATION STEPS

1. Remove two (2) hex bolts attaching tow loop and one (1) tow loop from bottom of each frame rail and return to vehicle owner. These will be replaced with the included M12 hardware.
2. Insert one (1) hex bolt, one (1) 9/16" conical toothed washer and one (1) CM-SP52 through rear end of large slot in each side plate. Slide hitch in over tow loop plate. Loosely insert hex bolt into forward most weldnut in each frame.
3. Slide hitch rearward into position. Place one (1) 9/16" flat washer on top of one (1) CM-SP52 and set on top of each side plate, aligned with rear most hole.
4. Insert one (1) M12 hex bolt with one (1) 9/16" conical toothed washer through side plate, CM-SP52 spacer and 9/16" flat washer into each rear most weldnut.
5. Secure all M12 fasteners with socket wrench. A 19mm end wrench may be used to secure forward most bolt.
6. Torque all M12 fasteners to 86 ft-lbs. Use a 19mm socket torque adapter to torque front bolts.

PERIODICALLY CHECK THIS RECEIVER HITCH TO ENSURE THAT ALL FASTENERS ARE TIGHT AND THAT ALL STRUCTURAL COMPONENTS ARE SOUND.

CURT Manufacturing LLC., warrants this product to be free of defects in material and/or workmanship at the time of retail purchase by the original purchaser. If the product is found to be defective, CURT Manufacturing LLC., may repair or replace the product, at their option, when the product is returned, prepaid, with proof of purchase. Alteration to, misuse of, or improper installation of this product voids the warranty. CURT Manufacturing LLC.'s liability is limited to repair or replacement of products found to be defective, and specifically excludes liability for incidental or consequential loss or damage. This product complies with safety specifications and requirements for connecting devices and towing systems of the state of New York, V.E.S.C.Regulation V-5 and SAE J684.

31077 NISSAN TITAN XD

*****DO NOT EXCEED VEHICLE MANUFACTURER'S RECOMMENDED TOWING CAPACITY***.**

FRONT MOUNTED ACCESSORIES

1) Do not exceed front axle Gross Weight Rating (GAWR). Consult owners manual or specification plate located on driver's door frame. Measure gross front axle weight by placing front wheels of loaded vehicle on a scale.

WARNING: Exceeding GAWR may overload the front axle and/or suspension. This could result in **accident, property damage and personal injury.**

- 2) Reposition front mounted license plate if obstructed.
- 3) Do not obstruct vehicle lights.
- 4) Allow free air flow into grille opening.
- 5) Rear wheel traction may be reduced. This could effect handling. Reduce speed and drive with caution.
- 6) Accessories extend front of vehicle. This may reduce approach angle. Use caution when parking and maneuvering.
- 7) Do not obstruct driver view.

VEHICLE RECOVERY AND WINCHING TIPS

1) Use OEM tow hooks, recovery eyes or a clevis mount for attachment of a tow strap or winch cable.

WARNING: NEVER use a ball and/or ball mount as an anchor point for tow strap or winch cable. Severe personal injury or death could result.

- 2) Observe winch manufacturer's recommendations, cautions and warnings.
- 3) Attach return cable to tow hook or recovery eye when using a snatch block (See figure 1).

CAUTION: Do not attach return cable to winch mount. This may overload winch mount and/or front mounted receiver.

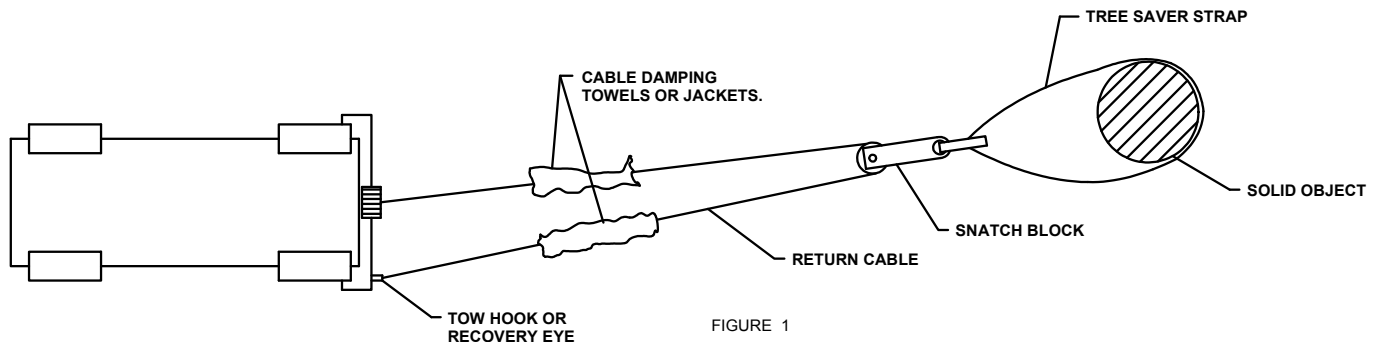

RATING

For **Maximum** line pull rating, winch cable must not exceed:
- 15 degree angle up or down from horizontal (See Figure 2).
- 45 degree angle left or right from straight ahead (See Figure 3).

CAUTION: Exceeding the maximum line pull rating may over load winch, winch mount, and/or front mounted receiver.

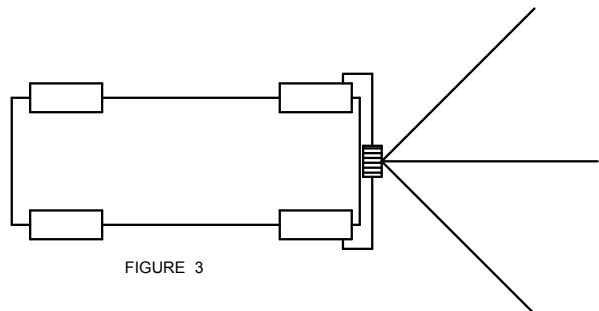
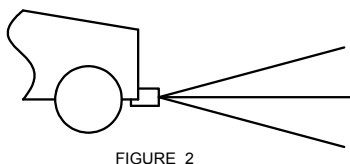

CURT Manufacturing LLC., warrants this product to be free of defects in material and/or workmanship at the time of retail purchase by the original purchaser. If the product is found to be defective, CURT Manufacturing LLC., may repair or replace the product, at their option, when the product is returned, prepaid, with proof of purchase. Alteration to, misuse of, or improper installation of this product voids the warranty. CURT Manufacturing LLC.'s liability is limited to repair or replacement of products found to be defective, and specifically excludes liability for incidental or consequential loss or damage.

Accept no compromises, choose only quality trailer hitches and towing.