

# 1984 - 2001 JEEP CHEROKEE, COMANCHE, & WAGONEER

EXCLUDING GRAND WAGONEER

GROSS LOAD CAPACITY WHEN USED AS A WEIGHT CARRYING HITCH: 3,000 LBS. TRAILER WEIGHT & 300 LBS. TONGUE WEIGHT.

GROSS LOAD CAPACITY WHEN USED AS A STRAIGHT LINE PULL: 9,000 LBS. MAX. LINE PULL.

\*\*\* DO NOT EXCEED VEHICLE MANUFACTURER'S RECOMMENDED TOWING CAPACITY. \*\*\*

Parts List			
ITEM	QTY	PART NUMBER	DESCRIPTION
1	2	1_2 FISHWIRE	1/2" FISHWIRE
2	2	HFN 1213	HEX FLANGE NUT
3	4	M10 - 1.5 x 35mm	HEX TAP BOLT
4	4	3/8"	CONICAL TOOTHED WASHER
5	2	1/2 - 13 x 2 1/4	CARRIAGE BOLT
6	2	CM-SP1	.250 x 1.50 x 2.00" SQUARE HOLE SPACER
7	2	CM-SP52	.500 x 1.25 x 2.50" ROUND HOLE SPACER

**FISHWIRE TECHNIQUE**  
 INSERT COILED END OF FISHWIRE TOOL THROUGH HITCH MOUNTING HOLE IN VEHICLE FRAME RAIL AND OUT THE ACCESS HOLE. PASS COILED END OF FISHWIRE THROUGH SPACER AND THREAD BOLT INTO COIL. KINK WIRE TO KEEP SPACER SEPARATE FROM BOLT AS SHOWN. PULL FISHWIRE, SPACER, AND BOLT THROUGH FRAME AND OUT MOUNTING HOLE. USE FISHWIRE TO GUIDE HITCH DURING MOUNTING AND PREVENT LOSS OF BOLT / SPACER INSIDE FRAME RAIL.  
 \*\*NOTE: SOME VEHICLES MAY FISHWIRE THROUGH END OF FRAME\*\*

**WELDNUT CLEANING**  
 To remove debris from weldnuts in frame, spray lubricant or compressed air into hole. For heavy debris, use a small wire brush. (Be careful not to damage threads).

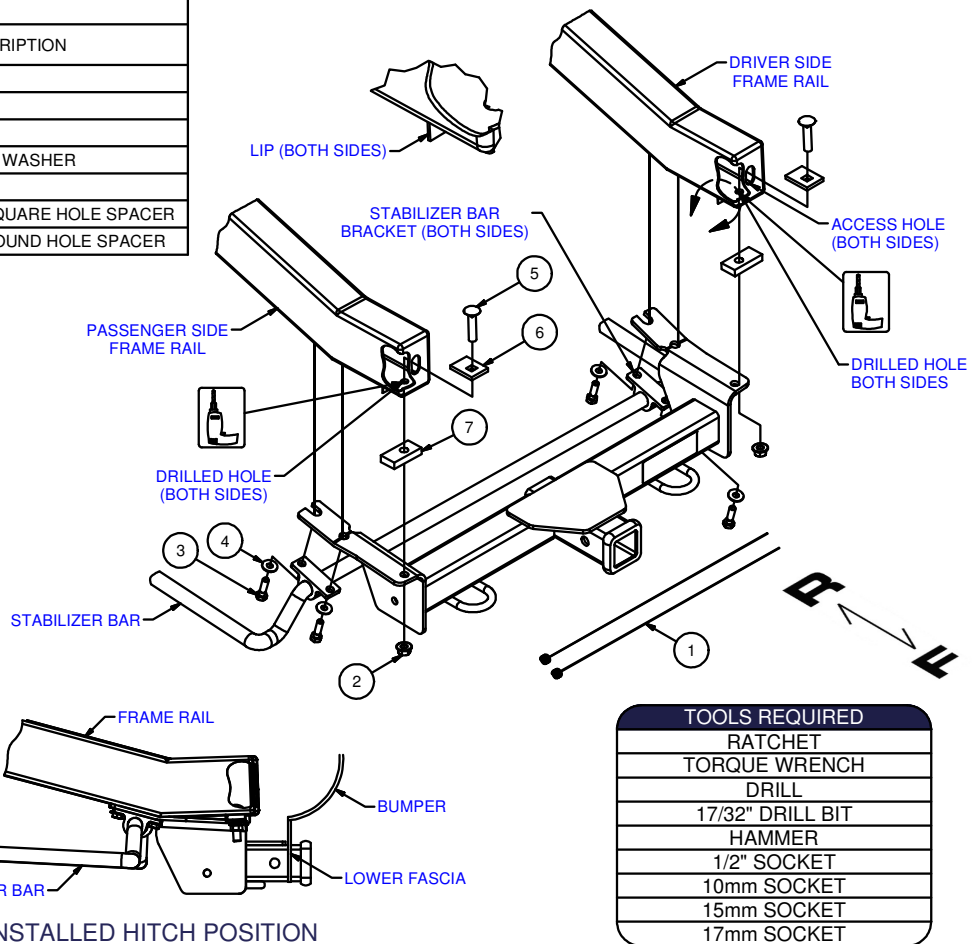

TOOLS REQUIRED
RATCHET
TORQUE WRENCH
DRILL
17/32" DRILL BIT
HAMMER
1/2" SOCKET
10mm SOCKET
15mm SOCKET
17mm SOCKET

HITCH WEIGHT: 29 LBS.  
 INSTALL TIME: 30 MINUTES  
 INSTALL NOTES:  
 -SKID SHIELD REMOVAL  
 -FASCIA TRIMMING  
 -DRILLING REQUIRED

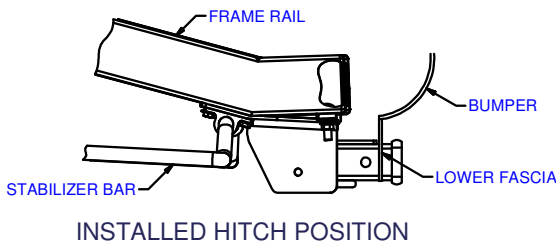

## INSTALLATION STEPS

1. If present, remove skid shield and return to vehicle owner.
2. Remove or trim lower fascia to clear hitch. CONSULT VEHICLE OWNER.
3. Remove stabilizer bar fasteners and brackets allowing stabilizer bar to swing free. Return fasteners to owner.
4. Raise hitch, stabilizer bar, and stabilizer bar brackets into position. **NOTE:** The lip on the underside of the frame rails may need to be flattened so SP52 spacers can be installed in step (7).
5. Install 10mm hex bolts and 3/8" conical toothed washers through the stabilizer bar brackets, hitch side plates, and into existing weldnuts as shown.
6. Using hitch as a template drill 17/32" holes into driver and passenger side frame rails as shown.
7. Position SP52 spacers between the frame rails and side plates as shown.
8. Fishwire 1/2" carriage bolts and SP1 spacers through the access holes in frame and out the holes drilled in step (6).
9. Remove fishwires and secure with 1/2" flange nuts.
10. Torque all 1/2" hardware to 110 ft-lbs and 10mm hardware to 48 ft-lbs.

**PERIODICALLY CHECK THIS RECEIVER HITCH TO ENSURE THAT ALL FASTENERS ARE TIGHT AND THAT ALL STRUCTURAL COMPONENTS ARE SOUND.**

# 1984 - 2001 JEEP CHEROKEE, COMANCHE, & WAGONEER

\*\*\*DO NOT EXCEED VEHICLE MANUFACTURER'S RECOMMENDED TOWING CAPACITY\*\*\*.

## FRONT MOUNTED ACCESSORIES

1) Do not exceed front axle Gross Weight Rating (GAWR). Consult owners manual or specification plate located on driver's door frame. Measure gross front axle weight by placing front wheels of loaded vehicle on a scale.

**WARNING:** Exceeding GAWR may overload the front axle and/or suspension. This could result in **accident, property damage and personal injury.**

- 2) Reposition front mounted license plate if obstructed.
- 3) Do not obstruct vehicle lights.
- 4) Allow free air flow into grille opening.
- 5) Rear wheel traction may be reduced. This could effect handling. Reduce speed and drive with caution.
- 6) Accessories extend front of vehicle. This may reduce approach angle. Use caution when parking and maneuvering.
- 7) Do not obstruct driver view.

## VEHICLE RECOVERY AND WINCHING TIPS

1) Use OEM tow hooks, recovery eyes or a clevis mount for attachment of a tow strap or winch cable.

**WARNING: NEVER** use a ball and/or ball mount as an anchor point for tow strap or winch cable. Severe personal injury or death could result.

- 2) Observe winch manufacturer's recommendations, cautions and warnings.
- 3) Attach return cable to tow hook or recovery eye when using a snatch block (See figure 1).

**CAUTION:** Do not attach return cable to winch mount. This may overload winch mount and/or front mounted receiver.

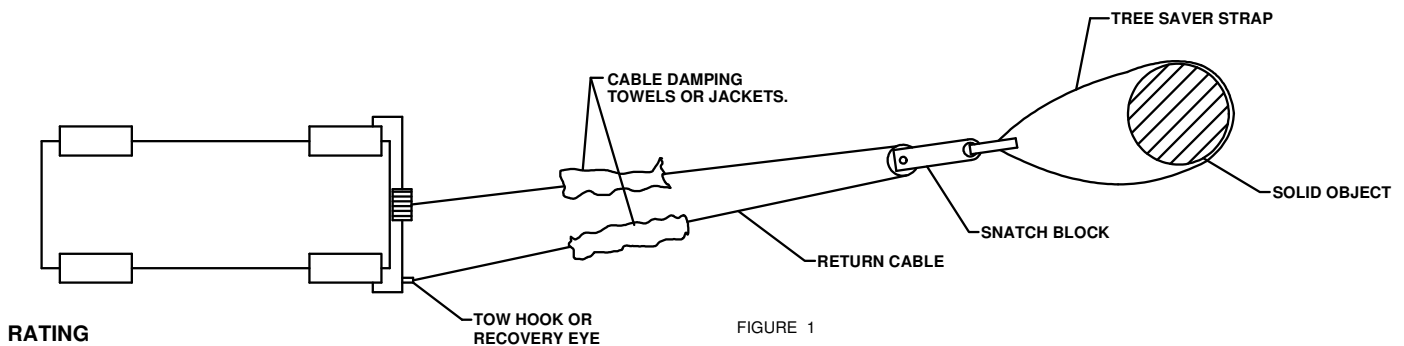

## RATING

For **Maximum** line pull rating, winch cable must not exceed:  
- 15 degree angle up or down from horizontal (See Figure 2).  
- 45 degree angle left or right from straight ahead (See Figure 3).

**CAUTION:** Exceeding the maximum line pull rating may over load winch, winch mount, and/or front mounted receiver.

