

FORD F-150 AND F-250 4WD LD, EXPEDITION

GROSS LOAD CAPACITY WHEN USED AS A WEIGHT CARRYING HITCH: 5,000 LBS. TRAILER WEIGHT & 500 LBS. TONGUE WEIGHT.
 GROSS LOAD CAPACITY WHEN USED AS A STRAIGHT LINE PULL: 9,000 LBS. MAX. LINE PULL.
 *** DO NOT EXCEED VEHICLE MANUFACTURER'S RECOMMENDED TOWING CAPACITY. ***

Parts List			
ITEM	QTY	PART NUMBER	DESCRIPTION
1	1	CM-375-FW	FISHWIRE TOOL
2	2	3/8 - 16 x 1 3/4	CARRIAGE BOLT
3	2	3/8-16	HEX FLANGE NUT
4	2	CM-SP18	.250 x 1.00 x 2.00" SQUARE HOLE SPACER

TOOLS REQUIRED
RATCHET
TORQUE WRENCH
6" EXTENSION
9/16" SOCKET
10mm SOCKET (DEEP)
15mm SOCKET
"FLAT" SCREW DRIVER
PAINT MARKER
TAPE MEASURE
TIN SNIPS / GRINDER

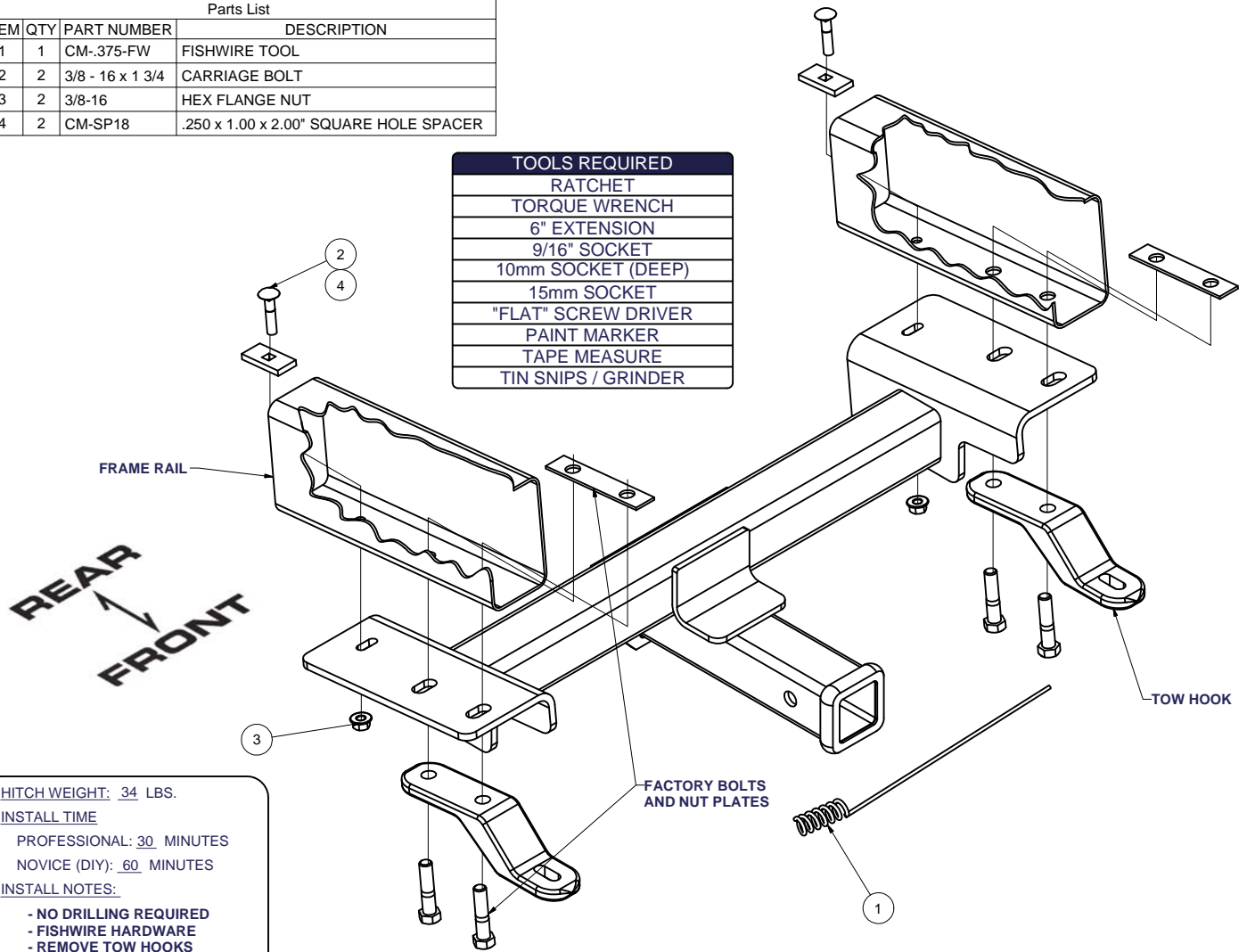

HITCH WEIGHT: 34 LBS.
 INSTALL TIME
 PROFESSIONAL: 30 MINUTES
 NOVICE (DIY): 60 MINUTES
 INSTALL NOTES:
 - NO DRILLING REQUIRED
 - FISHWIRE HARDWARE
 - REMOVE TOW HOOKS
 - TRIM SKID SHIELD

INSTALLATION STEPS

** skid plate may need to be notched or removed on some models. **

1. Remove the factory tow hooks and set them aside with the bolts. Leave the existing nut plates inside the frame for final hitch installation.
2. Fishwire the 3/8" carriage bolts and spacers through the frame as shown.
3. Fasten the hitch to the frame using 3/8" flange nuts.
4. Reinstall the factory tow hooks by passing the factory supplied bolts thru the hook and hitch and then into the nut plates.
5. Torque fasteners 3/8" to 45 lb-ft. , 7/16" to 70 lb-ft. , 1/2" to 110 lb-ft. , 5/8" to 210 lb-ft.

PERIODICALLY CHECK THIS RECEIVER HITCH TO ENSURE THAT ALL FASTENERS ARE TIGHT AND THAT ALL STRUCTURAL COMPONENTS ARE SOUND.

FORD F-150 AND F-250 4WD LD, EXPEDITION

*****DO NOT EXCEED VEHICLE MANUFACTURER'S RECOMMENDED TOWING CAPACITY ***.**

FRONT MOUNTED ACCESSORIES

1) Do not exceed front axle Gross Weight Rating (GAWR). Consult owners manual or specification plate located on driver's door frame. Measure gross front axle weight by placing front wheels of loaded vehicle on a scale.

WARNING: Exceeding GAWR may overload the front axle and/or suspension. This could result in **accident, property damage and personal injury.**

- 2) Reposition front mounted license plate if obstructed.
- 3) Do not obstruct vehicle lights.
- 4) Allow free air flow into grille opening.
- 5) Rear wheel traction may be reduced. This could effect handling. Reduce speed and drive with caution.
- 6) Accessories extend front of vehicle. This may reduce approach angle. Use caution when parking and maneuvering.
- 7) Do not obstruct driver view.

VEHICLE RECOVERY AND WINCHING TIPS

1) Use OEM tow hooks, recovery eyes or a clevis mount for attachment of a tow strap or winch cable.

WARNING: NEVER use a ball and/or ball mount as an anchor point for tow strap or winch cable. Severe personal injury or death could result.

- 2) Observe winch manufacturer's recommendations, cautions and warnings.
- 3) Attach return cable to tow hook or recovery eye when using a snatch block (See figure 1).

CAUTION: Do not attach return cable to winch mount. This may overload winch mount and/or front mounted receiver.

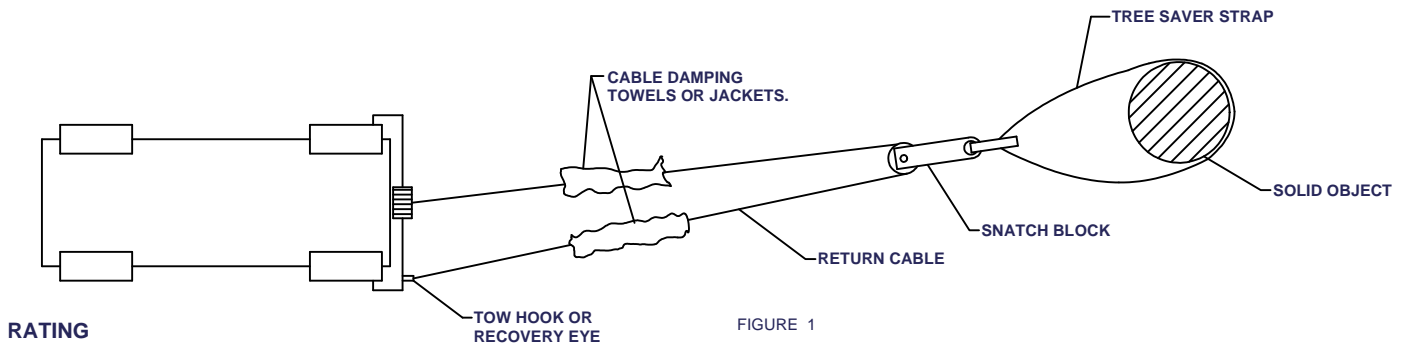

RATING

For **Maximum** line pull rating, winch cable must not exceed:
- 15 degree angle up or down from horizontal (See Figure 2).
- 45 degree angle left or right from straight ahead (See Figure 3).

CAUTION: Exceeding the maximum line pull rating may over load winch, winch mount, and/or front mounted receiver.

