



Safety glasses should be worn at all times while installing this product.

YEARS: 2015

MAKE: CHEVROLET, GMC

MODEL: TAHOE, YUKON

STYLE: SUV

WARNING: NEVER EXCEED YOUR VEHICLE MANUFACTURER'S RECOMMENDED TOWING CAPACITY

WEIGHT CARRYING:
 TRAILER WEIGHT: 5,000 LBS.
 TONGUE WEIGHT: 500 LBS.

GROSS LOAD CAPACITY WHEN USED AS A STRAIGHT LINE PULL:
 9,000 LBS MAX.

PRO INSTALL TIME: 45 MIN.
NOVICE INSTALL TIME: 90 MIN.

IF YOU ARE HESITANT TO UNDERTAKE THIS TASK ON YOUR OWN, CONTACT AN AUTHORIZED CURT INSTALLER FOR ADDITIONAL ASSISTANCE.

INSTALLATION REQUIRES:

RATCHET	TORQUE WRENCH	SOCKET 3/4"
POWER DRILL	DRILL BIT 17/32"	AVIATION SHEARS
CENTER PUNCH	SAFETY GLASSES	SOCKET EXTENSION 9"

INSTALLATION TIPS:

- BEFORE YOU BEGIN INSTALLATION, READ ALL INSTRUCTIONS THOROUGHLY.
- TO EASE INSTALLATION, 2 PEOPLE MAY BE REQUIRED.
- USING PROPER TOOLS WILL GREATLY IMPROVE THE QUALITY OF THE INSTALL AND REDUCE THE TIME REQUIRED.

LEVEL OF DIFFICULTY: MODERATE

EASY	MODERATE	CHALLENGING
	DRILLING REQUIRED	
	FASCIA TRIMMING MAY BE REQUIRED	
	FISHWIRE REQUIRED	
	REVERSE FISHWIRE	

VEHICLE PHOTO:



REPRESENTATIVE PHOTO

HITCH ILLUSTRATION:

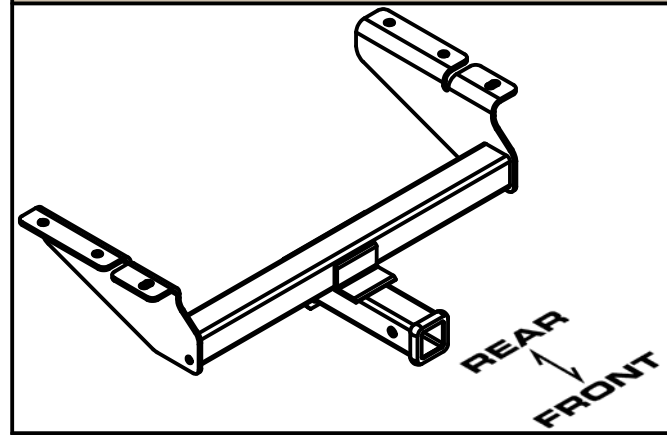

MAKE SURE YOUR HITCH MATCHES

PERIODICALLY CHECK THIS RECEIVER HITCH TO ENSURE ALL FASTENERS ARE TIGHT AND ALL STRUCTURAL COMPONENTS ARE SOUND
 CURT Manufacturing LLC. warrants this product to be free of defects in material and/or workmanship at the time of retail purchase by the original purchaser. If the product is found to be defective, CURT Manufacturing LLC. may repair or replace the product at their option, when the product is returned, prepaid, with proof of purchase. Alteration to, misuse of, or improper installation of this product voids the warranty. CURT Manufacturing LLC.'s liability is limited to repair or replacement of products found to be defective, and specifically excludes liability for incidental or consequential loss or damage.

INSTALLATION WALKTHROUGH:

Parts List			
ITEM	QTY	PART NUMBER	DESCRIPTION
1	6	CM-SP6	.250 x 1.00 x 3.00" SQUARE HOLE SPACER
2	6	1/2-13 x 1 3/4	CARRIAGE BOLT
3	6	HFN 1213	HEX FLANGE NUT
4	2	1_2 FISHWIRE	1/2" FISHWIRE

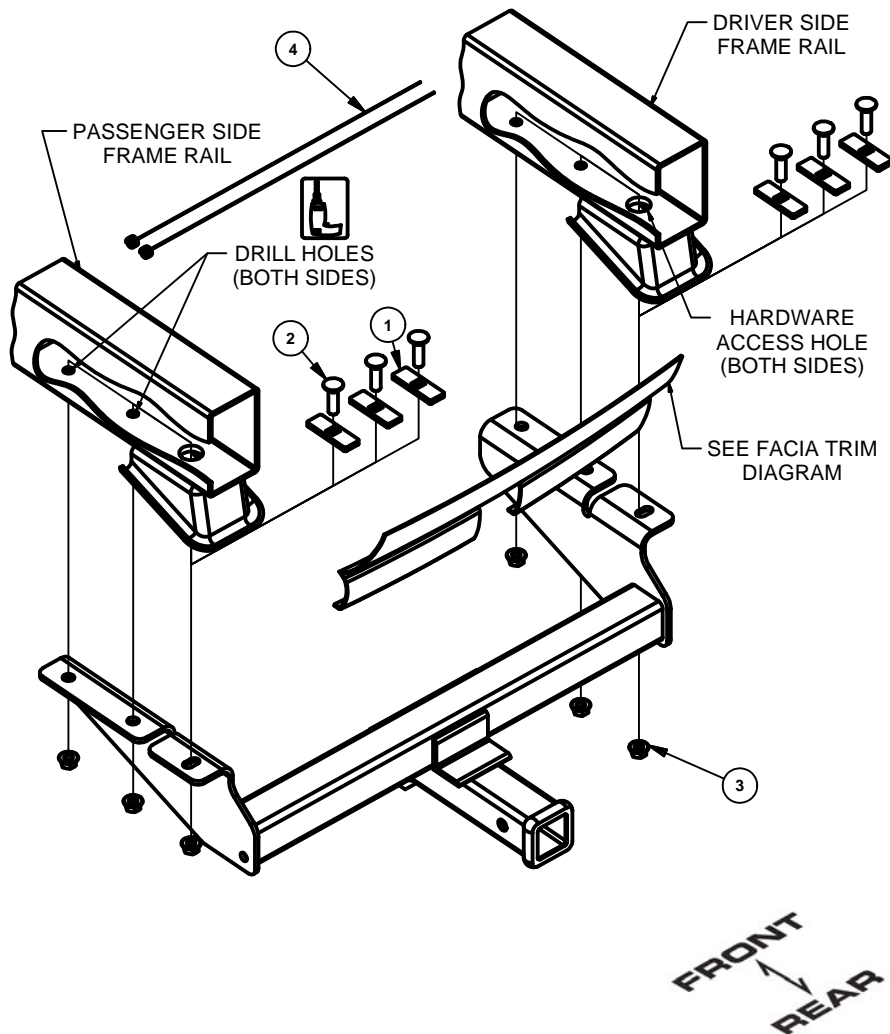

1. Determine if trimming is required on model by raising hitch into position. If needed, mark and trim lower fascia, as shown below, or remove lower fascia and return to owner.
Note: Check for proper fit prior to trimming.

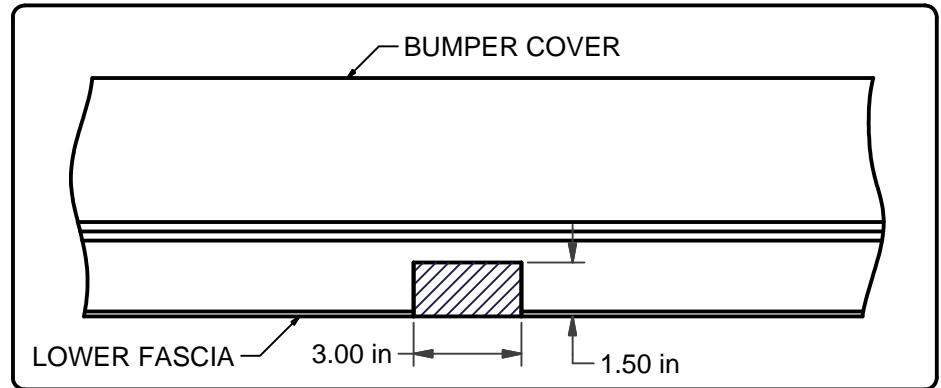

2. Raise hitch into position aligning the access hole with the forward most hole in hitch on both sides.

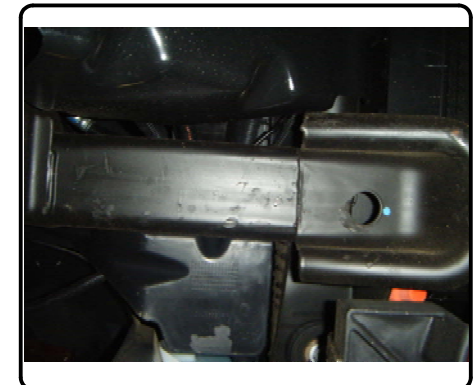
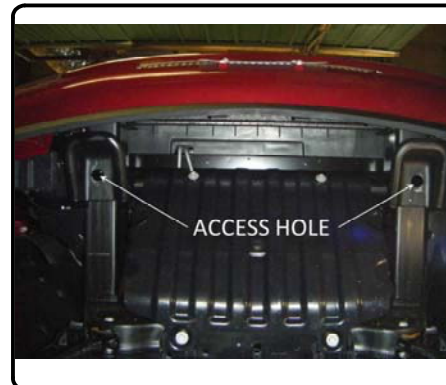

INSTALLATION WALKTHROUGH:

3. Using the hitch as a template, mark the (2) drill holes in both frame rails using a center punch or marker.



4. Lower hitch and drill (4) 17/32" holes marked in Step (3).



5. Fishwire (4) 1/2-13 x 1 3/4" carriage bolts and SP6 spacers through the access holes and out drilled holes.

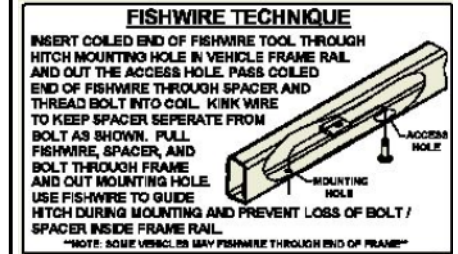

6. Reverse fishwire (2) 1/2-13 x 1 3/4" carriage bolts and SP6 spacers into the access holes.

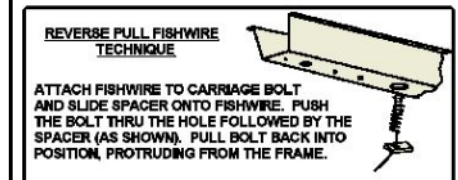

INSTALLATION WALKTHROUGH:

7. Raise hitch into position, being careful not to push hardware inside of frame rail, and secure 1/2-13 flange nuts with 3/4" socket.



8. Torque all 1/2" fasteners to 110 ft-lbs.

Installation is now complete.



31073

CHEVROLET TAHOE, GMC YUKON

GROSS LOAD CAPACITY WHEN USED AS A WEIGHT CARRYING HITCH: 5,000 LBS. TRAILER WEIGHT & 500 LBS. TONGUE WEIGHT.

GROSS LOAD CAPACITY WHEN USED AS A STRAIGHT LINE PULL: 9,000 LBS. MAX. LINE PULL.

*** DO NOT EXCEED VEHICLE MANUFACTURER'S RECOMMENDED TOWING CAPACITY. ***

Parts List			
ITEM	QTY	PART NUMBER	DESCRIPTION
1	6	CM-SP6	.250 x 1.00 x 3.00" SQUARE HOLE SPACER
2	6	1/2-13 x 1 3/4	CARRIAGE BOLT
3	6	HFN 1213	HEX FLANGE NUT
4	2	1_2 FISHWIRE	1/2" FISHWIRE

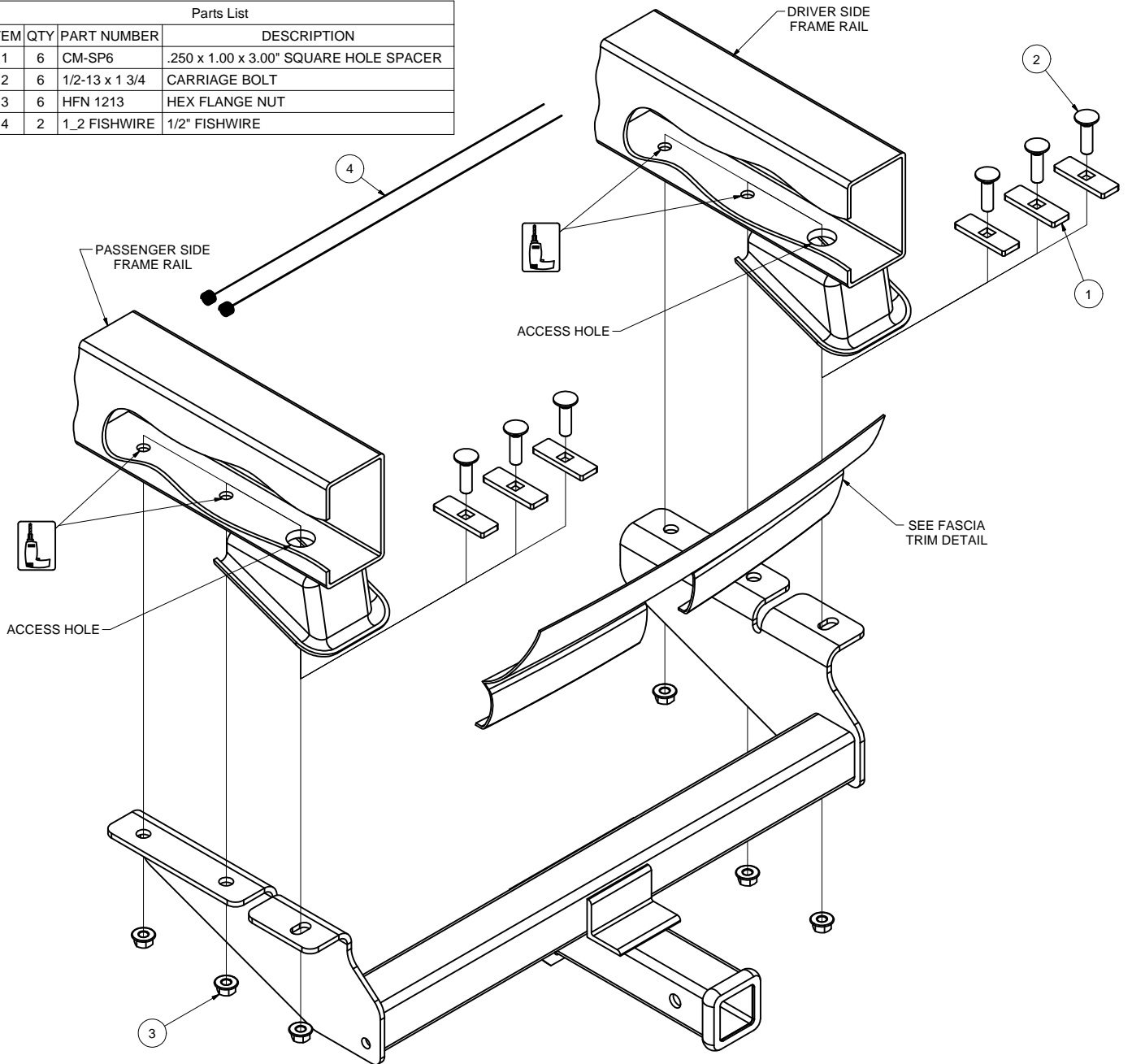

HITCH WEIGHT: 36 LBS.

INSTALL TIME

PROFESSIONAL: 45 MINUTES

NOVICE (DIY): 90 MINUTES

INSTALL NOTES:

- DRILLING REQUIRED
- MAY REQUIRE FASCIA TRIMMING OR REMOVAL (EXCLUDING LT MODELS)

TOOLS REQUIRED

- RATCHET
- TORQUE WRENCH
- 3/4" SOCKET
- AVIATION SHEARS
- DRILL
- 17/32" DRILL BIT
- CENTER PUNCH
- SOCKET EXTENSION



PERIODICALLY CHECK THIS RECEIVER HITCH TO ENSURE THAT ALL FASTENERS ARE TIGHT AND THAT ALL STRUCTURAL COMPONENTS ARE SOUND.

CURT Manufacturing LLC., warrants this product to be free of defects in material and/or workmanship at the time of retail purchase by the original purchaser. If the product is found to be defective, CURT Manufacturing LLC., may repair or replace the product, at their option, when the product is returned, prepaid, with proof of purchase. Alteration to, misuse of, or improper installation of this product voids the warranty. CURT Manufacturing LLC.'s liability is limited to repair or replacement of products found to be defective, and specifically excludes liability for incidental or consequential loss or damage.

**REVERSE PULL FISHWIRE
TECHNIQUE**

ATTACH FISHWIRE TO CARRIAGE BOLT AND SLIDE SPACER ONTO FISHWIRE. PUSH THE BOLT THRU THE HOLE FOLLOWED BY THE SPACER (AS SHOWN). PULL BOLT BACK INTO POSITION, PROTRUDING FROM THE FRAME.

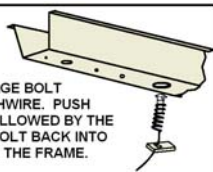
**FISHWIRE TECHNIQUE**

INSERT COILED END OF FISHWIRE TOOL THROUGH HITCH MOUNTING HOLE IN VEHICLE FRAME RAIL AND OUT THE ACCESS HOLE. PASS COILED END OF FISHWIRE THROUGH SPACER AND THREAD BOLT INTO COIL. KINK WIRE TO KEEP SPACER SEPERATE FROM BOLT AS SHOWN. PULL FISHWIRE, SPACER, AND BOLT THROUGH FRAME AND OUT MOUNTING HOLE. USE FISHWIRE TO GUIDE HITCH DURING MOUNTING AND PREVENT LOSS OF BOLT / SPACER INSIDE FRAME RAIL.

NOTE: SOME VEHICLES MAY FISHWIRE THROUGH END OF FRAME

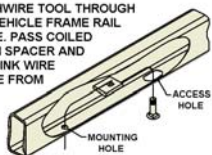

NOTE: DIMENSIONS ARE APPROXIMATE CONFIRM FIT PRIOR TO TRIMMING

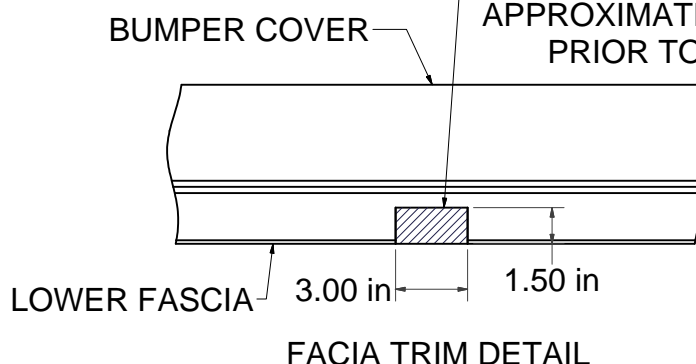
**INSTALLATION STEPS**

1. Determine if trimming is required on model by raising hitch into position. If needed, mark and trim lower fascia, as shown above, or remove lower fascia and return to owner. (See FASCIA TRIM DETAIL)
2. Raise hitch into position aligning the access hole with the forward-most hole in hitch.
3. Using the hitch as a template, mark the (2) drill holes in each frame rail with a center punch or marker.
4. Lower hitch and drill the (4) 17/32" holes marked in Step (3).
5. Fishwire (4) 1/2-13 x 1-3/4" carriage bolts and SP6 spacers through drilled holes. (See FISHWIRE DIAGRAM)
6. Reverse fishwire (2) 1/2-13 x 1-3/4" carriage bolts and SP6 spacers into the access holes. (See REVERSE FISHWIRE DIAGRAM)
7. Raise hitch and secure with 1/2-13 flange nuts, being careful not to push hardware inside of frame rail.
8. Torque all 1/2" fasteners to 110 ft-lbs.

PERIODICALLY CHECK THIS RECEIVER HITCH TO ENSURE THAT ALL FASTENERS ARE TIGHT AND THAT ALL STRUCTURAL COMPONENTS ARE SOUND.

CURT Manufacturing LLC., warrants this product to be free of defects in material and/or workmanship at the time of retail purchase by the original purchaser. If the product is found to be defective, CURT Manufacturing LLC., may repair or replace the product, at their option, when the product is returned, prepaid, with proof of purchase. Alteration to, misuse of, or improper installation of this product voids the warranty. CURT Manufacturing LLC.'s liability is limited to repair or replacement of products found to be defective, and specifically excludes liability for incidental or consequential loss or damage.

DO NOT EXCEED VEHICLE MANUFACTURER'S RECOMMENDED TOWING CAPACITY.

FRONT MOUNTED ACCESSORIES

1) Do not exceed front axle Gross Weight Rating (GAWR). Consult owners manual or specification plate located on driver's door frame. Measure gross front axle weight by placing front wheels of loaded vehicle on a scale.

WARNING: Exceeding GAWR may overload the front axle and/or suspension. This could result in **accident, property damage and personal injury.**

- 2) Reposition front mounted license plate if obstructed.
- 3) Do not obstruct vehicle lights.
- 4) Allow free air flow into grille opening.
- 5) Rear wheel traction may be reduced. This could effect handling. Reduce speed and drive with caution.
- 6) Accessories extend front of vehicle. This may reduce approach angle. Use caution when parking and maneuvering.
- 7) Do not obstruct driver view.

VEHICLE RECOVERY AND WINCHING TIPS

1) Use OEM tow hooks, recovery eyes or a clevis mount for attachment of a tow strap or winch cable.

WARNING: NEVER use a ball and/or ball mount as an anchor point for tow strap or winch cable. Severe personal injury or death could result.

- 2) Observe winch manufacturer's recommendations, cautions and warnings.
- 3) Attach return cable to tow hook or recovery eye when using a snatch block (See figure 1).

CAUTION: Do not attach return cable to winch mount. This may overload winch mount and/or front mounted receiver.

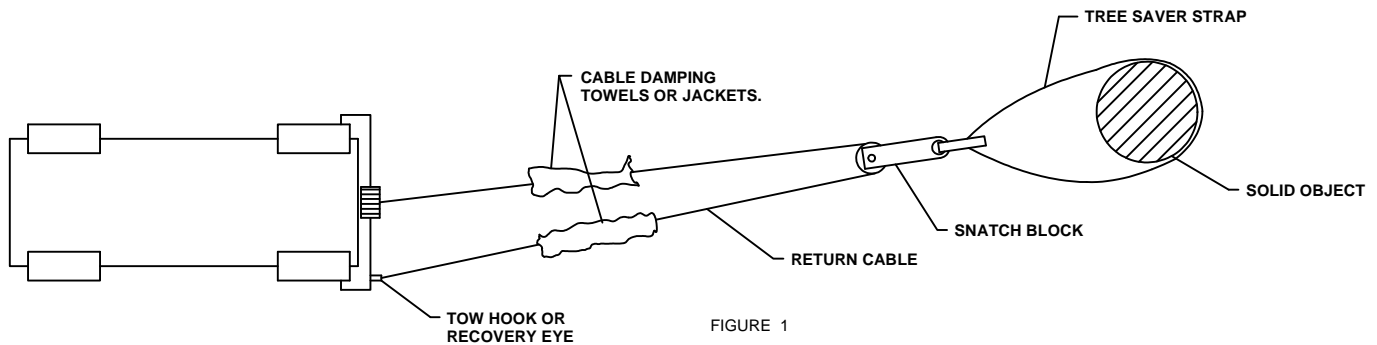

RATING

For **Maximum** line pull rating, winch cable must not exceed:

- 15 degree angle up or down from horizontal (See Figure 2).
- 45 degree angle left or right from straight ahead (See Figure 3).

CAUTION: Exceeding the maximum line pull rating may over load winch, winch mount, and/or front mounted receiver.

