



DUAL PLENUM THROTTLE CABLE KIT INSTALLATION INSTRUCTIONS

860027	Throttle Cable System for Sniper Dual Plenum Intake Manifolds 92mm TB opening Clear Finish
860028	Throttle Cable System for Sniper Dual Plenum Intake Manifolds 92mm TB opening Black Finish
860029	Throttle Cable System for Sniper Dual Plenum Intake Manifolds 102mm TB opening Clear Finish
860030	Throttle Cable System for Sniper Dual Plenum Intake Manifolds 102mm TB opening Black Finish

GENERAL INSTALLATION NOTES:

Please read these instructions completely before beginning the installation.

RECOMMENDED TOOLS/EQUIPMENT FOR INSTALLATION:

5/32" Allen Wrench	5/64" Allen Wrench
5mm Allen Head Wrench	Cutting Pliers or Hacksaw
Drill	5/16" Drill Bit
Marker or Pen	

Before beginning the installation, disconnect the negative battery cable and use wheel chocks to block the vehicle's wheels. Do not attempt to install or adjust the throttle cable while the engine is running.

Make sure the engine, transmission, body and frame are properly grounded. We recommend using anti-seize lubricant on any aluminum threads.

NOTE: The Holley Throttle Cable is designed to be installed with an aftermarket Throttle Pedal. The Holley Throttle Cables are designed to be cut-to-fit. See **Figure 1** and **Figure 2** for the names of the components.

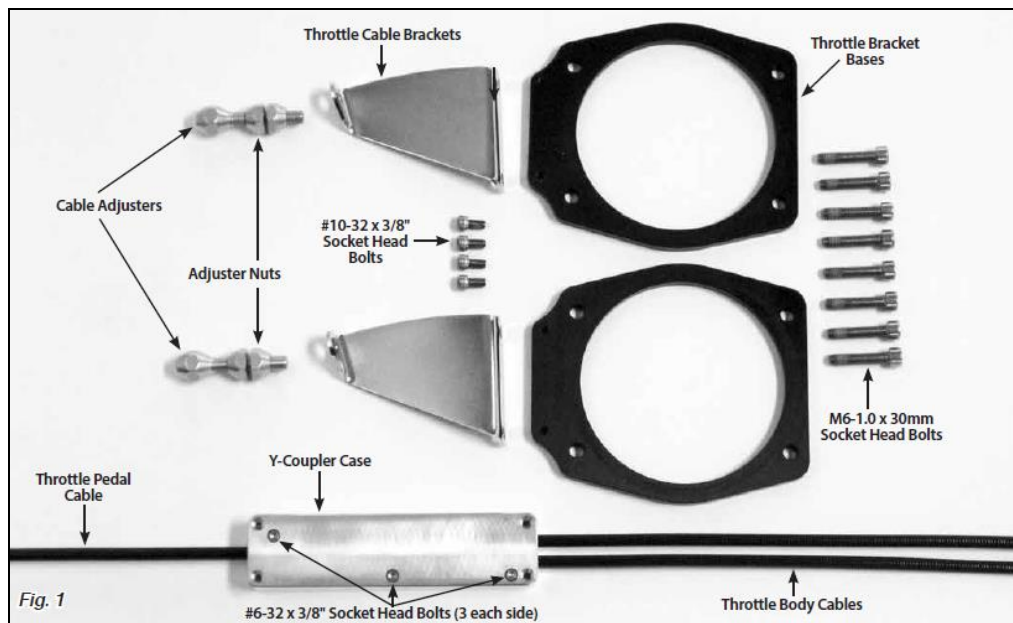

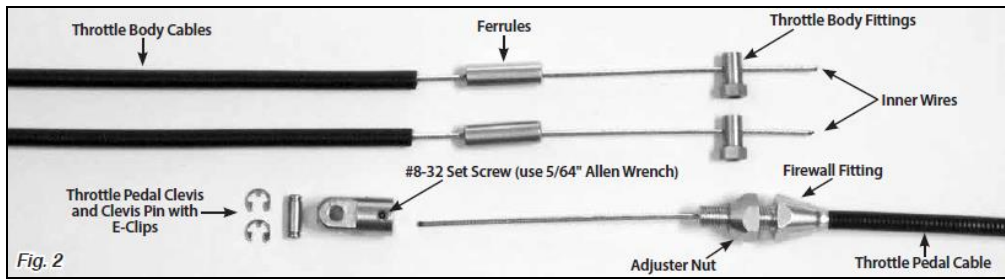

1. Loosely assemble the throttle cable brackets to the throttle bracket bases, using the provided #10-32 x 3/8" socket head bolts. The throttle cable brackets should be installed on the opposite side of the throttle bracket bases from the pre-installed O-rings (**Figure 3**).
2. Remove the throttle bodies from the plenums if they have already been installed. You may discard the original throttle body mounting bolts. Longer bolts are provided in this kit.
3. Make sure that the throttle body mounting surfaces are clean.
4. Make sure the original throttle body O-rings are still in place on the plenum, and that the pre-installed O-rings are still on the throttle bracket bases. Install the throttle bracket bases and throttle bodies onto the plenums using the provided M6-1.0 x 30mm socket head bolts, with the throttle cable brackets pointing towards the rear of the engine. Make sure that the edge of the throttle cable bracket doesn't get caught under the throttle body. Tighten the throttle body mounting bolts using a 5mm Allen wrench. Use a 5/32" Allen wrench to tighten the socket head bolts holding the throttle cable brackets to the throttle bodies (**Figure 4**).
5. Remove the throttle body fittings, the cable adjuster assemblies, and the ferrules from the ends of the new throttle body cables.
6. Remove the front adjuster nut from each of the cable adjusters. Insert the cable adjusters into the throttle cable brackets. Then, position the rear adjuster nuts so that the threaded part of the cable adjusters are approximately centered in the throttle cable brackets. Reinstall the front adjuster nuts (**Figure 5**).

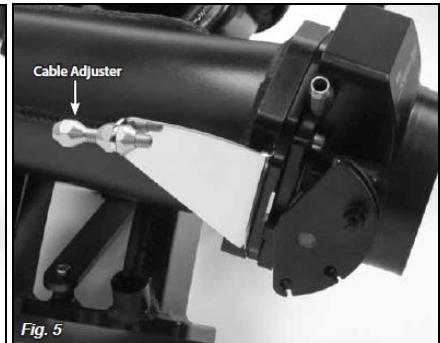
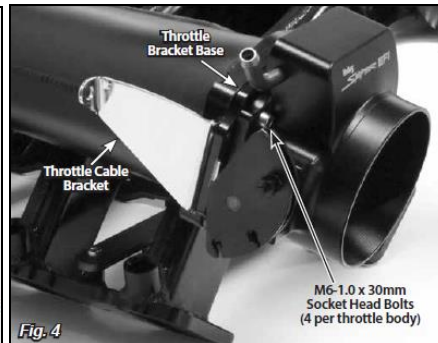
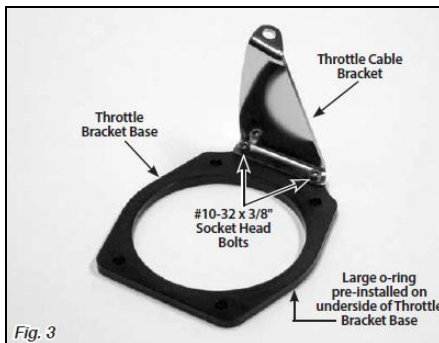

7. Determine where you are going to mount the Y-coupler case assembly. It may be mounted to the firewall or to a custom bracket (not supplied) on the intake manifold or elsewhere. Loosely mount the Y-coupler case assembly in place.
8. Route the throttle body cables up to the cable adjusters. If the Y-coupler case is mounted on the engine itself, mark both of the throttle body cable housings where they bottom out in the cable adjusters. If the Y-coupler case is NOT mounted on the engine itself, mark the throttle body cable housings 2" beyond the cable adjusters. NOTE: If the Y-coupler case is not mounted on the engine, the cable housings must NOT be straight between the Y-coupler case and the cable adjuster. There must be some slack to allow for engine movement (**Figure 6**).

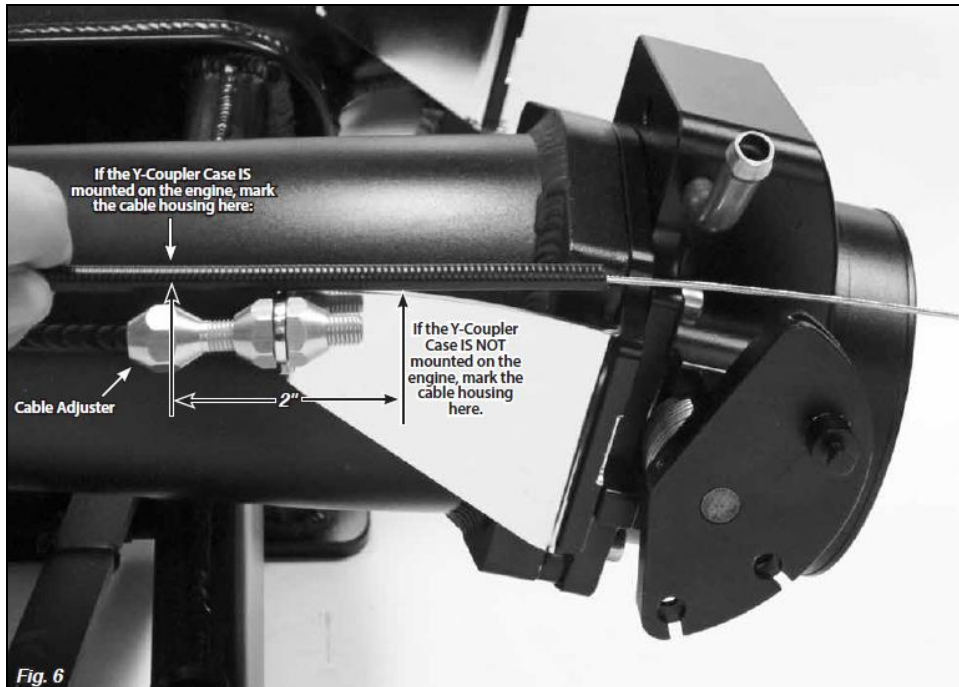

Fig. 6

9. Label each of the cable housings as to which side they go to. Remove the Y-coupler case assembly from its mounting point. Using a 5/64" Allen wrench, loosen the six #6-32 x 3/8" socket head bolts in the Y-coupler case assembly enough to be able to pull out the throttle body cable housings.
10. Remove the throttle body cable housings from the Y-coupler case assembly and slide them off of the inner wires. Make sure that the cable housings are completely removed from the inner wires!
11. Cut the cable housings at your marks with heavy duty 8" diagonal cutting pliers or a hacksaw. We recommend Klein brand Diagonal Cutting Pliers, # D2000-28 available at The Home Depot or through W. W. Graingers, part # 4A838.
12. If the aftermarket Throttle Pedal has not already been installed, install the Throttle Pedal now, following the instructions that are provided with the Throttle Pedal.
13. The throttle cable hole in the firewall must line up with the hole in the Throttle Pedal. Determine exactly where the throttle pedal cable needs to pass through the firewall and drill a 5/16" hole.
14. Pull the throttle pedal cable housing out of the Y-coupler case. Remove the throttle pedal cable housing from the inner wire.
15. On the pedal end of the cable housing, remove the adjuster nut from the firewall fitting. Insert the firewall fitting through the firewall from the engine side, and reinstall the adjuster nut (**Figure 7**).

NOTE: The firewall fitting **MUST** point directly at the hole in the top of the upper arm of the throttle pedal, so that the inner wire does not rub excessively against the inside of the firewall fitting. Some aftermarket Throttle Pedals for specific applications come with offset washers. If your Throttle Pedal came with offset washers, they must be installed with the firewall fitting. Place one offset washer onto the firewall fitting before inserting the firewall fitting into the firewall. After the firewall fitting is inserted into the firewall, install the other offset washer and the adjuster nut on the passenger compartment side of the firewall fitting. Rotate the offset washers opposite one another until the firewall fitting is pointed directly at the hole in the top of the upper arm on the pedal.

16. Route the throttle pedal cable housing up to the end of the Y-coupler case, and mark the cable housing where it meets the end of the Y-coupler case.

If the Y-coupler case is **NOT** mounted on the engine itself, make a second mark on the throttle pedal cable housing 3/4" further away from the firewall. If the Y-coupler case **IS** mounted on the engine itself, make a second mark on the throttle pedal cable housing 2-3/4" further away from the firewall.

NOTE: If the Y-coupler case is mounted on the engine, the cable housing must **NOT** be straight between the firewall and the Y-coupler case. There must be some slack to allow for engine movement.

17. Make sure that the cable housing is completely removed from the inner wire. Cut the cable housing at your second mark with heavy duty 8" diagonal cutting pliers or a hacksaw.

- Slide all three cable housings onto their respective inner wires. Position each cable housing so that the end of each cable housing is butted up against the inner end of the cable recess in the Y-coupler case. Approximately 3/4" of each housing should be inside the Y-coupler case (**Figure 8**). Reassemble the Y-coupler case and tighten the #6-32 x 3/8" socket head bolts, using a 5/64" Allen wrench.

Pull each of the inner wires through its full range of travel to make sure nothing is binding.

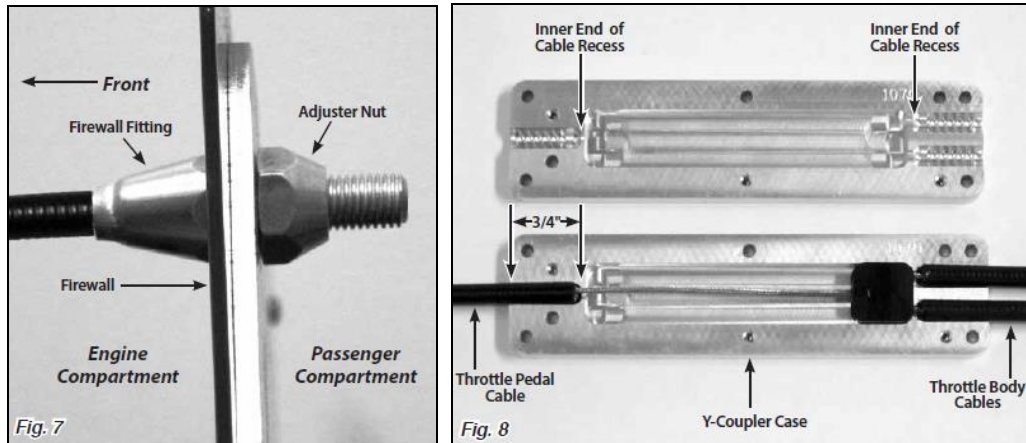

- Mount the Y-coupler case assembly in place. Put the ferrules on both of the throttle body cable housings back into place. Thread the throttle body cable inner wires through the cable adjusters, and insert the throttle body cable housings into the cable adjusters.
- Loosen the #8-32 x 3/16" set screw in one of the throttle body fittings using a 5/64" Allen wrench. Insert the end of the inner wire into the throttle body fitting, and slide the throttle body fitting all the way to the cable adjuster. Pull on the inner wire until it bottoms out inside the Y-coupler case.

Lay the cable in the groove on the throttle body pulley. While pulling the inner wire tight, mark the inner wire where it lines up with the furthest edge of the hole in the pulley where the fitting goes (**Figure 9**).

- Use a sharp pair of wire cutters to cut the inner wire at that mark. Slide the throttle body fitting to the end of the inner wire until the end of the inner wire is flush with the throttle body fitting. Tighten the set screw against the inner wire using a 5/64" Allen wrench. Rotate the throttle pulley back and insert the throttle body fitting and inner wire into place on the throttle body.
- Repeat Step 20 & Step 21 for the second throttle body.
- Inside the passenger compartment, install the throttle pedal clevis and clevis pin with the E-clips onto the throttle pedal. Pull all of the slack out of the throttle pedal cable inner wire. Hold the throttle pedal clevis in the horizontal position and hold the throttle pedal cable inner wire up next to the clevis. Mark the inner wire where it lines up with the end of the clevis that is closest to the firewall (**Figure 10**).

Measure 3/8" further towards the drivers seat on the inner wire, and cut the inner wire there with a sharp pair of wire cutters.

- Thread the end of the inner wire into the clevis. Pull all of the slack out of the inner wire, and tighten the #8-32 x 3/16" set screw in the clevis using a 5/64" Allen wrench (**Figure 11**).
- Check for proper operation of the throttle and adjust as necessary. Make sure there is no binding in the throttle linkage and that the throttle returns to the closed position when the pedal is released.

NOTE: Once the Throttle Cable is installed, make sure that the Throttle Pedal is completely floored when the throttle is wide open. If the Throttle Pedal is not completely floored at wide open throttle, you will need to either adjust the pedal itself or install a pedal stop.

