

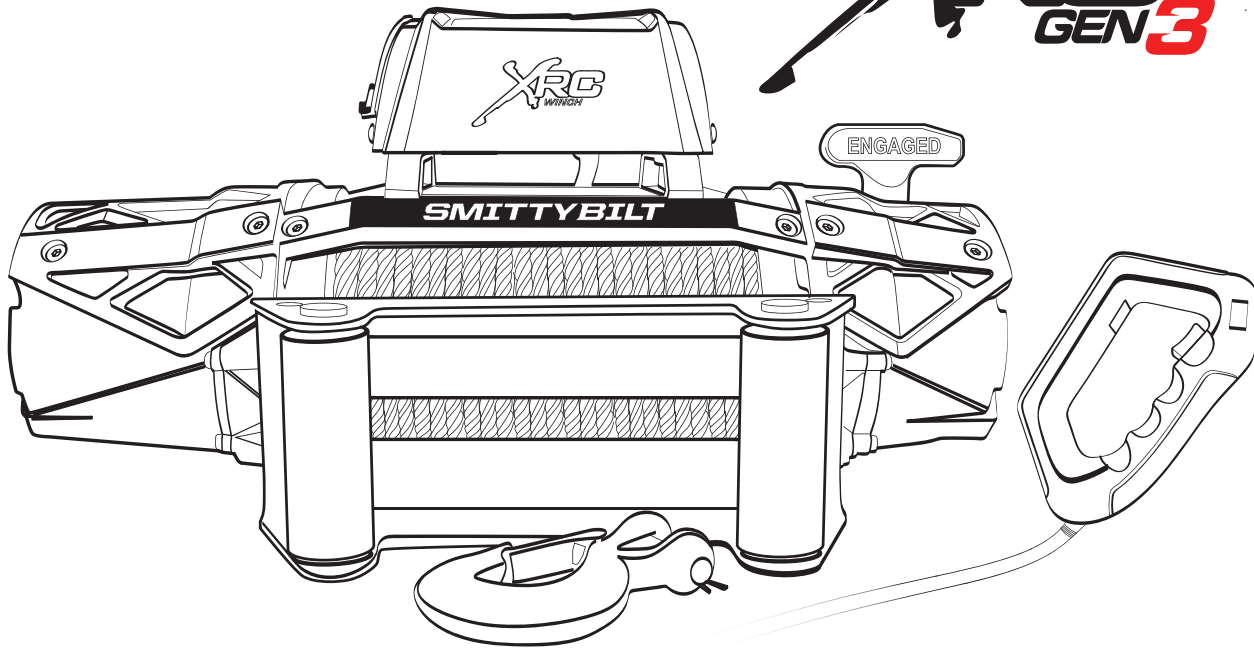

XRC 9,500 LB  
XRC 12,000 LB



XRC GEN3 INSTRUCTION MANUAL



**#97695**

**XRC Gen3 9.5K**

with 4-Way Roller Fairlead and Steel Cable

**#97612**

**XRC Gen3 12K**

with 4-Way Roller Fairlead and Steel Cable

**#98695**

**XRC Gen3 9.5K COMP SERIES**

with Aluminum Hawse Fairlead and Synthetic Rope

**#98612**

**XRC Gen3 12K COMP SERIES**

with Aluminum Hawse Fairlead and Synthetic Rope

XRC Gen3 Winches include:

- 9.5k or 12k XRC Gen3 Winch
- Steel Cable or Synthetic Rope
- 4-Way Roller or Hawse Fairlead
- Movable Control Box Mounting Bracket
- Remote Controller with Load Indicator
- Forged Winch Hook

**New Remote Controller Features .....3**

**New Control Box Features .....4**

**Safety Precautions .....5**

**Operation Warnings .....6**

**Winch Operation .....7**

**Winch Mounting .....8**

**INSTALLATION INSTRUCTIONS**

**Electrical Connections .....10**

**Auxiliary 12v Power Post .....11**

**Armor Plate Removal .....12**

**Control Box Mounting .....14**

**Wiring for DRL and Tie Bar Lighting .....16**

**Motor Wire Nuts Supplement .....17**

**Product Specifications .....18**

**Understanding IP Ratings .....19**

**Service Parts .....20**

**Troubleshooting .....22**





# NEW! XRC Gen3 Winch Remote Controller Features



Direction switch (IN/OUT)

Power switch

**What do the colored lights on the Load Indicator mean?**

**COLOR: BLUE**

**READY**

Winch is ready to start

**COLOR: GREEN**

**LOADING**

Winch is operating within safe levels

**COLOR: YELLOW**

**MAX LOAD**

Winch is operating at maximum load

**COLOR: RED**

**OVERLOAD STOP!!!**



**Time to use snatch block or other assist**

Power IN indicator light

Power OUT indicator light

Power IN switch

Power OUT switch

To power IN:  
Press the power IN switch. The switch cover and IN indicator will light up. Use the power switch to control the winch.

**Note:** If you press the power IN switch a second time, the remote will go into neutral and will not power the winch.

To power OUT:  
Press the power OUT switch. The switch cover and IN indicator will light up. Use the power switch to control the winch.

**Note:** If you press the power OUT switch a second time, the remote will go into neutral and will not power the winch.

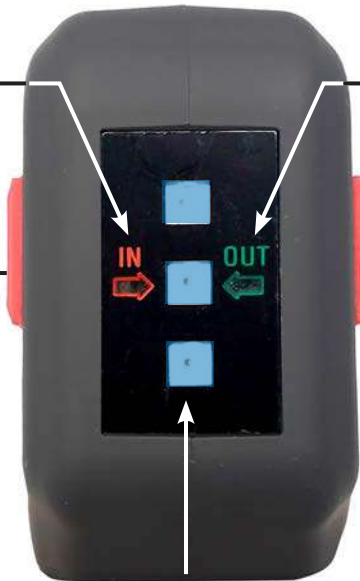

Load Indicator

**IMPORTANT:** Load indicator lights will let you know approximately how much load is on your winch based on the chart above. Maximum pulling power is only achieved when pulling from the first layer of rope on the drum. Avoid continuous winching at high load and always check motor temperature frequently. If motor is too hot to touch, allow to cool before you continue your recovery. It is recommended to re-access your recovery and consider the use of a snatch block when recovery exceeds full load and/or when red over load lights begin to light up.



# NEW! XRC Gen3 Winch Remote/Control Box Features



## Magnetic Mounting Pads

Strong neodymium magnets enable remote to be secured to any ferromagnetic material

## LED Flashlight

To use LED light in the remote, ensure remote is plugged in and then press the LED light switch to power the light on and off.



## Control Box Socket

Connect the remote to the Control Box by lining up the arrow on top of the plug with the extended Push Tab on the control box. Push plug straight into socket until you feel the push tab engage and lock the plug into the socket. The three blue indicator lights will turn on, indicating the controller is connected.

To remove the remote controller, depress the Push Tab, then pull out the plug.

## Auxiliary 12V Accessory Power Post

For quick use of 12 volt accessories without popping the hood. Perfect for powering small items such as an air compressor.

The power post is protected with a 50-Amp automatic circuit breaker. In case of a ground short, or thermal overload, the breaker will trip, it will automatically reset itself after a short period of time after the fault is removed.

To use, open the cover to expose power post. Attach accessory POSITIVE lead to the post. Attach accessory NEGATIVE lead to a suitable ground location on your vehicle. NOTE: you may remove the button head bolt to connect a power wire with an eyelet.



**⚠ WARNING ⚠**

NEVER operate winch with less than 10 wraps of Synthetic rope around the drum. The terminal end is to prevent the rope from unraveling, it is NOT a load bearing attachment point. Improper installation and/or spooling out to last layer will put a load on the terminal end and the rope will release from the terminal. Always re-spool winch rope under minimum 1000lb. Load before each use.

\*For more information see owners manual\*

- Inspect rope before each use
- Protect the rope from coming in contact with sharp or rough objects that may damage, cut or weaken the rope
- Never use rope over a rough surface without chafe protection
- Never shock load winch rope
- Never bend rope around unprotected, sharp corners
- Always use an aluminum hawse fairlead with synthetic ropes
- Never hook rope back onto itself
- Always wash rope after use
- Manufacturer is not responsible for the results of misuse, misapplications, faulty installation, abuse, vehicle condition or modification of the product in any way.



## Safety Precautions

### SAFETY PRECAUTIONS

Improper equipment operation may cause damage to equipment. Observe all safety precautions for personal safety and the safety of others. Failure to comply may cause death or serious personal injury.

Read the following carefully before attempting to operate your winch. Keep the instructions for future reference.

- 1. DRESS PROPERLY.**
  - DO NOT wear loose clothing or jewelry. They can be caught in moving parts.
  - Wear leather gloves when handling winch cable. Do not handle cable with bare hands as broken wires can cause injuries.
  - Non-skid footwear is recommended.
- 2. KEEP A SAFE DISTANCE.**
  - Ensure that all persons stand well clear of winch cable and load during winch operation, 1.5 times the cable length recommended. If a cable pulls loose or breaks under load, it can lash back and cause serious personal injury or death.

**DO NOT STEP OVER THE CABLE.**

  - All visitors and onlookers should be kept away from the work area.
  - Keep proper footing and balance at all times.
- 3. DO NOT ABUSE THE CORD.**
  - Never carry your winch by the cord or yank it to disconnect it from the receptacle.
  - Keep cord from heat, oil and sharp edges.
- 4. DO NOT OVERWORK THE WINCH.**
  - If the motor becomes uncomfortably hot to touch, stop and let it cool for a few minutes.
  - DO NOT maintain power to the winch if the motor stalls.
  - DO NOT exceed maximum line pull ratings shown in tables. Shock loads must be avoided.
- 5. AVOID UNINTENTIONAL OPERATION.**
  - Winch clutch should be disengaged and the hook secured when not in use and fully engaged when in use.
- 6. CHECK DAMAGED PARTS.**
  - Before using, you should check your winch carefully. Any part that is damaged should be properly repaired or replaced by an authorized service center.
- 7. REPAIR YOUR WINCH.**
  - When repairing, use only identical replacement parts or it may cause considerable danger for the user.
- 8. RE-SPOOL THE CABLE.**
  - Leather gloves must be worn while re-spooling. To re-spool correctly, it is necessary to keep a slight load on the cable. See item 16 of operational warnings section.
  - Do not allow the cable to slide through your hand and do not approach the winch too closely.
  - Turn off the winch and repeat the procedure until all the cable except for approximately 1 meter (3 feet) is in.
  - Disconnect the remote control switch and finish spooling in cable by rotating the drum by hand with clutch disengaged.
  - On hidden winches, spool in cable under power but keep hands clear.



## Operational Warnings

### OPERATIONAL WARNINGS

**Read the following carefully before attempting to operate your winch and keep the instructions for future reference. Smittybilt electric winches are intended for recreational self-recovery usage only.**

1. The uneven spooling of cable, while pulling a load, is not a problem, unless there is a cable pile up on one end of the drum. If this happens reverse the winch to relieve the load and move your anchor point further to the center of the vehicle. After the job is done, you can unspool and rewind for a neat lay of the cable.
2. Store the remote control switch inside your vehicle where it will not become damaged, inspect it before you plug it in.
3. When ready to begin spooling in, plug in remote control switch with clutch disengaged, do not engage clutch with motor running.
4. Never connect the hook back to the cable, this causes cable damage. Always use a sling or chain of suitable strength.
5. Observe your winch while winching, if possible while standing at a safe distance. Stop the winching process every meter or so to assure the cable is not pulling up in one corner. Jamming the cable can break your winch.
6. Do not attach tow hook to winch mounting plate, they must be attached to vehicle frame.
7. The use of a snatch block will aid recovery operations by providing a doubling of the winch capacity and a halving of the winching speed, and the means to maintain a direct line pull to the center of the rollers. When double loading during stationary winching, the winch hook should be attached to the chassis of the vehicle.
8. Ensure "D" or bow shackles with adequate load rating are used in conjunction with an approved tree trunk protector to provide a safe anchor point.
9. When extending winch cable, ensure that at least five wraps of cable remain on drum at all times. Failure to do this could result in the cable parting from the drum under load. Serious personal injury or property damage may result.
10. All winches are provided with a red cable marking to identify that 5 cable wraps remain on the winch drum when this mark appears at the rollers (10 wraps for synthetic rope). No recovery should be attempted beyond this marking (wire rope only).
11. Since the greatest pulling power is achieved on the inner most layer of your winch, it is desirable to pull off as much line as you can for heavy pulls (you must leave at least 5 wraps minimum on the drum--red cable). If this is not practical use a snatch block and double line arrangement.
12. Draping a heavy blanket or similar object over the extended winch cable is recommended as it will dampen any back lash should a failure occur.
13. Neat, tight spooling avoids cable binding, which is caused when a load is applied and the cable is pinched between the others. If this happens, alternatively power the winch in and out. Do not attempt to work a bound cable under a load, free by hand.
14. To prevent vehicle rollback, apply blocks behind wheels when vehicles are on an incline.
15. Battery
  - Be sure that the battery is in good condition. Avoid contact with battery acid or other contaminants.
  - Always wear eye protection when working around a battery.
  - Have the engine running when using the winch, to avoid flattening the battery.
16. Winch cable
  - Be sure that the cable is in good condition and is attached properly.
  - Do not use the winch if cable is frayed.
  - Do not move the vehicle to pull a load.
  - Do not replace the cable with a cable of lesser strength.
  - The life of the cable is directly related to the use and care it receives. Following its first and subsequent





## Winch Operation

uses, a cable must be wound on to the drum under a load of at least 500lbs (230kgs) or the outer wraps will draw into the inner wraps and severely damage the cable during winching. The first winch use should be a familiarization run while in a relaxed, non recovery situation. Spool out the cable until the red cable mark appears (about 5 wraps on the drum), then rewind the cable on the drum under a load of 500lbs (230kgs) or more. This will slightly tension and stretch the new cable and create a tight cable wrap around the drum. Failure to do so may result in cable damage and reduced cable life.

- When the cable is replaced, be sure to apply Loctite, or an equal compound, to the cable clamp thread. Tighten the clamp screw properly but do not over tighten. The Loctite will prevent loosening of the screw in arduous conditions. Loctite 7471 primer and 222 threadlocker are recommended.

17. Do not attempt to exceed the pulling limits of this winch.
18. Do not drive your vehicle to assist the winch in any way. Vehicle movement in combination with winch operation may overload the cable, the winch itself or cause damaging shock loads.
19. Shock loads when winching are dangerous! A shock load occurs when an increase force is suddenly applied to the cable. A vehicle rolling back on a slack cable may induce a damaging shock load.
20. The winches shown in this manual are solely for vehicle and boat mounted, non-industrial applications.
21. Do not use winch in hoisting applications due to required hoist safety factors and features.
22. Do not use the winch to lift, support or otherwise transport personnel.

## WINCH OPERATION

**The best way to get acquainted with how your winch operates is to make a few test runs before you actually need to use it. Plan your test in advance.**

**Remember you can hear your winch as well as you can see it operate. Get to recognize the sound of a light steady pull, a heavy pull, and sounds caused by load jerking or shifting. Soon you will gain confidence in operating your winch and its use will become second nature to you.**

## STANDARD OPERATING PROCEDURE

1. Ensure the vehicle is secure by applying the parking brake or chocking the wheels.
2. Pull out the winch cable the desired length and connect to an anchor point. The winch clutch allows rapid uncoiling of the cable for hooking onto the load or anchor point. The shifter tab located on the gear housing of the winch operates the clutch as follows:
  - a. To disengage the clutch, move the clutch shifter tab so that the "FREE SPOOL" text is facing forward. Cable may now be free spooled off the drum.
  - b. To engage the clutch, move the clutch shifter tab into the "ENGAGED" position. The winch is now ready for pulling.
  - c. Line the tab on the inside of the remote socket end with the groove on the remote plug on the control box.

***You should always "Free spool" the winch outward.***
  - d. Push the switch on the side of the remote to select the direction you want the winch to operate, then pull the trigger to operate the winch.
  - e. The remote features a magnet on the front which enables you to keep the remote off of the ground by having it placed on your vehicle, bumper, etc.

**After turning on the winch or plugging in the remote you must always select a direction in order for the trigger to operate.**

3. Recheck all cable rigging before proceeding.
4. Plug in the winch hand control. It is recommended that the winching operation takes place from the driver's position to ensure safe operation.
5. To commence winching operation, start vehicle engine, select neutral in transmission, maintain engine speed at idle.
6. Operate the remote control switch to the IN or OUT position until the vehicle has been retrieved. Regularly check the winch to ensure cable is winding onto the drum evenly.

## **WINCH MOUNTING**



**The fitment of winches and/or a frontal protection system may affect the triggering of SRS airbags. Check that the mounting system has been tested and approved for winch fitment in the airbag-equipped vehicle. Failure to comply may cause death or severe personal injury.**

The winch is to be mounted into a suitable steel mounting frame using the 4-point foot mounting system either a horizontal or vertical plane. It is very important that the winch be mounted on a flat surface so that the three sections (motor, cable drum and gear housing) are properly aligned.

Winch mounting frames and/or frontal protection systems are suggested to suit most popular vehicles. Winch frames are packaged with detailed fitting instructions.

The winch should be secured to the mounting with the M10x 32mm bolts and spring washers provided. Winch plate must be at least 6mm thick. Thicker winch plates may require longer bolts (not included). Ensure winch mounting bolts protrude past the top surface of the square nut.

The roller fairlead is to be mounted so as to guide the rope onto the drum evenly.

**NOTE: The gear box and motor assembly are not clockable. Attempting to do so can cause damage to the winch and voids warranty.**

**DO NOT FORCE CLUTCH HANDLE.**

**Rotate drum to align gear in order to free spool if needed.**

**ROPE IS NOT COVERED UNDER THE MANUFACTURER WARRANTY. THIS IS A NORMAL WEAR AND TEAR ITEM.**

**Inspect rope before first use during the mandatory pre-stretching. Any defects must be noted before initial use.**

**Improper use, inadequate fairlead to bumper clearances, abuse, neglect, chafing damage are not covered by any warranty.**



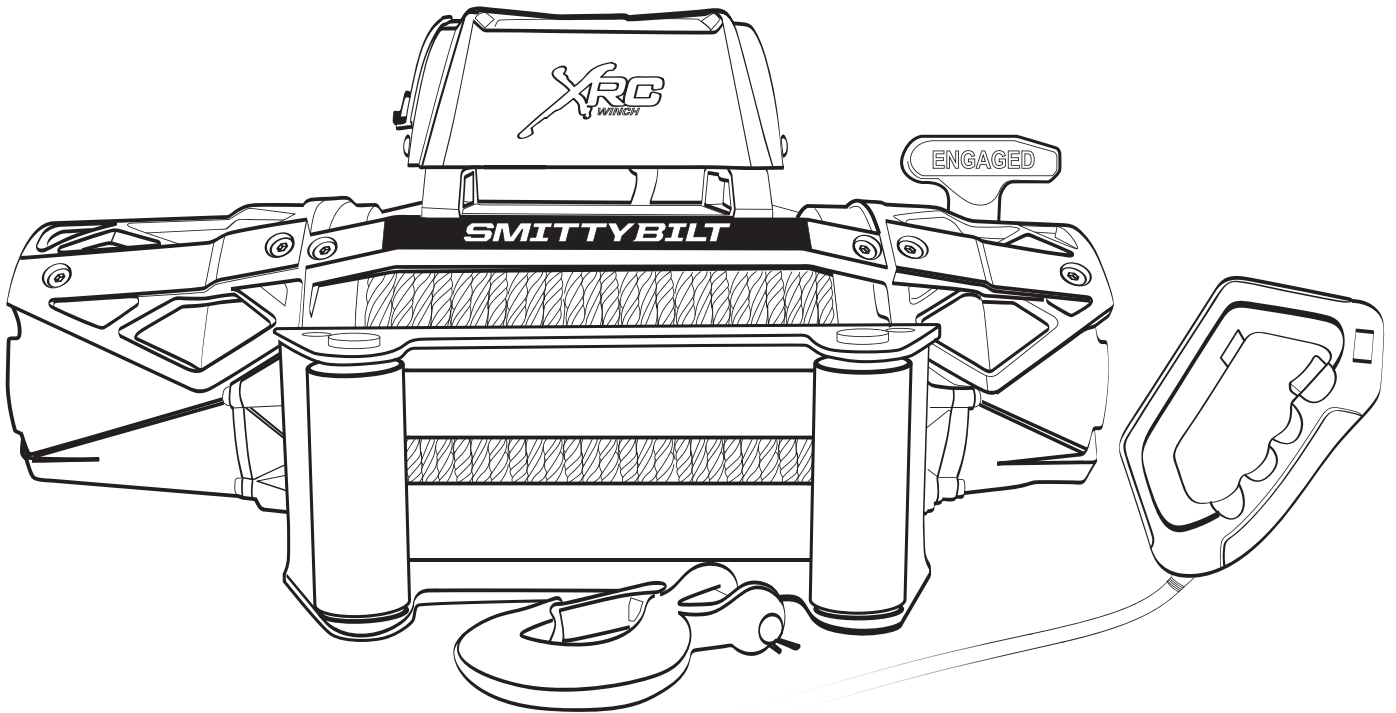

# INSTALLATION INSTRUCTIONS

## Electrical Connections

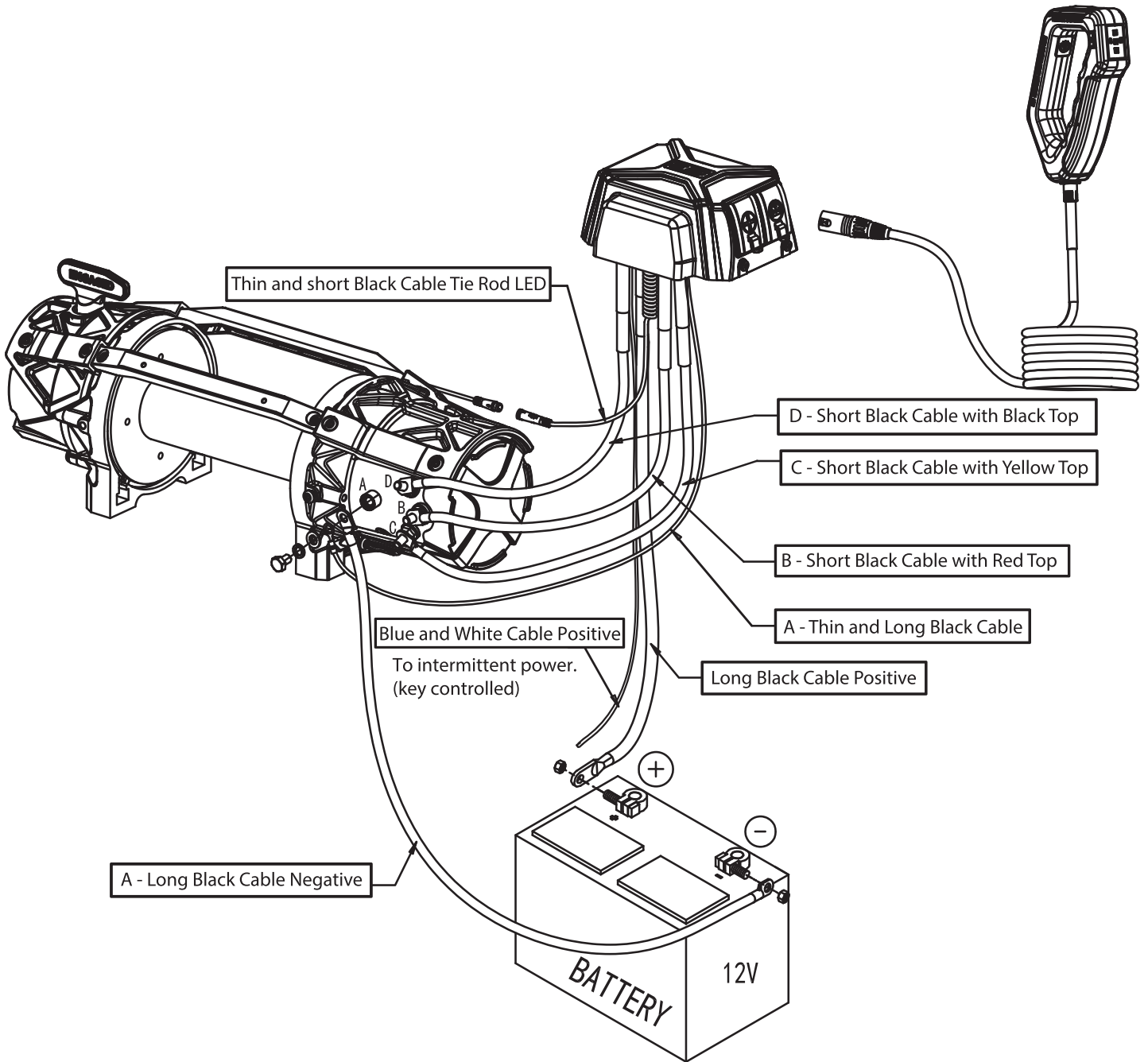

**WARNING: Do not alter, change or amend winch wiring/connections. Doing so can cause property or bodily injury and voids warranty.**



## Auxiliary 12v Power Post

XRC Gen3 winches feature an auxiliary positive power post on the control box for quick use of 12 volt accessories with out popping the hood. Perfect for powering small items such as an air compressor.

Power post is protected with a 50-Amp automatic circuit breaker. In case of a ground short, or thermal overload, the breaker will trip, it will automatically reset itself after a short period of time after the fault is removed.

Step 1: Open cover to expose power post. (Fig 1).

Step 2: Attach accessory positive lead to power post (Fig 2).

Step 3: Attach accessory negative lead to a suitable ground location on your vehicle.

Note: You may remove the button head bolt to connect a power wire with an eyelet.





## Armor Plate Removal

XRC Gen3 winches feature removable high-impact plastic armor to protect the motor and gear box. They can be permanently removed to better winch clearance, or they can be temporarily removed so they can be custom painted to add some contrasting color to the front of your vehicle. T-30 torx bit and 4mm Allen wrench are needed to remove the armor plates.

**Note: Painting HDPE requires prep work for proper paint adhesion. Contact your local paint supplier for the recommended adhesion promotors, primers and paint.**



STEP 1: Remove button head bolts, holding down the armor plates on to the motor (Fig. 1), then gently slide the plate to the left to remove it (Fig 2).

Photos on following page...

STEP 2: Remove button head bolts, holding down the armor plates on to the gear box (Fig. 3), remove the Allen head bolt holding the gear lever in place (Fig 4).

Use a 4mm Allen wrench and completely remove screw. Not orientation of lever so it can be installed in the same position, then pull straight up on the gear lever. Gently slide the plate to the right to remove it (Fig 5/6).

STEP 3: If you are planning on running no armor, it is crucial to reinstall four of the short bolts you removed in order to properly secure the tie bar/rod. Re-install one button head bolt into each of the empty tie rod mounting holes. Take care that you do not over-tighten the bolts (Fig 7).

STEP 4: To re-install, simply slide the plate back on to the winch and secure with the button head bolts you removed in prior steps. Do not over-tighten bolts.

## Armor Plate Removal

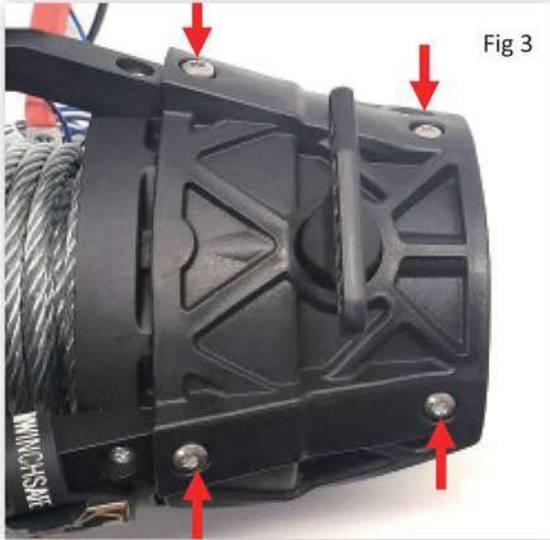

## Control Box Mounting (Over Drum)

XRC Gen 3 control box can be mounted over the drum or over the motor with the included bracket kits. Over-the-motor mounting will provide additional clearance for power wires when mounting the winch close to a grille.

Step 1: Locate the control box brackets and hardware (Fig 1).

Step 2: Attach the control box mounting brackets to the bottom of the control box with button head bolts. Note front to rear orientation (Fig 1 & 2).

Step 3: Attach the control box to the tie bars by placing front of bracket over the front tie bar, then line up the rear mounting holes with the threaded holes in the rear tie bar. Secure with button head bolts. Ensure both bolts are started before tightening. Note: you may loosen tie bars slightly to aid in alignment of control box mount (Fig 3 & 4).

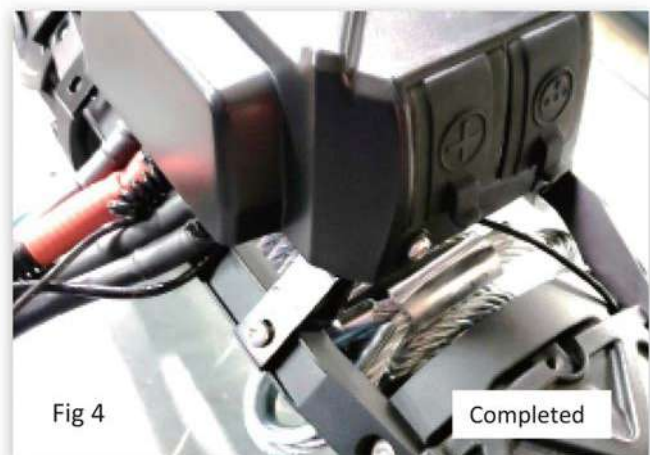
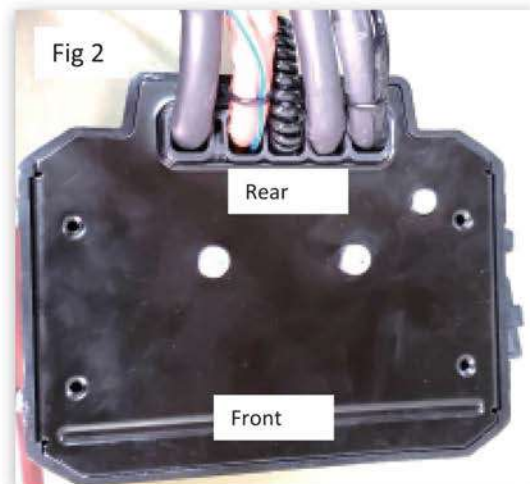



## Control Box Mounting (Over Motor)

XRC Gen 3 control box can be mounted over the drum or over the motor with the included bracket kits. Over-the-motor mounting will provide additional clearance for power wires when mounting the winch close to a grille or winch plate.

Step 1: Locate the control box bracket and hardware (Fig 1).

Step 2: Attach control box bracket to the threaded holes in the top and rear of the winch motor. The top will use the countersunk head bolt along with the bracket spacer. The bracket spacer will be placed on the winch with the flange towards the top. The rear will use the button head bolt and flat washer. Ensure both bolts have been started into the threaded holes before tightening.

Step 3: Loosen the side control box cover bolts just enough to allow them to connect onto the control box bracket (Fig 3).

Step 4: Slide the control box onto the control box bracket by placing the control box cover bolts into the keyway on the control box bracket, slide forward and then tighten bolts.

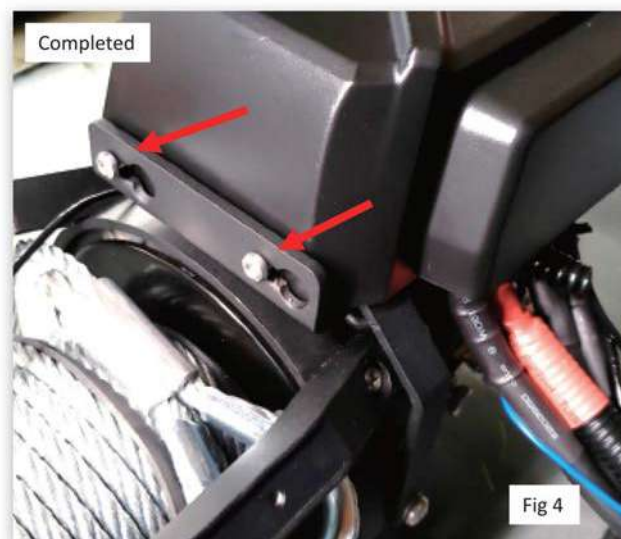
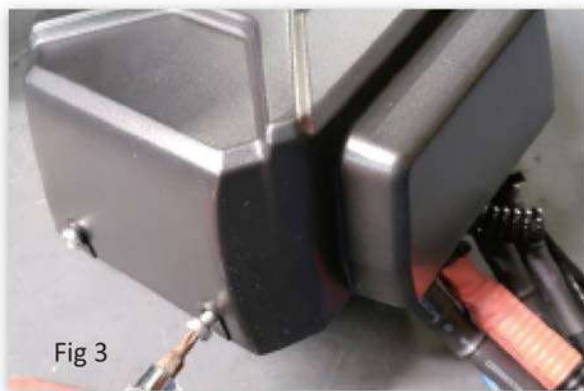
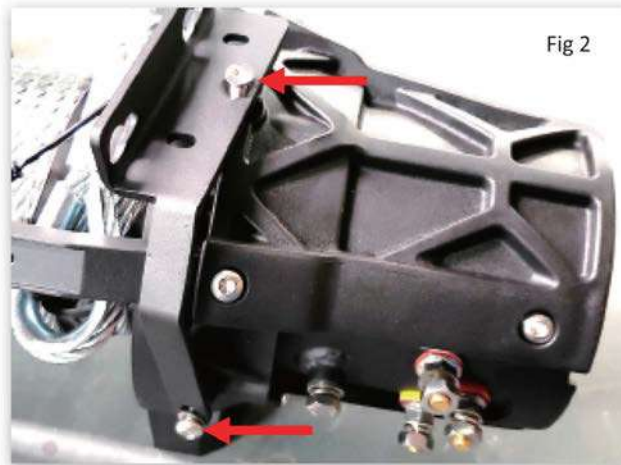

## Wiring for Lighting/DRL and Tie Bar

XRC Gen 3 control box features a light up XRC logo. It is recommended to use as a daytime running light or may be independently switched.

To power XRC logo (Fig 1):

Step 1: Locate blue and white wire coming out of the control box (Fig 2).

Step 2: Decide on power source. This could be an aux switch, daytime running light, fog light, or headlight circuit.

Step 3: Route wire ensuring it will not chafe along any sharp edges or get caught in any moving parts. Then connect to positive power source of your choice.

Note: An inline fuse or wiring to a fused circuit is recommended. XRC logo light draws approximately 50 mAh.

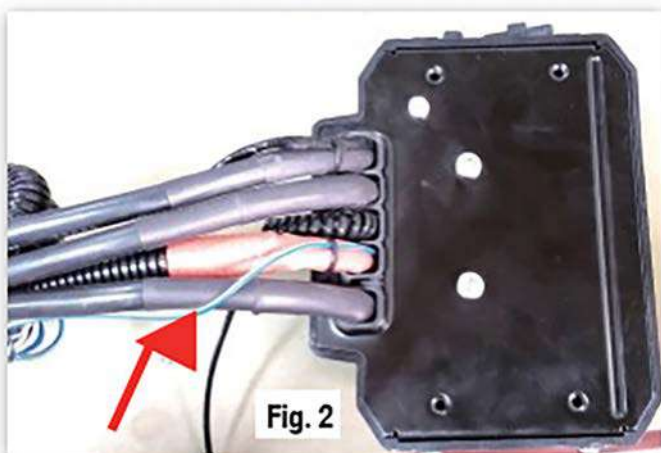

XRC Gen 3 winches feature a lighted front tie bar to light up the winch and drum during evening recoveries. LED tie bar is illuminated only when you have the remote control plugged in to the control box.

Step 1: Locate the black wire coming out of the control box and the black wire coming out of the tie rod on the motor side. Each end of the wire has a small quick connect plug (Fig 3).

Step 2: Locate the arrow on each of the plugs. With the arrows facing each other, connect the quick connect plugs to complete the circuit (Fig 4). DO NOT twist connectors when making the connection.



## Motor Wire Nuts Mounting Supplement

### Motor Wire Nuts Mounting Supplement

Step 1: Do NOT screw wire nuts too tight

Step 2: Put a wrench on bottom nut when installing wire nuts to prevent movement of terminal stud and hold down nut. It's helpful to avoid bolt broken during installation. See pictures below.



Use wrench to prevent movement of bottom lock nut when installing power cables.

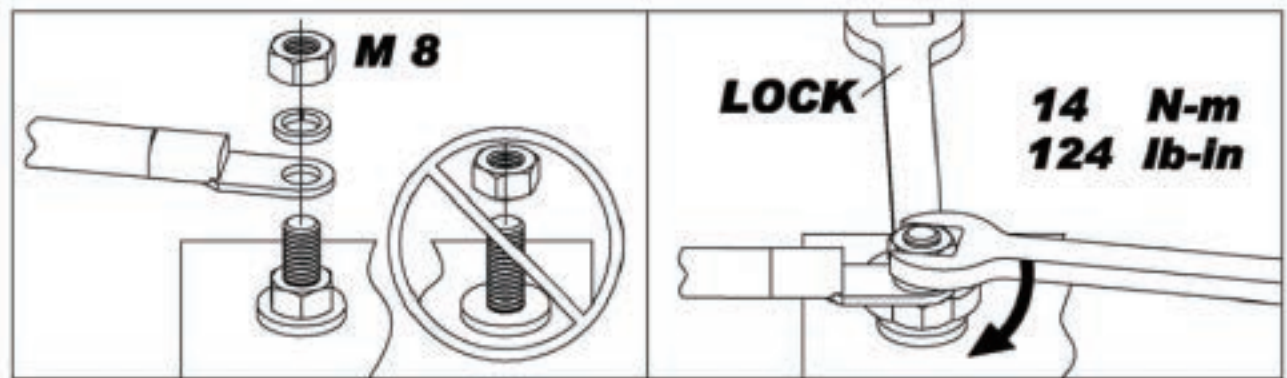



	9500 SPECIFICATIONS	12000 SPECIFICATIONS
Single Rated Line Pull	9,500 lbs (4310 kgs)	12,000 lbs (5443 kgs)
Motor	7HP Series Wound	7HP Series Wound
Controller	12-foot Remote Switch	12-foot Remote Switch
Gear Train	3-Stage Planetary	3-Stage Planetary
Gear Reduction Ratio	173:1	173:1
Clutch	Sliding Ring Gear	Sliding Ring Gear
Braking	Automatic in-The-Drum	Automatic in-The-Drum
Drum Size	Dia. 2.5" (63.5mm) x Length 9.6" (224mm)	Dia. 2.5" (63.5mm) x Length 9.6" (224mm)
Steel Cable	5/16" x 94'(8.0mmx28.5m)	23/64" x 94'(9.2mmx28.5m)
Synthetic Rope (COMP Series)	3/8" x 94'(9.4mmx28m)	7/16" x 90'(11mmx27m)
Fairlead (w/Steel Cable)	4-Way Roller Fairlead	4-Way Roller Fairlead
Fairlead (COMP Series)	Aluminum Hawse Fairlead	Aluminum Hawse Fairlead
Remote Control	Included	Included
Battery	Recommended 650 CCA	Recommended 650 CCA
Battery Leads	25m <sup>2</sup> 72" L (1.83m)	25m <sup>2</sup> 72" L (1.83m)
Net Weight	#97495 87lbs (39.5kgs) / #98495 66lbs (30kgs)	#97612 94lbs (42.5kgs) / #98612 71lbs (32kgs)
Overall Dimensions (L x W x H)	21.7" x 6.7" x 8.3" (546x170x210mm)	21.7" x 6.7" x 8.3" (546x170x210mm)
Mounting Bolt Pattern	10" x 4.5" (254 x 114.3mm)	10" x 4.5" (254 x 114.3mm)

Line Pull - lbs	0	2000	4000	6000	8000	9,500	0	3000	6000	9000	12,000
Line Pull - Kg	0	910	1814	2720	3625	4536	0	1364	2727	4082	5433
Line Speed - Ft/min	27.3	18.3	15.4	12.8	10	7.5	25	14.7	12.8	8	5.2
Line Speed - M/min	10.8	6.30	4.35	3.45	2.90	2.25	7.6	4.5	3.9	2.4	1.6
Motor - AMPS	80	160	220	280	340	385	90	160	230	300	375

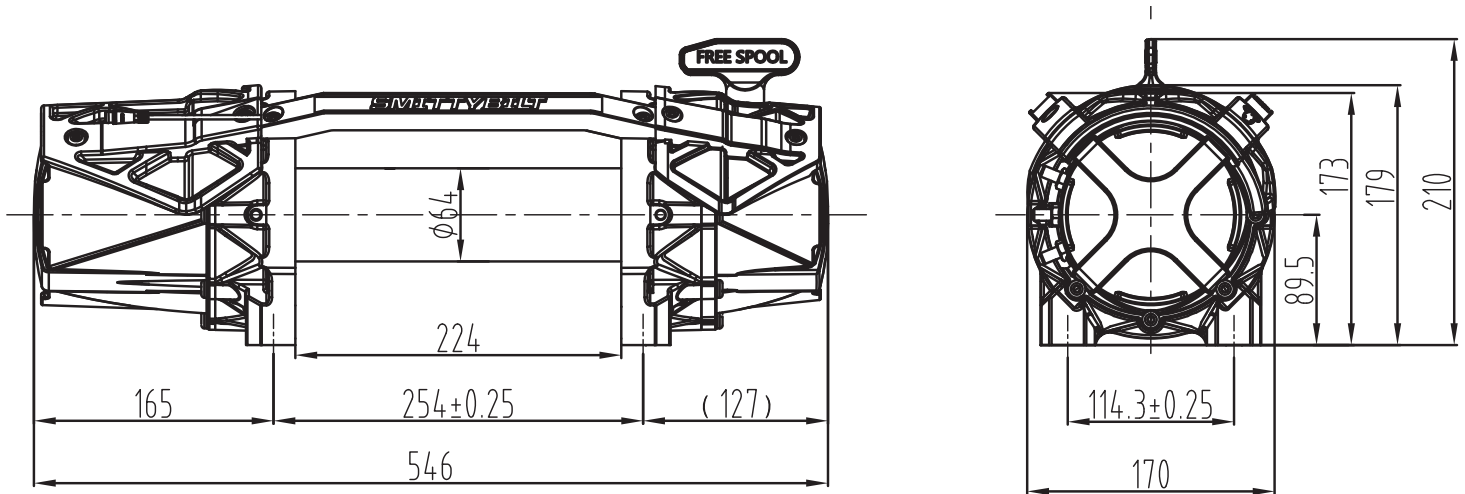

# Understanding IP Ratings

**THE FIRST DIGIT** indicates the level of protection that the enclosure provides against access to hazardous parts (e.g., electrical conductors, moving parts) and the ingress of solid foreign objects.

**THE SECOND DIGIT** indicates protection of the equipment inside the enclosure against harmful ingress of water.



LEVEL	OBJECT SIZE PROTECTED AGAINST	EFFECTIVE AGAINST
0		No protection against contact and ingress of objects
1	>50 mm	Any large surface of the body, such as the back of a hand, but no protection against deliberate contact with a body part
2	>12.5 mm	Fingers or similar objects
3	>2.5mm	Tools, thick wires, etc.
4	>1 mm	Most wires, screws, etc.
5	Dust Protected	Ingress of dust is not entirely prevented, but it must not enter in sufficient quantity to interfere with the satisfactory operation of the equipment; complete protection against contact.
<b>6</b>	<b>Dust Tight</b>	<b>No ingress of dust; complete protection against contact</b>

LEVEL	PROTECTED AGAINST	TESTING FOR	DETAILS
0		Not Protected	
1	Dripping Water	Dripping water (vertically falling drops) shall have no harmful effect.	Test duration: 10 minutes - Water equivalent to 1mm rainfall per minute
2	Dripping Water When Tilted Up To 15°	Vertically dripping water shall have no harmful effect when the enclosure is tilted at an angle up to 15° from its normal position.	Test duration: 10 minutes - Water equivalent to 3mm rainfall per minute
3	Spraying Water	Water falling as a spray at any angle up to 60° from the vertical shall have no harmful effect.	Test duration: 5 min. - Water volume: 0.7 liters per minute - Pressure: 80- 100 kN/m <sup>2</sup>
4	Splashing Water	Water splashing against the enclosure from any direction shall have no harmful effect.	Test duration: 5 min.- Water volume: 10 liters per minute - Pressure: 80- 100 kN/m <sup>2</sup>
5	Water Jets	Water projected by a nozzle (6.3mm) against enclosure from any direction shall have no harmful effects.	Test duration: at least 3 min. - Water volume: 12.5 liters per minute - Pressure: 30 kN/m <sup>2</sup> at distance of 3m
6	Powerful Water Jets	Water projected in powerful jets (12.5mm nozzle) against the enclosure from any direction shall have no harmful effects.	Test duration: at least 3 minutes - Water volume: 100 litres per minute - Pressure:100 kN/m <sup>2</sup> at distance of 3m
<b>7</b>	<b>Immersion Up To 1m</b>	<b>Ingress of water in harmful quantity shall not be possible when the enclosure is immersed in water under defined conditions of pressure and time (up to 1m of submersion).</b>	<b>Test duration: 30 minutes Immersion at depth of 1m</b>
8	Immersion Beyond 1m	The equipment is suitable for continuous immersion in water under conditions which shall be specified by the manufacturer. Normally, this will mean that the equipment is hermetically sealed. However, with certain types of equipment, it can mean that the water can enter but only in such a manner that it produces no harmful effects.	Test duration: continuous ummersion in water.

WINCH	PART NO.	DESCRIPTION	CONTAINS
XRC Gen3 9.5K	97695-57	7.0 hp motor asm 9.5K Winch	9.5k complete Motor assembly, motor side casting seal to drum
XRC Gen3 9.5K	97695-41	Cable	9.5k Appropriate cable and securing screw
XRC Gen3 9.5K/12k	97695-46	Hook	9.5K/12K hook, flag, pin, clip
XRC Gen3 9.5K/12k	97695-37	Free spool handle	9.5K/12K Handle, seal, and hardware
XRC Gen3 9.5K/12k	97695-42	Rope fix bolt	9.5K/12K
XRC Gen3 9.5K	97695-55	9.5K gearbox asm	9.5k complete gear box
XRC Gen3 9.5K/12k	97695-47	Roller Fairlead	9.5K/12K with hardware
XRC Gen3 9.5K/12k	97695-77	Hawse Fairlead	9.5K/12K with hardware
XRC Gen3 9.5K/12k	97695-53	Control box cover	9.5K/12K
XRC Gen3 9.5K/12k	97695-58	Socket covers	9.5K/12K remote and 12v socket covers
XRC Gen3 9.5K/12k	97695-79	Armor set	9.5K/12K Both side armors and hardware
XRC Gen3 9.5K/12k	97695-50	Wired remote with LI	9.5K/12K Wired remote and cord

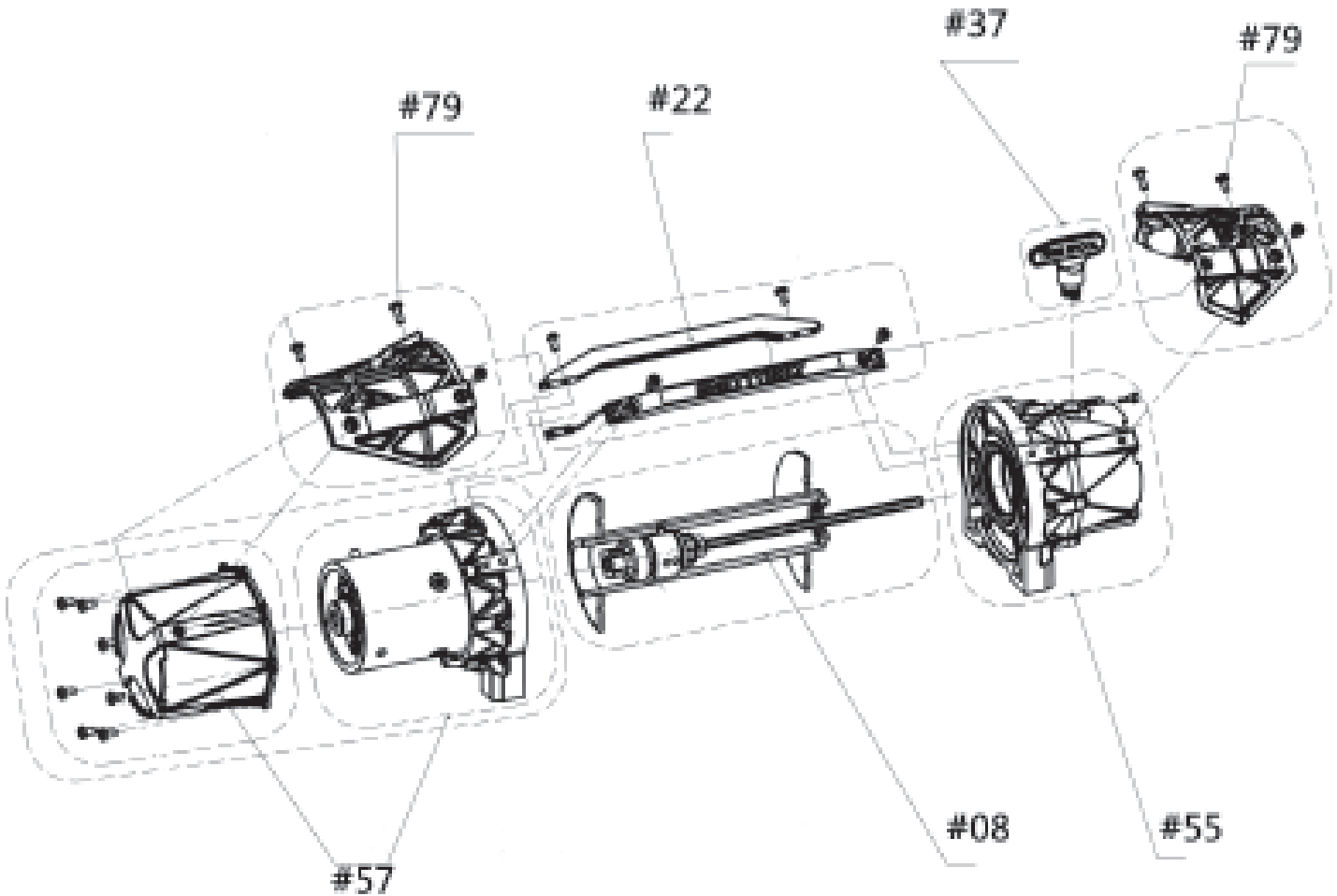

WINCH	PART NO.	DESCRIPTION	CONTAINS
XRC Gen3 9.5K/12k	97695-52	Contactora with LED asm	9.5K/12K ISM assembly
XRC Gen3 9.5K/12k	97695-22	Crossbars	9.5K/12K Both crossbars with LED as in production and bolts
XRC Gen3 9.5K/12k	97695-08	Drum	9.5K/12K Spool and cable-securing screw, brake assembly and cross shaft
XRC Gen3 9.5K/12k	97695-43	Hardware	9.5K/12K Mounting hardware for installing the winch to the mount
XRC Gen3 9.5K	97695-78	Rope	9.5k Appropriate rope and securing screw
XRC Gen312k	97612-57	7.0 hp motor asm12k Winch	12k complete Motor assembly, motor side casting seal to drum
XRC Gen312k	97612-55	12000 gearbox asm	12k complete Gearbox with gears, side casting, seal to drum
XRC Gen312k	97612-78	Rope	12k Appropriate rope and securing screw
XRC Gen312k	97612-41	Cable	12k Appropriate cable and securing screw
XRC Gen3 9.5K/12k	97695-49	Complete Control Box Assembly	9.5K/12K complete control box assembly
XRC Gen3 9.5K/12k	97695-56	Control Box Cover	9.5K/12K control box cover with socket, socket dust cover and LED logo
XRC Gen3 9.5K/12k	97695-59	Remote Control Socket	9.5K/12K complete socket connector assembly with screws

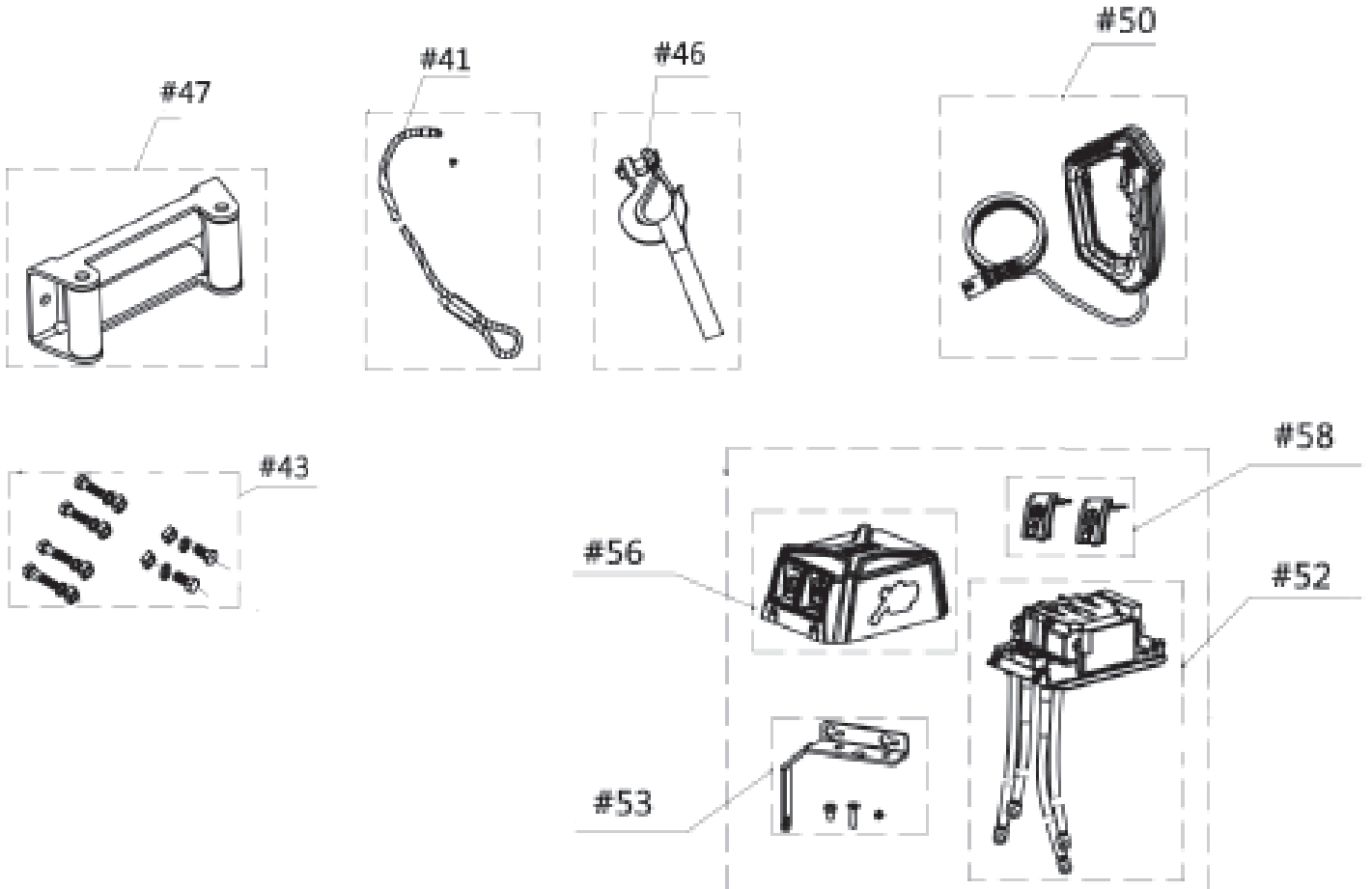





## Troubleshooting

	POSSIBLE CAUSE	SUGGESTED REMEDY
Motor does not turn on	Safety switch is off	Turn safety switch to ON position
	Switch assembly not connected properly	Insert switch assembly firmly to the connector
	Loose battery cable	Tighten nuts on cable connectors
	Solenoid malfunctioning	Tap solenoid to free contact, applying 12 volts to coil terminal directly. The solenoid will make an audible clicking sound when activating.
	Defective switch assembly	Replace switch assembly
	Defective motor	Check for voltage at armature port with switch pressed. If voltage is present, replace motor.
	Water has entered motor	Check for voltage at armature port with switch pressed. If voltage is present, replace motor.
Motor runs hot	Long period of operation	Let winch cool down periodically.
Motor runs slowly or without normal power	Low battery	Recharge battery by running vehicle
	Insufficient current or voltage	Clean, tighten or replace the connector.
Motor runs but cable drum does not turn	Clutch not engaged	Turn clutch into IN position, if that does not work, ask a qualified technician to check and repair.
Motor runs in one direction only	Defective or stuck solenoid	Tap solenoid to free contacts. Repair or replace solenoid.



Check out the collection of winches and accessories we offer.