



Installation Instructions

SRC Classic Rear Bumper (#76750)
1987-2006 Jeep Wranglers

NOTE: Carefully read entire instructions thoroughly before attempting to assemble and/or install this product.

Parts Included	Qty
Rear Bumper	1
Backing Plates	4
3/8" x 1 1/4" Hex Bolts	8
3/8" Flat Washers	8
3/8" Lock Washers	8
7/16" x 1 1/4" Hex Bolts	2
7/16" Flat Washers	2
7/16" Lock Washers	2

Note: Actual hardware may be Metric, which would coincide with the standard size shown.

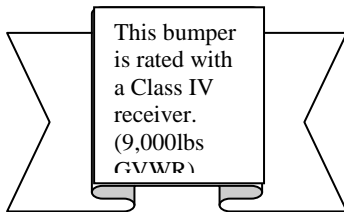

Note: Check with OEM towing specifications and operation before towing anything with your vehicle.

Installation Instructions

1. Remove factory bumper, if equipped.
2. Locate (2) Backing Plates, (4) 3/8" Hex Bolts, (4) 3/8" Flat Washers, and (4) 3/8" Lock Washers. With a helpers assistance attach backing plates to the rear of the vehicle frame. Align holes in rear plate on the Bumper to those existing holes in the frame. Loosely attach to one side of vehicle with the hardware listed in this step. (See illustration below)
3. Repeat Step 2 for opposite side; loosely attach bolts at this time.
4. Align the lower mount brackets (one per side) with the holes on the bottom of the frame. Using (1) 7/16" Hex Bolt, (1) 7/16" Flat Washer, and (1) 7/16" Lock Washer attach and secure the bottom bracket to the frame. **Note:** if equipped, the factory bolt can be used in this step.
5. Repeat Step 4 for opposite side.



Installation Instructions
SRC Classic Rear Bumper (#76750)
1987-2006 Jeep Wranglers

6. Tighten all hardware completely at this time.

Note: On 97-on models, dropping of the fuel tank and skid plate will ease installation. Be sure to check and follow manufacturer's directions for this process.

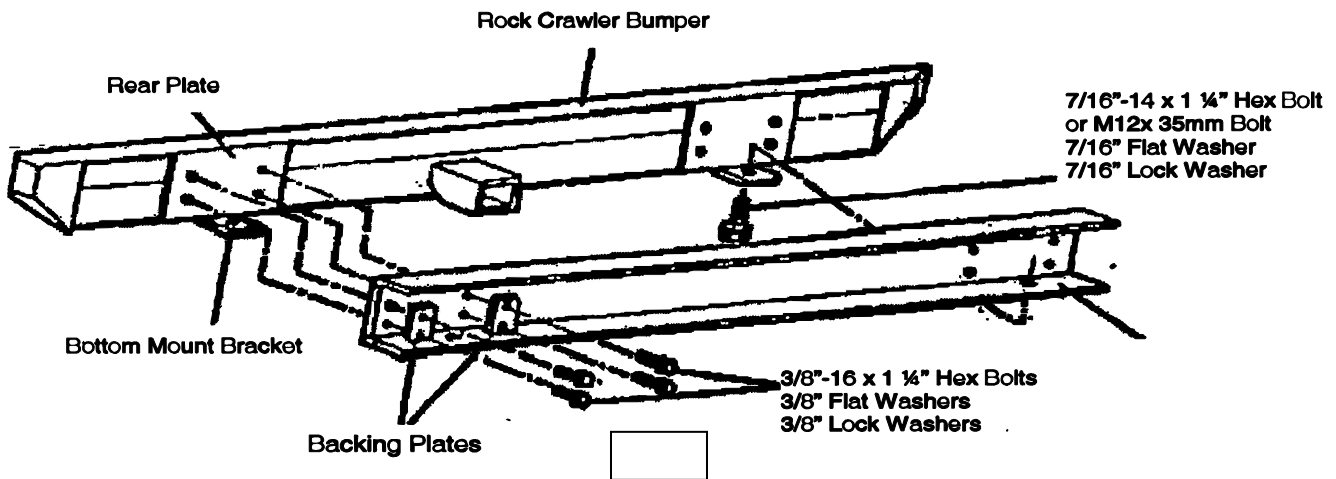

NOTE: To protect your investment, wax this product after installing. Regular waxing is recommended. Do not use any type of polish/wax that contains abrasives that could damage the finish.