

SMARTCAP™

EVO, EVOa, EVOc & EVOd Series

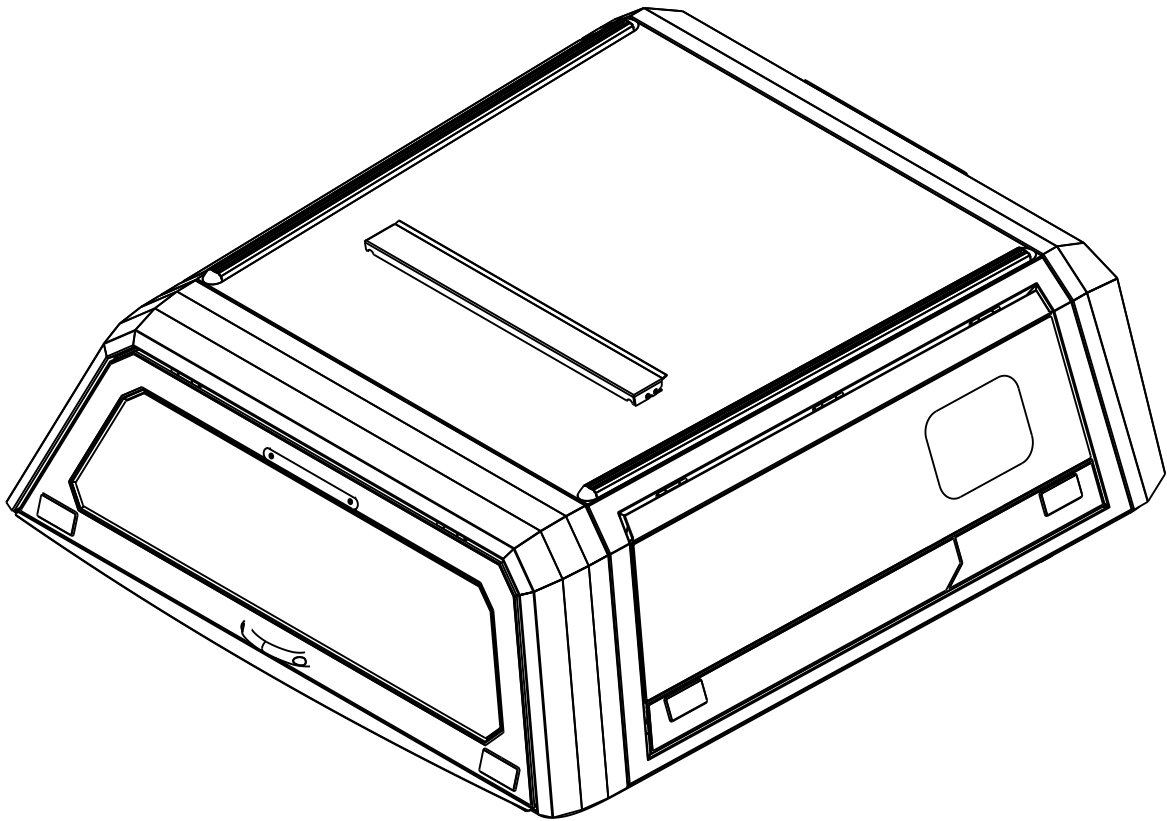
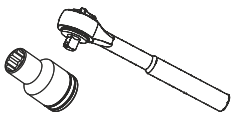

TABLE OF CONTENTS

REQUIRED TOOLS	2
ASSEMBLY INSTRUCTIONS	3
Unboxing Instructions	3
Components & Assembly Hardware	4
Assembly of the SmartCap	6
INSTALLATION INSTRUCTIONS	13
Fitment Kit Contents	13
Installation of the SmartCap	14
GM Silverado, GM Colorado, Jeep Gladiator (Without Trail Rail), Dodge Ram, Ford F-Series	15
Jeep Gladiator (With Trail Rail)	16
Ford Ranger	17
Toyota Tacoma	20
THIRD BRAKE LIGHT WIRING HARNESS	21
GM Silverado, GM Colorado, Dodge Ram, Ford F-Series, Ford Ranger, Toyota Tundra	21
Wiring Reference Guide	22
For Vehicles With a Factory 7 Way	23
For Vehicles Without a Factory 7 Way	24
Toyota Tacoma	25
Wiring Reference Guide	26
Wiring Reference Guide	27

REQUIRED TOOLS



Socket Wrench
10mm & 13mm Socket

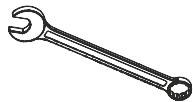

Combination Wrench
10mm & 13mm Flat

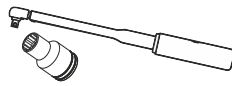

Torque Wrench
10mm & 13mm Flat



Sharp Box Knife
Or Scissors

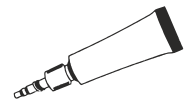

Super Glue

WARNING



- **USE ONLY THE TOOLS RECOMMENDED IN THIS GUIDE**
- **USE ONLY THE HARDWARE THAT HAS BEEN PROVIDED**
- **HANDLE ALL COMPONENTS WITH CARE**
- **IT IS RECOMMENDED THAT FOUR PEOPLE LIFT/LOWER THE SMARTCAP**
- **NEVER USE ACETONE ON THE PAINTWORK**
- **AVOID PINCHING/SQUASHING HANDS**

UNBOXING INSTRUCTIONS

1. INSPECT THE ENTIRE PACKAGE FOR DAMAGE. IF ANY IS FOUND, CONTACT: SUPPORT.NA@RSISMARTCAP.COM
2. ENSURE THE WORK AREA IS CLEAN BEFORE UNBOXING.
3. ENSURE THE REQUIRED TOOLS ARE PRESENT AND ALL HARDWARE CONTENTS ARE ACCOUNTED FOR.
4. WE RECOMMEND A MINIMUM OF 2 PEOPLE TO UNBOX THE PACKAGED CONTENT.
5. UNSTRAP THE BOXES.
6. ORIENT THE ROOF PANEL BOX WITH THE "THIS SIDE UP" LABEL FACING UPWARDS.

NOTE: ENSURE ALL PANELS ARE CORRECTLY ORIENTATED (THIS SIDE UP). USE STRAPS TO HELP LIFT THE BOXES

UNBOXING EXPLODED VIEW

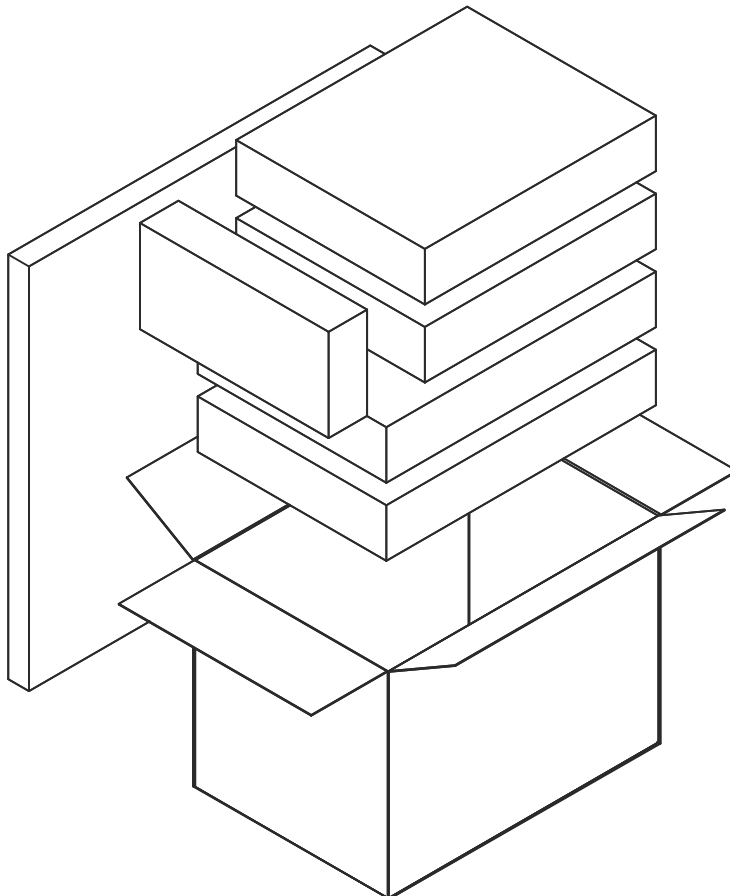

COMPONENTS

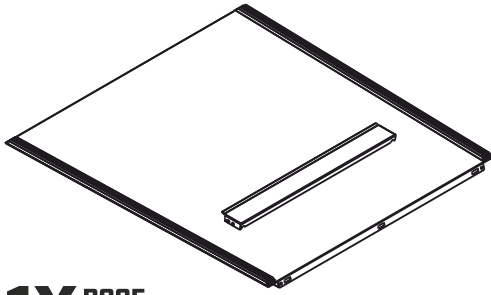

1X ROOF
PANEL

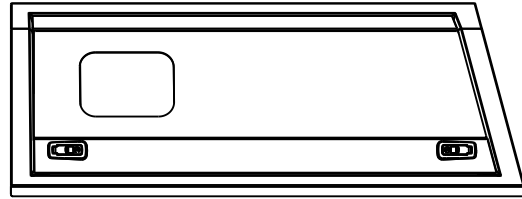

2X SIDE PANELS
LEFT & RIGHT

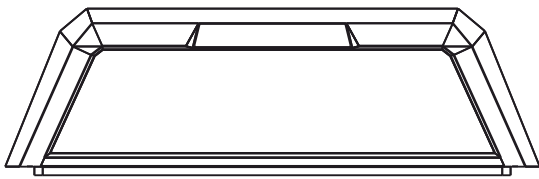

1X FRONT
FLANGE

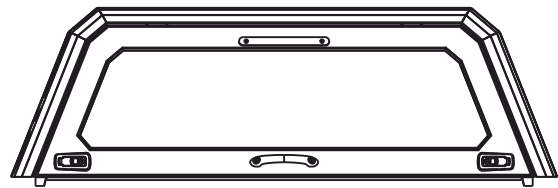

1X REAR
FLANGE

ASSEMBLY HARDWARE

**SMARTCAP ASSEMBLY HARDWARE THAT IS ALREADY
HAND FASTENED TO THE FLANGES**

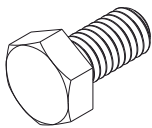

28X SET SCREW
M6X10

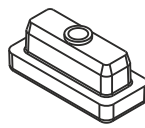

28X FASTENER
BLOCKS

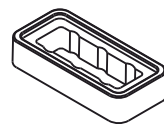

28X FASTENER BLOCK
CLAMP

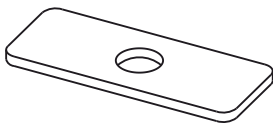

28X FASTENER BLOCK
LOADSPREADER

ASSEMBLY KIT CONTENTS

KIT 1: ROOF PANEL FASTENING HARDWARE

**FOR ALL SB
SHORT BED**



**10X M6
NYLOC NUTS**

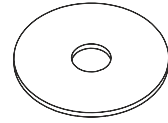

**10X M6X25
FENDER WASHERS**

**FOR ALL ST
STANDARD BED**



**12X M6
NYLOC NUTS**

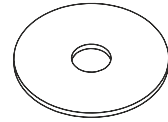

**12X M6X25
FENDER WASHERS**

KIT 2: SPARE PARTS

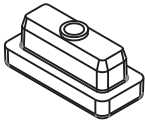

**1X FASTENER
BLOCKS**

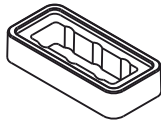

**1X FASTENER BLOCK
CLAMP**

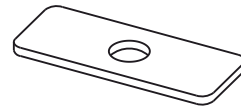

**1X FASTENER BLOCK
LOADSPREADER**

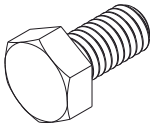

**1X SET SCREW
M6X10**



**1X M6
NYLOC NUTS**

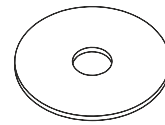

**1X M6X25
FENDER WASHERS**

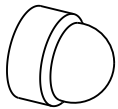

**4X M6
NUT CAP**

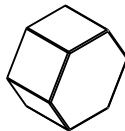

**4X M6
HEX CAP**

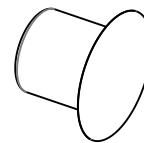

**4X BARREL
PLUG**

WEATHER SEAL



**1X D-RUBBER
WEATHER STRIP**

ASSEMBLY OF THE SMARTCAP

ASSEMBLY EXPLODED VIEW

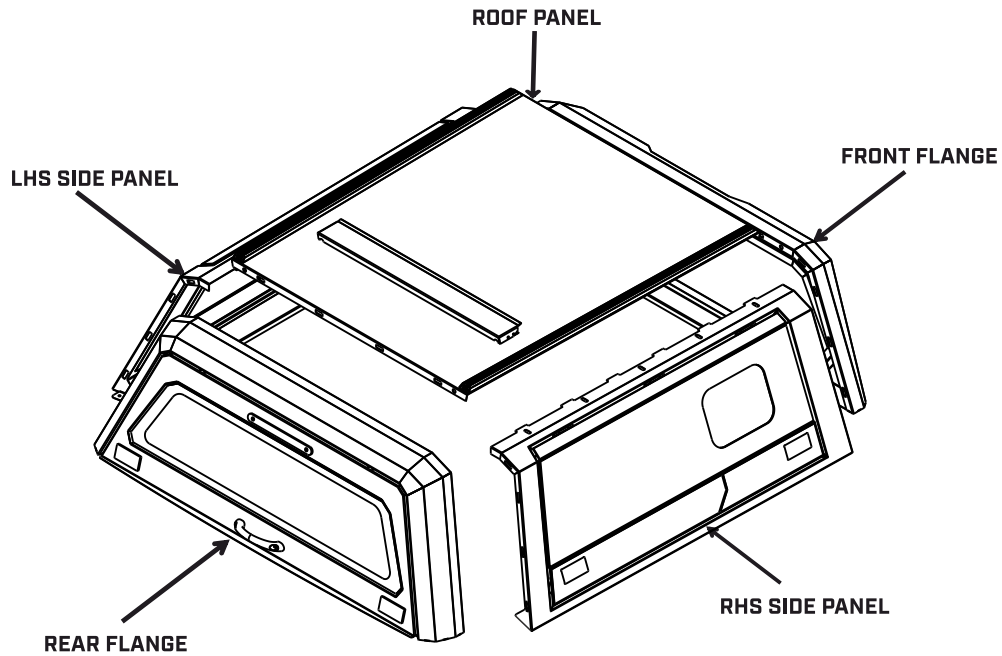

STEP ONE

1. ORIENT THE ROOF PANEL BOX WITH "THIS SIDE UP" LABEL FACING UPWARDS, THEN OPEN.
2. UNFOLD THE PROTECTIVE PLASTIC SHEET, LEAVING IT ON THE BOTTOM OF THE ROOF PANEL.
3. USE THE OPEN BOX LID AS A PROTECTIVE SURFACE TO ASSEMBLE THE SMARTCAP UPON.
[SEE FIGURE 1]
4. WORK WITH CAUTION TO PREVENT ANY DAMAGE.

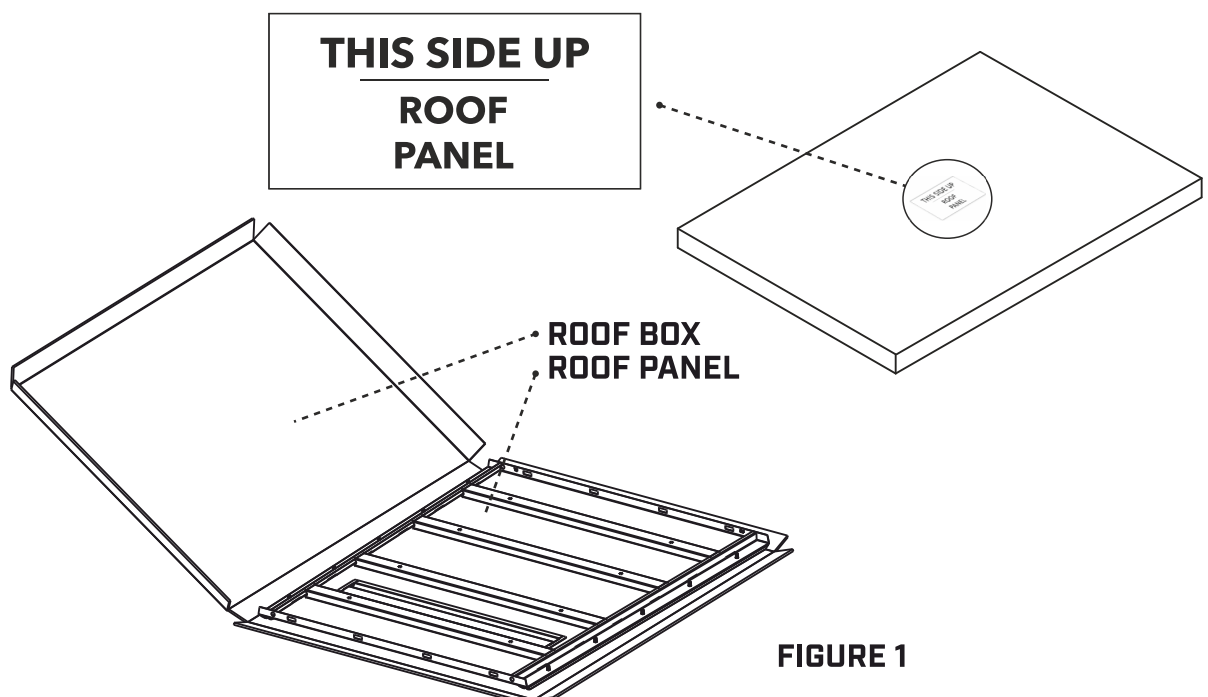

FIGURE 1

ASSEMBLY OF THE SMARTCAP

STEP TWO



1. REMOVE THE LEFT SIDE PANEL FROM ITS PACKAGING AND PROTECTIVE PLASTIC BAG.
2. YOU WILL NOTICE ONE END OF THE PANEL IS SLANTED. TO ENSURE IT'S CORRECTLY ORIENTATED, PLACE THE SLANTED END TOWARDS THE AIR-VENT ON THE ROOF PANEL.
3. ONCE ORIENTATED CORRECTLY, INSERT THE SIDE PANEL INTO THE ROOF. (SEE FIGURE 2)
4. TO ALLOW GREATER FLEXIBILITY FOR PANEL FITMENT, ONLY HAND TIGHTEN HARDWARE AT THIS STAGE. (SEE FIGURE 3)
5. WORK WITH CAUTION TO PREVENT ANY DAMAGE.

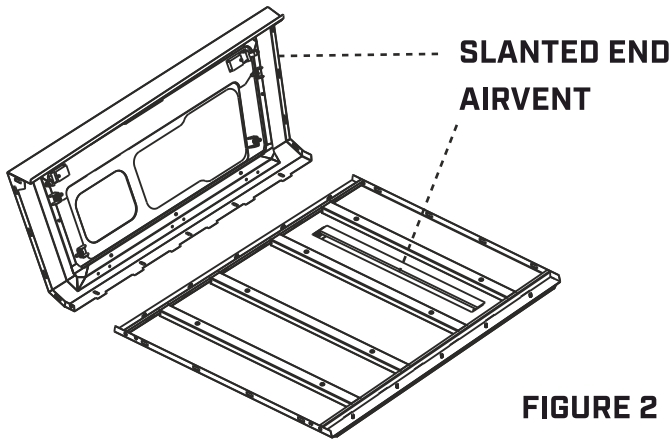

HOOK THE SIDE PANEL INTO THE ROOF, CORRECTLY ORIENTATED, SLANTED END OF SIDE PANEL TO FACE THE DIRECTION OF THE ROOF AIR-VENT.

FIGURE 2

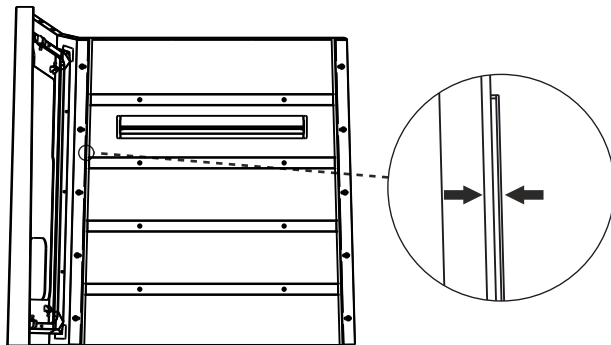

GENTLY TAP THE SIDE PANEL INTO PLACE, ENSURING THE GAP BETWEEN THE SIDE PANEL AND ROOF IS MINIMAL.

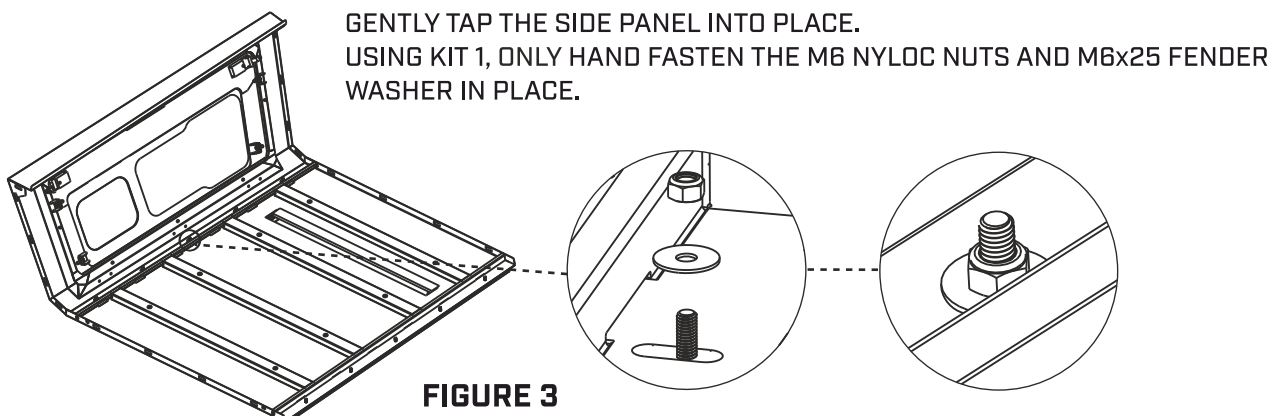

FIGURE 3

ASSEMBLY OF THE SMARTCAP

STEP THREE



1. REMOVE THE RIGHT HAND SIDE PANEL FROM ITS PACKAGING AND PROTECTIVE PLASTIC BAG.
2. HOOK THE SIDE PANEL INTO THE ROOF. [SEE FIGURE 4]
3. HAND FASTEN THE HARDWARE IN PLACE. [SEE FIGURE 5]
4. WORK WITH CAUTION TO PREVENT ANY DAMAGE.

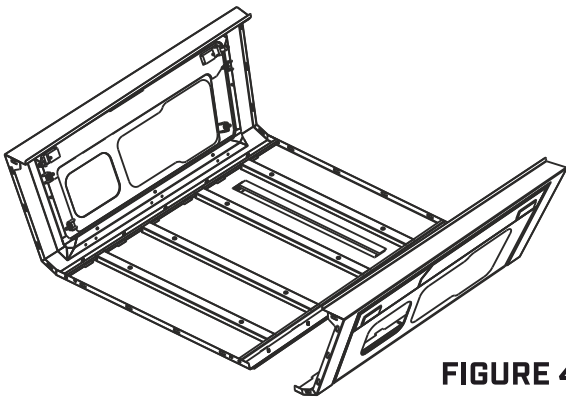
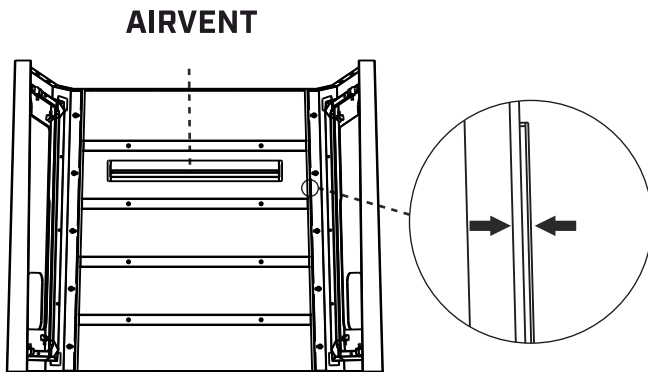
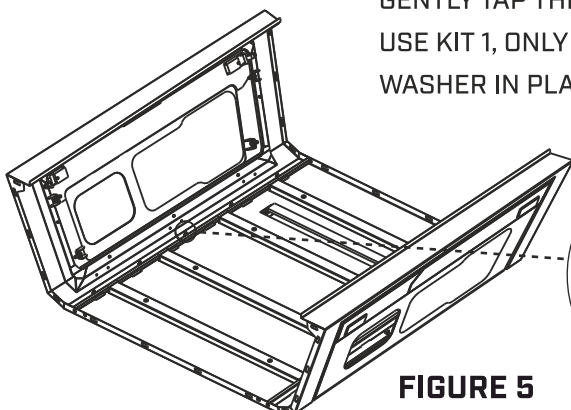

FIGURE 4

HOOK THE SIDE PANEL INTO THE ROOF. CORRECTLY ORIENTATED, SLANTED END OF THE SIDE PANEL TO FACE THE DIRECTION OF THE ROOF AIR-VENT.



GENTLY TAP THE SIDE PANEL INTO PLACE, ENSURING THE GAP BETWEEN THE SIDE PANEL AND ROOF IS MINIMAL.



GENTLY TAP THE SIDE PANEL INTO PLACE. USE KIT 1, ONLY HAND FASTEN THE M6 NYLOC NUTS AND M6x25 FENDER WASHER IN PLACE.

FIGURE 5

ASSEMBLY OF THE SMARTCAP

STEP FOUR

1. REMOVE HAND FASTENED CLIPS ON FRONT FLANGE TO RE-USE IN ASSEMBLY PROCESS.
2. START TO HAND FASTEN THE FRONT FLANGE IN THE CENTER AND ENSURE THE PANELS ARE FLUSH WITH ONE ANOTHER AT EACH POINT OF FASTENING.
3. FOLLOW THE FASTENING SEQUENCE BELOW. (SEE FIGURE 6)

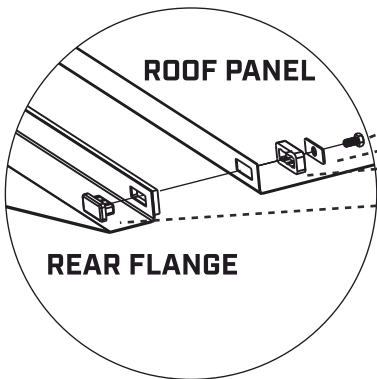

- M6 x 10 SET SCREW
- LOADSPREADER PLATE
- FASTENER CLAMP
- FASTENER CLIP

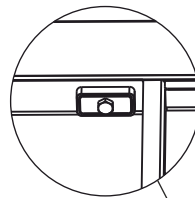

FACE BOLTS INWARD AS THIS WILL MAKE FASTENING EASIER.

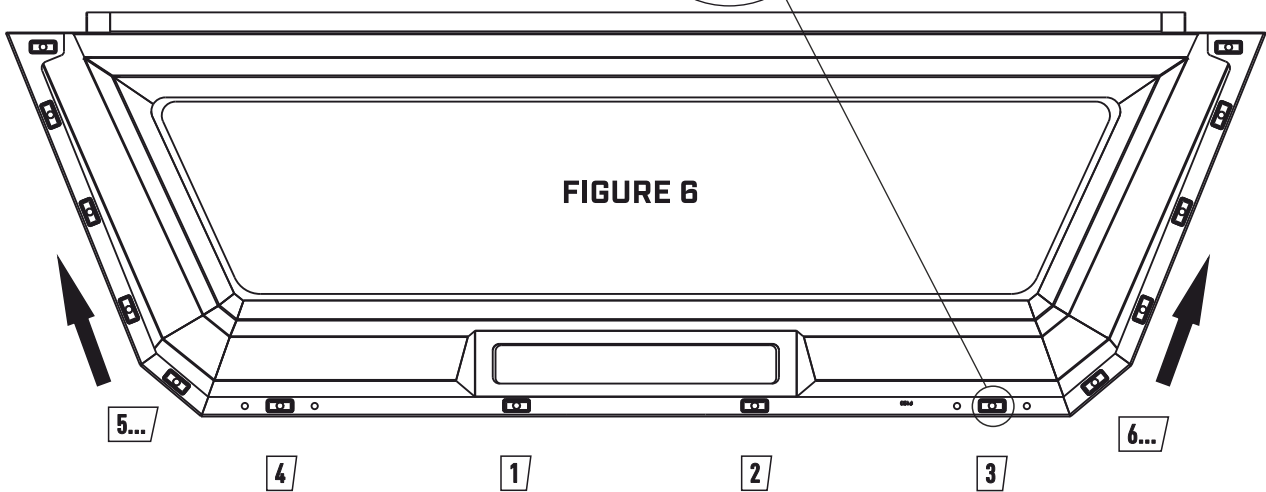

ENSURE THE FRONT FLANGE IS FLUSH WITH THE SIDE PANEL.

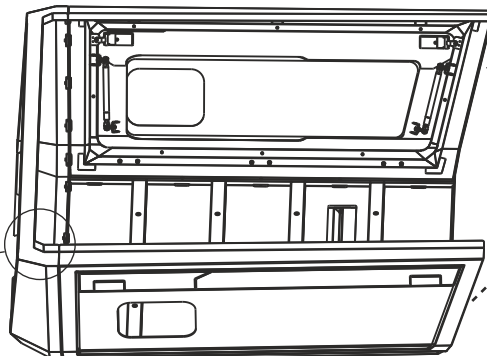
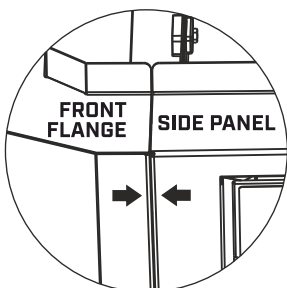

SUPPORT SIDE PANEL TO HELP ALIGN THE FLANGE, WHEN INSERTING THE FASTENER CLIPS.

ASSEMBLY OF THE SMARTCAP

STEP FIVE

1. REMOVE HAND FASTENED CLIPS ON REAR FLANGE TO RE-USE IN ASSEMBLY PROCESS.
2. START TO HAND FASTEN THE REAR FLANGE IN THE CENTER AND ENSURE THE PANELS ARE FLUSH WITH ONE ANOTHER AT EACH POINT OF FASTENING.
3. FOLLOW THE FASTENING SEQUENCE BELOW. (SEE FIGURE 7)

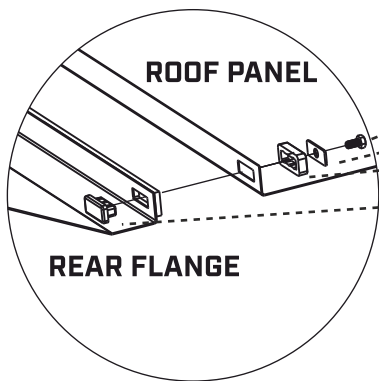

- M6 x 10 SET SCREW
- LOADSPREADER PLATE
- FASTENER CLAMP
- FASTENER CLIP

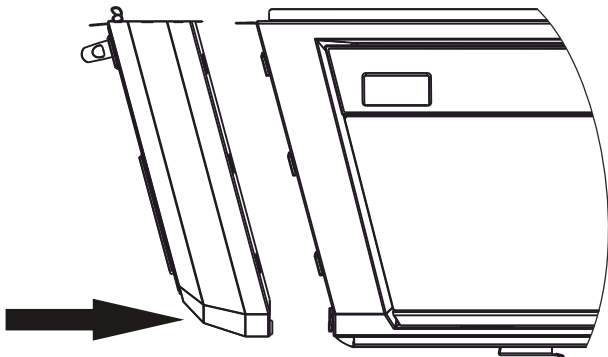

PUSH GENTLY WITH FOOT TO HELP STABILIZE THE FLANGE AND MAKE HAND TIGHTENING OF THE BOLTS EASIER.

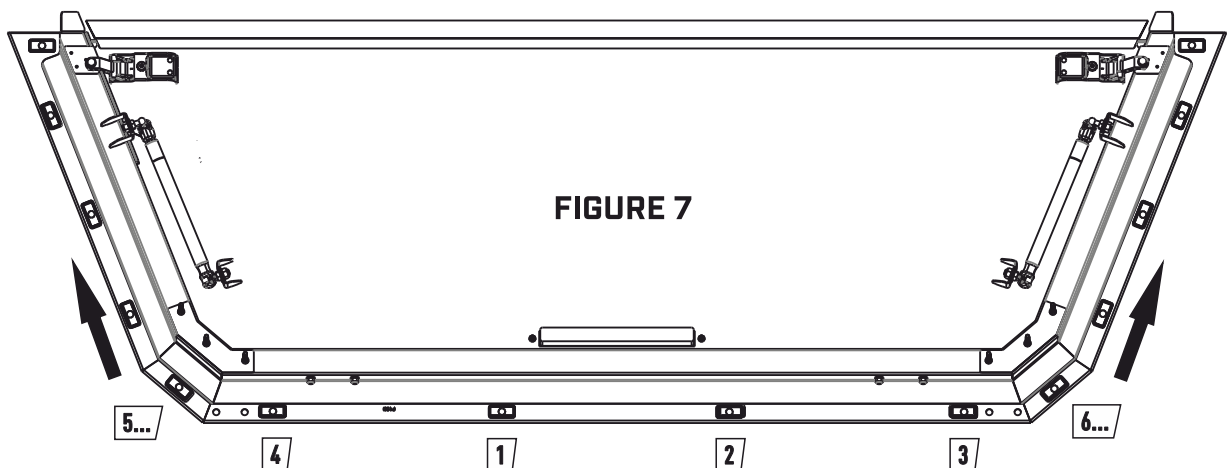

ASSEMBLY OF THE SMARTCAP

STEP SIX

1. ONCE THE SMARTCAP IS FULLY ASSEMBLED AND HAND TIGHTENED, PROCEED TO TORQUE THE FRONT AND REAR FLANGE FASTENERS 6.6 FT-LB, 79 IN-LB OR 9 NM.
2. PROCEED TO TORQUE THE M6 NYLOC NUTS WHICH WERE PREVIOUSLY HAND FASTENED TO THE ROOF, IN STEPS 2 & 3 (SEE FIGURE 8) 4.4 FT-LB, 53 IN-LB OR 6 NM.



FIGURE 8

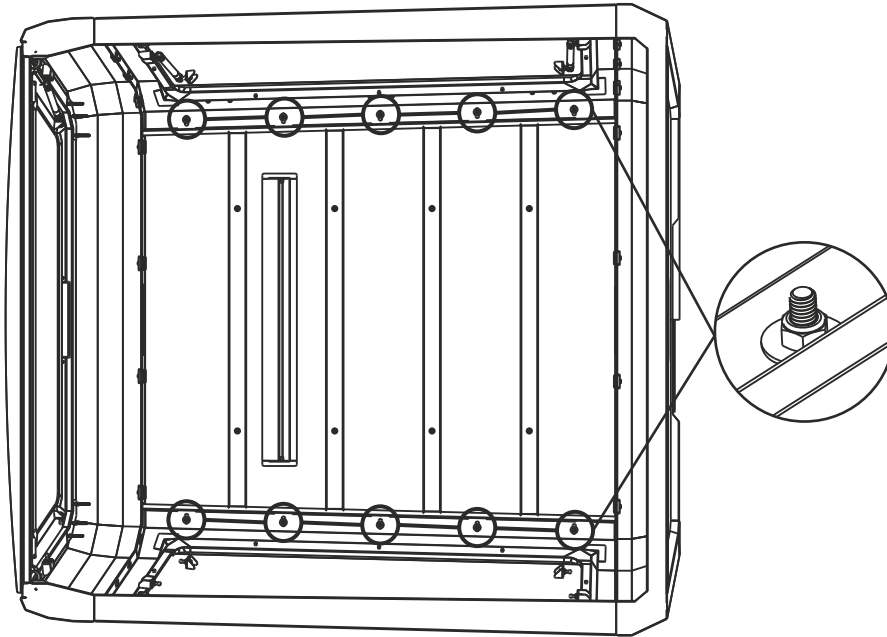

STEP SEVEN

1. ONCE ALL HARDWARE IS TIGHTENED SUFFICIENTLY, PROCEED TO APPLY THE BOTTOM D - RUBBER / WEATHER STRIP.
2. REMOVE THE BACKING TAPE ON THE ADHESIVE STRIP SLOWLY AS YOU BOND THE RUBBER DOWN CAREFULLY.
3. APPLY THE D - RUBBER, STARTING ON THE RIGHT HAND SIDE OF THE REAR FLANGE. (SEE FIGURE 9, ON PAGE 12)



REMOVE GRADUALLY AS YOU CAREFULLY BOND DOWN THE WEATHER SEAL STRIP.

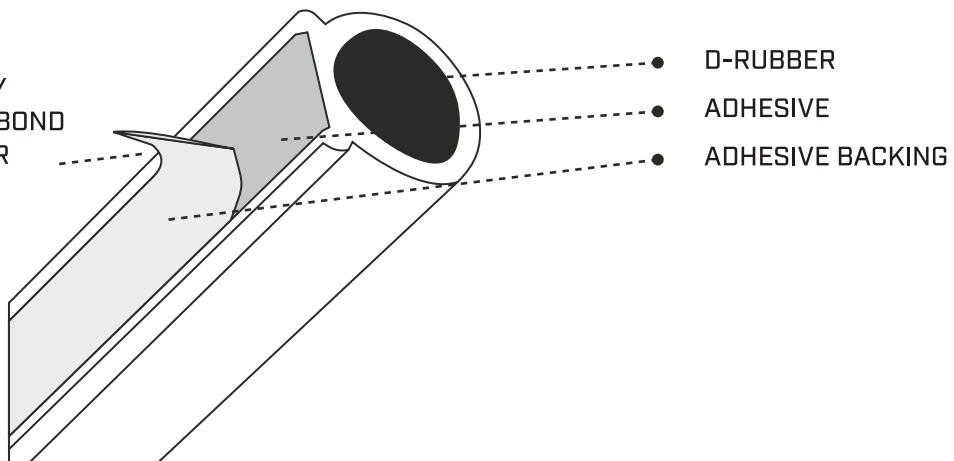

ASSEMBLY OF THE SMARTCAP

FOLLOW BOTTOM EDGE OF SMARTCAP
FIGURE 9

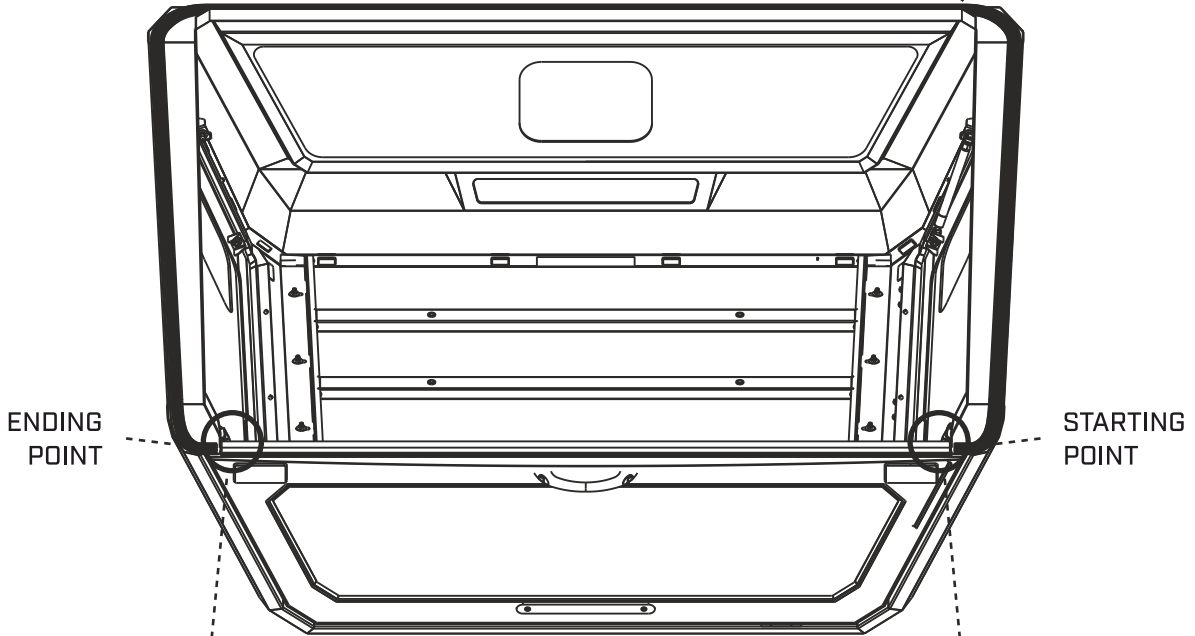

CUT STRAIGHT TO END OF FOOTPLATE.
ENSURE IT IS A CLEAN STRAIGHT
CUT WITH A SHARP
BOX KNIFE OR
SCISSORS.

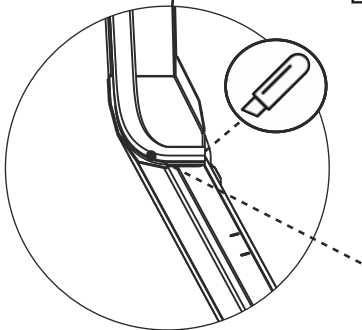

APPLY TO END OF
FLANGE FOOT PLATE.

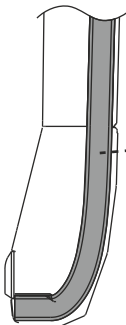
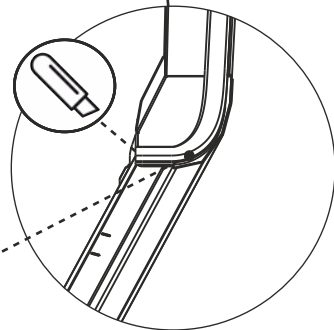

PLEASE NOTE:
APPLY D-RUBBER WEATHER STRIP
AROUND BASE OF SMARTCAP.
APPROXIMATELY 1/8" FROM THE EDGE.

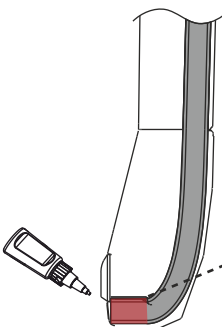

PLEASE NOTE:
FOR BEST RESULTS, BOND THE ENDS
OF THE D RUBBER WEATHER STRIP
DOWN WITH SUPER GLUE.

INSTALLATION COMPONENTS

FITMENT KIT CONTENT (HARDWARE)

GM SILVERADO
GM COLORADO
JEEP GLADIATOR
DODGE RAM
FORD F150
FORD F250
TOYOTA TUNDRA

[PG.15]

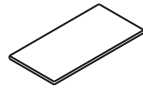

6X THIN RUBBER PAD

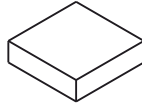

8X THICK RUBBER PAD



1X 5MM X 30MM FOAM SEAL TAPE

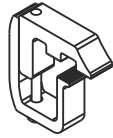

6X CLAMPS
FORD F150 & F250
GM SILVERADO
GM COLORADO
DODGE RAM
TOYOTA TUNDRA

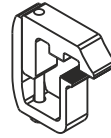

6X CLAMPS
JEEP GLADIATOR
WITHOUT TRAIL RAIL

JEEP GLADIATOR
WITH TRAIL RAIL

[PG.16]

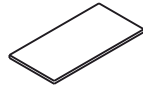

6X THIN RUBBER PAD

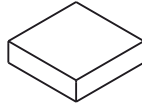

8X THICK RUBBER PAD



1X 5MM X 30MM FOAM SEAL TAPE



6X CLAMPS
JEEP GLADIATOR

FORD RANGER

[PG.17]

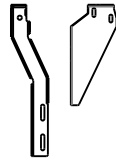

4X BRACKETS
FORD RANGER

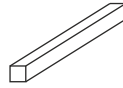

1X 20MM X 20MM FOAM SEAL TAPE

TOYOTA TACOMA

[PG.23]

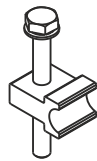

6X CLAMPS
TOYOTA TACOMA

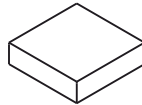

8X THICK RUBBER PAD



1X 5MM X 30MM FOAM SEAL TAPE

INSTALLATION OF THE SMARTCAP

STEP ONE



1. SOME TRUCK BEDS MAY HAVE HEIGHT DIFFERENCES BETWEEN THE SIDES AND FRONT OF THE TRUCK BED. IF THAT IS THE CASE WITH YOUR TRUCK BED, APPLY A FOAM STRIP TO THE LIP OF THE FRONT PANEL.
2. REMOVE THE ADHESIVE BACKING TAPE FROM THE FOAM STRIP. [SEE FIGURE 1 & 2]
3. APPLY FOAM STRIP ON THE FRONT LIP OF THE PICK UP BOX TO ACCOUNT FOR ANY HEIGHT DIFFERENCES BETWEEN THE PICKUP BOX SIDES AND THE FRONT PICKUP BOX PANEL. [SEE FIGURE 2]
4. CUT TO LENGTH [SEE FIGURE 3]

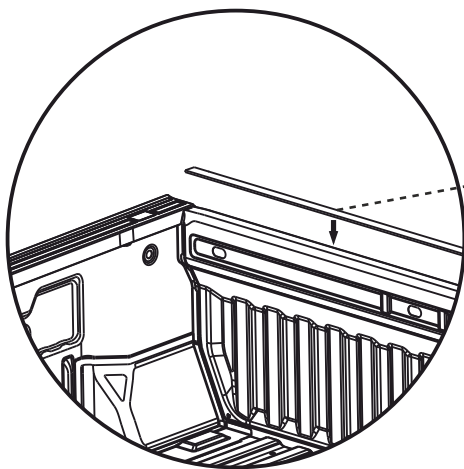
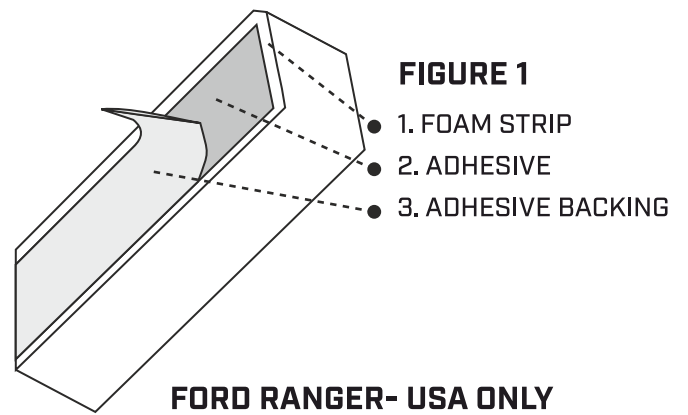
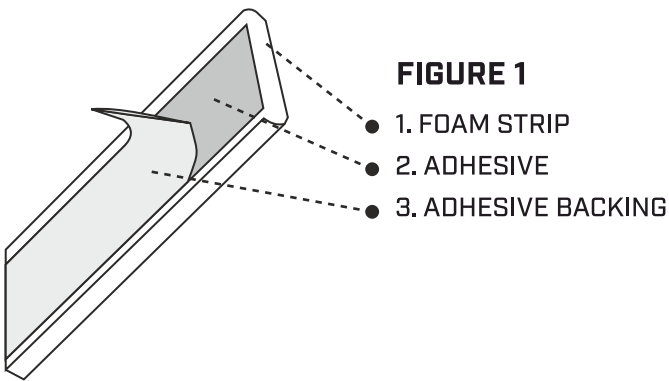

FIGURE 2
FOAM STRIP
FRONT PICKUP BOX PANEL

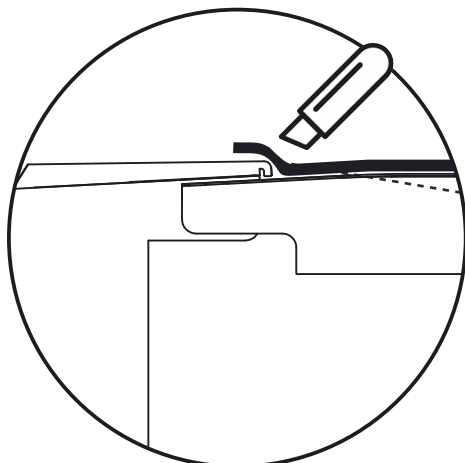

FIGURE 3
FOAM STRIP
TRIM EXCESS FOAM STRIP

INSTALLATION OF THE SMARTCAP

GM SILVERADO - GM COLORADO - JEEP GLADIATOR - DODGE RAM - FORD F-SERIES
TOYOTA TUNDRA

STEP ONE



1. A MINIMUM OF FOUR PEOPLE ARE RECOMMENDED TO PICK UP AND PLACE THE SMARTCAP ONTO THE TRUCK.
2. TO KEEP FROM DAMAGING YOUR D-RUBBER DURING THE INSTALLATION PROCESS, IT IS IMPORTANT YOU LIFT THE SMARTCAP IN PLACE AND DO NOT DRAG IT ACROSS THE TRUCK BED RAILS.
3. ONCE THE SMARTCAP IS CENTERED, PLACE CLAMPS IN POSITION. (SEE FIGURE 3)
4. PLACE THE SUPPLIED THIN RUBBER PAD ON THE SIDE PANEL TO PREVENT CLAMP FROM SCRATCHING THE PAINT.
5. PLACE THE 10MM RUBBER PAD UNDER THE SIDE PANEL, BETWEEN THE PICKUP BOX AND THE SMARTCAP, DIRECTLY UNDER THE POSITION YOU INTEND TO INSTALL THE C CLAMP. (SEE FIGURE 4)
6. PLACE 3 RUBBER PADS IN LINE WITH CLAMPS ON THE BIN LINING, 4TH PAD TO BE PLACED AS A SPACER TOWARDS THE REAR OF THE BIN (SEE FIGURE 4.1), PROCEED TO SUFFICIENTLY TORQUE THE CLAMPS TO 9 FT-LB, 108 IN-LB OR 12.2 NM.

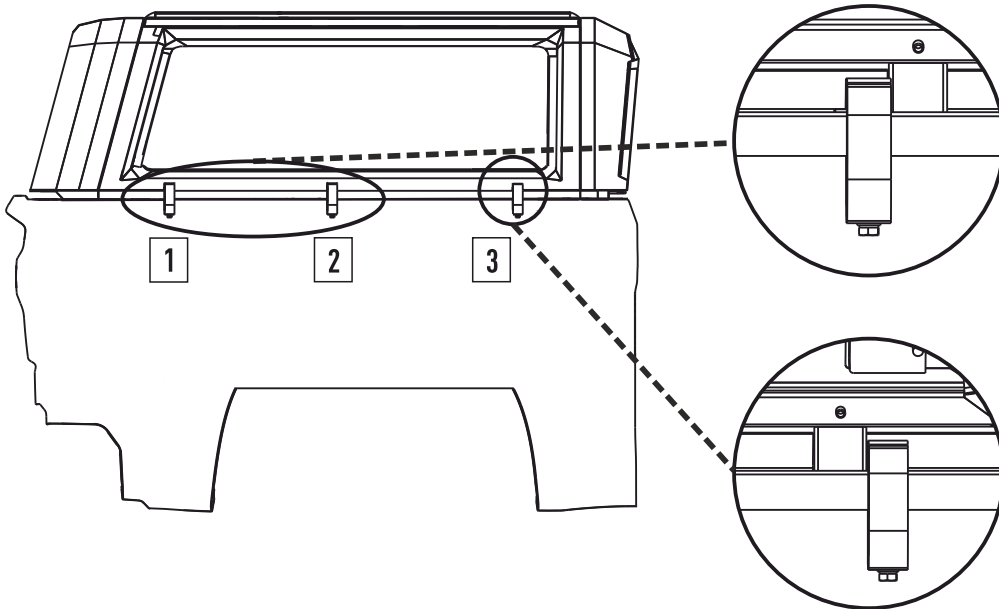

FIGURE 3

REPEAT THIS PROCEDURE ON THE OPPOSITE HAND SIDE OF THE VEHICLE.

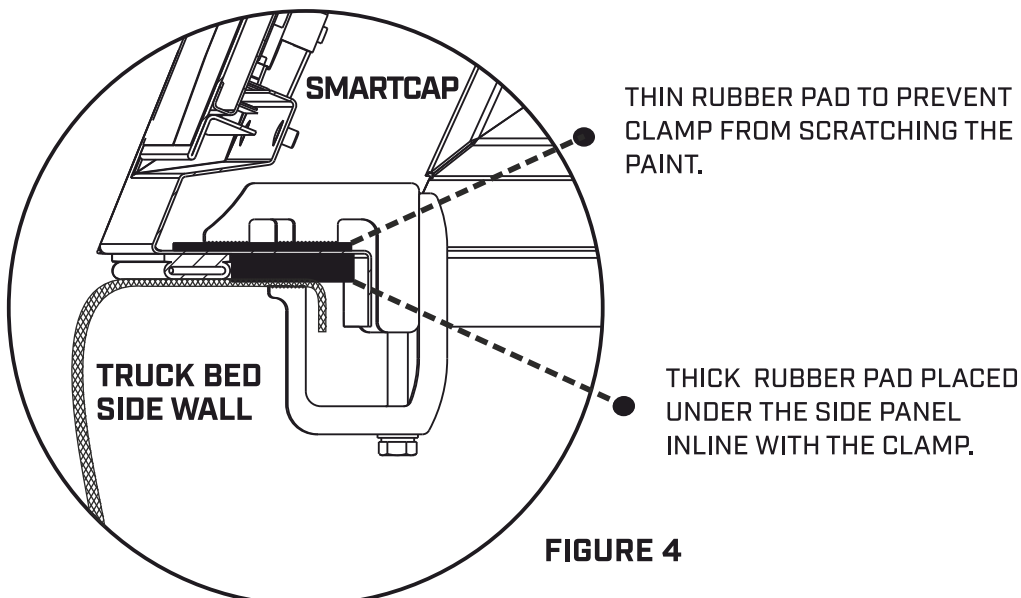

FIGURE 4

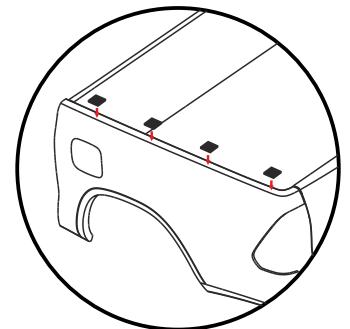

FIGURE 4.1

INSTALLATION OF THE SMARTCAP

JEEP GLADIATOR - WITH TRAIL RAIL

STEP ONE



1. A MINIMUM OF FOUR PEOPLE ARE RECOMMENDED TO PICK UP AND PLACE THE SMARTCAP ONTO THE TRUCK.
2. TO KEEP FROM DAMAGING YOUR D-RUBBER DURING THE INSTALLATION PROCESS, IT IS IMPORTANT YOU LIFT THE SMARTCAP IN PLACE AND DO NOT DRAG IT ACROSS THE TRUCK BED RAILS.
3. ONCE THE SMART CAP IS CENTERED, SLIDE THE BOTTOM HALF OF THE CLAMP INTO THE SLIDE RAILS OF THE TRUCK BED. (SEE FIGURE 3)
4. PLACE THE SUPPLIED THIN RUBBER PAD ON THE SIDE PANEL TO PREVENT CLAMP FROM SCRATCHING THE PAINT.
5. PLACE THE 10MM RUBBER PAD UNDER THE SIDE PANEL, BETWEEN THE PICKUP BOX AND THE SMARTCAP, DIRECTLY UNDER THE POSITION YOU INTEND TO INSTALL THE C CLAMP. (SEE FIGURE 5)
6. PLACE 3 RUBBER PADS INLINE WITH CLAMPS ON THE BIN LINING, 4TH PAD TO BE PLACED AS A SPACER TOWARDS THE REAR OF THE BIN (SEE FIGURE 2), PROCEED TO SUFFICIENTLY TORQUE THE CLAMPS TO 9 FT-LB, 108 IN-LB OR 12.2 NM.

FIGURE 2

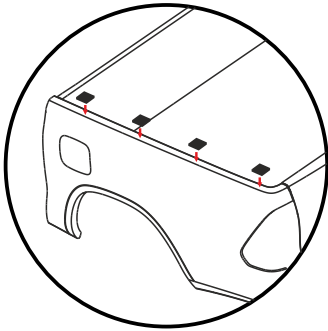
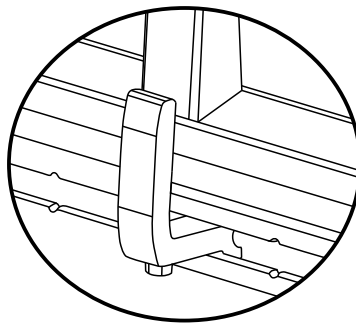

FIGURE 3



SLIDE BOTTOM HALF OF CLAMP INTO SLIDE RAIL OF TRUCK BED.

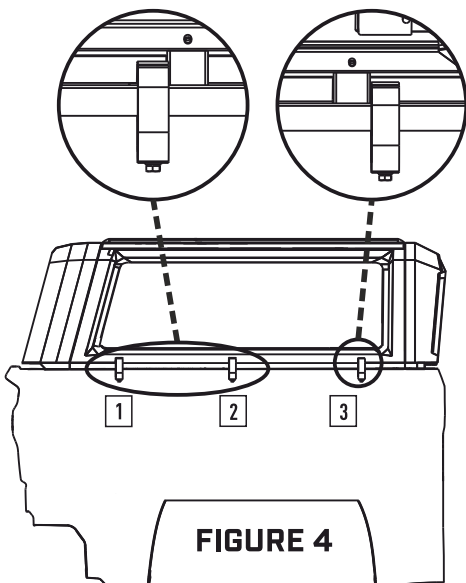
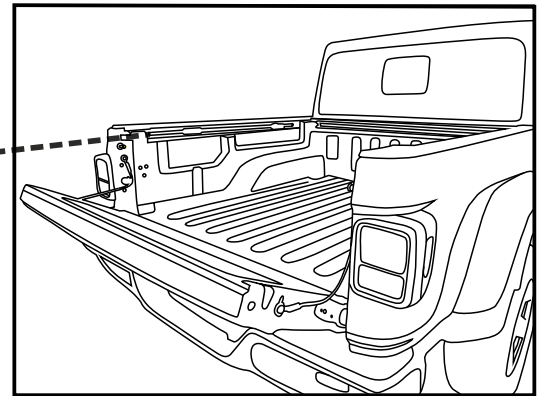
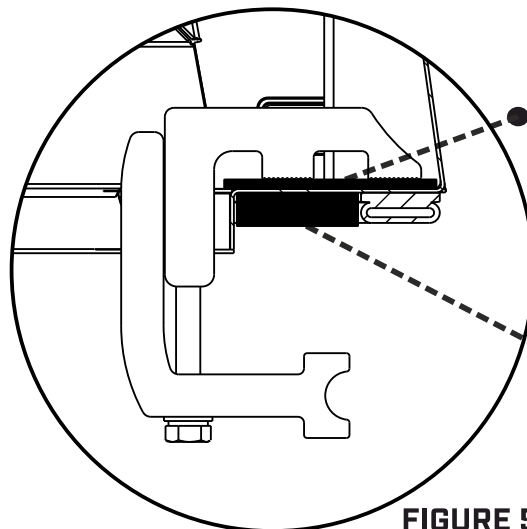

FIGURE 4



THIN RUBBER PAD TO PREVENT CLAMP FROM SCRATCHING THE PAINT.

THICK RUBBER PAD PLACED UNDER THE SIDE PANEL INLINE WITH THE CLAMP.

FIGURE 5

INSTALLATION OF THE SMARTCAP

FORD RANGER

STEP ONE



1. SOME TRUCK BEDS MAY HAVE HEIGHT DIFFERENCES BETWEEN THE SIDES AND FRONT OF THE TRUCK BED. IF THAT IS THE CASE WITH YOUR TRUCK BED, APPLY A FOAM STRIP TO THE LIP OF THE FRONT PANEL.
2. REMOVE THE ADHESIVE BACKING TAPE FROM THE FOAM STRIP. [SEE FIGURE 1]
3. APPLY FOAM STRIP ON THE FRONT LIP OF THE PICK UP BOX TO ACCOUNT FOR ANY HEIGHT DIFFERENCES BETWEEN THE PICKUP BOX SIDES AND THE FRONT PICKUP BOX PANEL. [SEE FIGURE 2]
4. CUT TO LENGTH. [SEE FIGURE 3]

FIGURE 1

- 1. FOAM STRIP
- 2. ADHESIVE
- 3. ADHESIVE BACKING

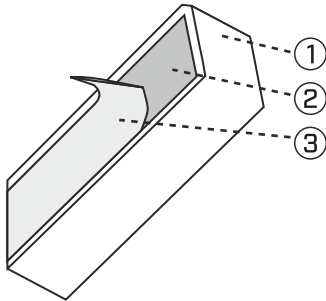

FIGURE 2

- FOAM STRIP FRONT PICKUP BOX PANEL

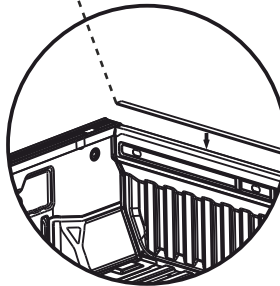
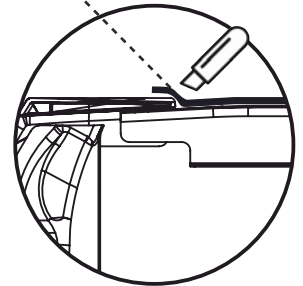

FIGURE 3

- FOAM STRIP TRIM EXCESS FOAM STRIP



STEP TWO



1. POSITION THE FRONT MOUNT BRACKET IN THE FRONT LEFT HAND CORNER OF THE LOAD BIN.
2. USE ONE M6/M8 SET SCREW, WITH M6/M8 SPRING WASHER AND M6/M8 FENDER WASHER TO LOOSELY SCREW THE BRACKET TO THE FRONT OF THE LOAD BIN.
3. USE FOUR M8 X 25 SET SCREWS WITH FOUR M8 SPRING WASHERS AND M8 X 25 FENDER WASHERS TO FASTEN THE BRACKET TO THE SIDE OF THE LOAD BIN
4. REPEAT THIS PROCESS IN THE FRONT MOUNT BRACKET RIGHT HAND SIDE IN THE FRONT RIGHT HAND CORNER OF THE LOAD BIN.

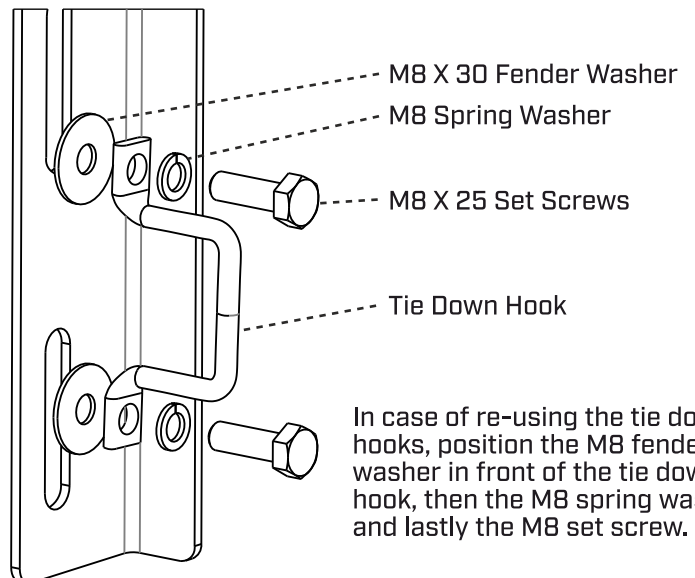
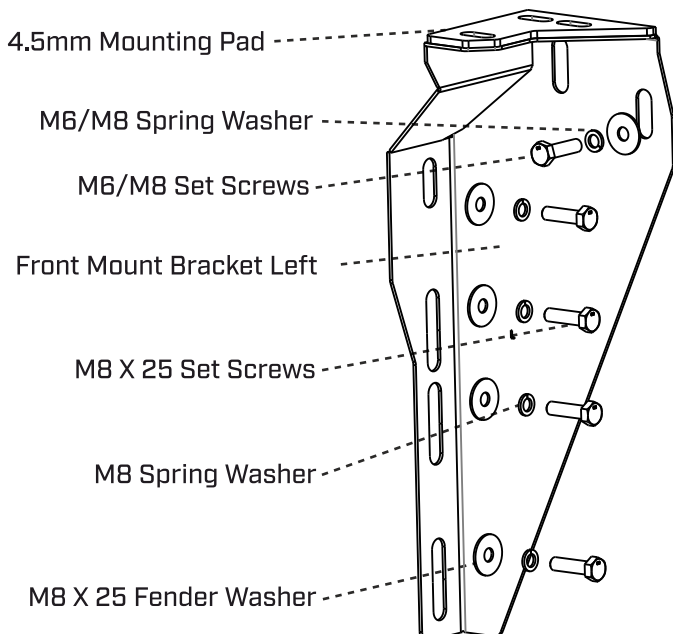

In case of re-using the tie down hooks, position the M8 fender washer in front of the tie down hook, then the M8 spring washer and lastly the M8 set screw.

INSTALLATION OF THE SMARTCAP

FORD RANGER

STEP THREE

1. POSITION THE REAR MOUNT BRACKET LEFT HAND IN THE REAR LEFT HAND CORNER OF THE LOAD BIN.
2. USE TWO M8 X 25 SET SCREWS WITH M8 SPRING WASHERS AND M8 X 25 FENDER WASHERS TO LOOSELY SCREW THE BRACKET TO THE REAR OF THE LOAD BIN.
3. REPEAT THIS PROCESS IN THE REAR MOUNT BRACKET RIGHT HAND SIDE IN THE REAR RIGHT HAND CORNER OF THE LOAD BIN.

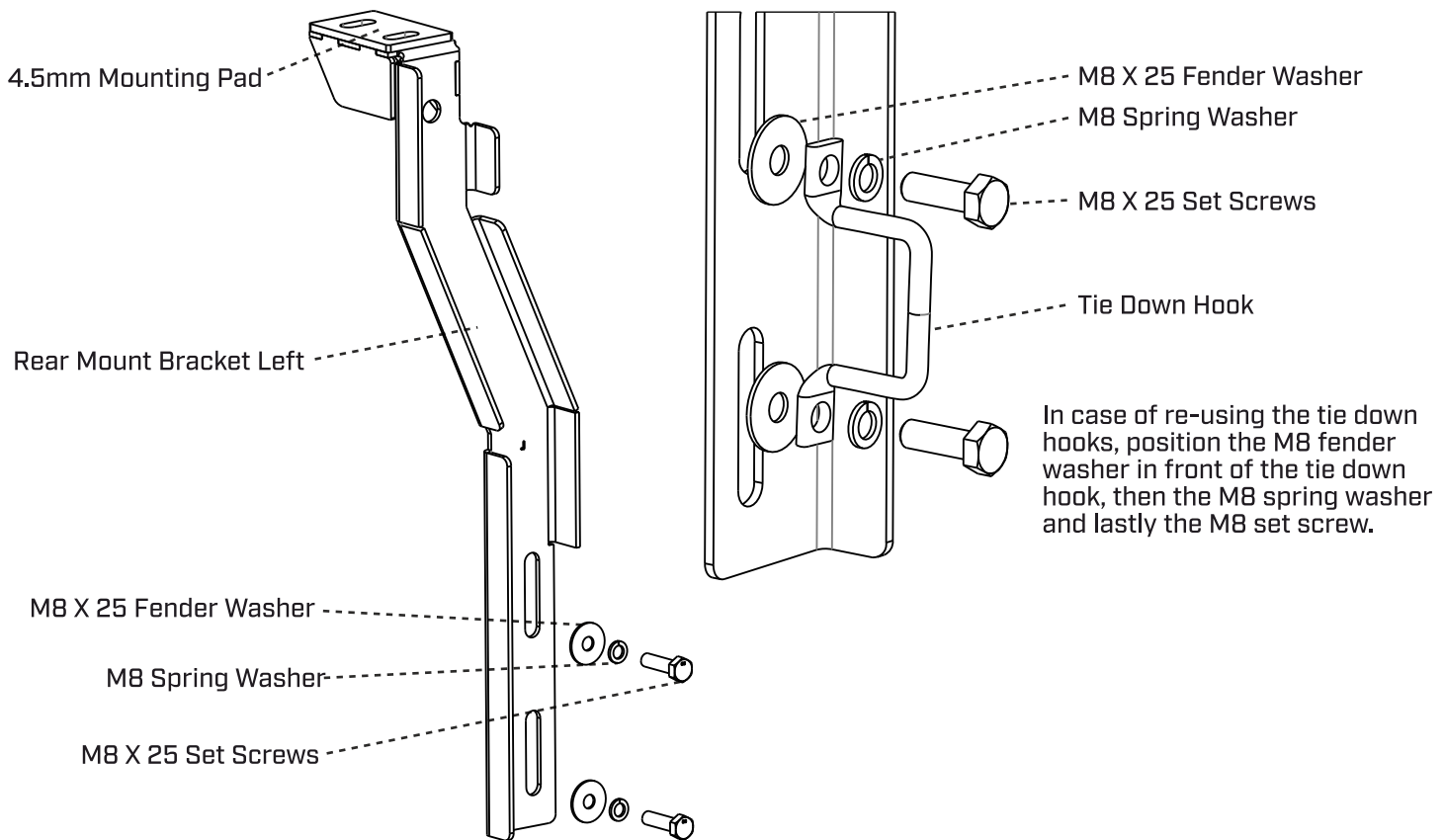

STEP FOUR

1. PLACE THE SMARTCAP ONTO THE LOAD BIN.
2. PLEASE LIFT WITH CAUTION TO PREVENT POSSIBLE INJURY. IT IS RECOMMENDED THAT A MINIMUM OF FOUR PEOPLE ARE USED TO LIFT THE SMARTCAP.
3. MAKE SURE THE CAP IS IN ITS CORRECT POSITION BY LINING UP THE SLOTS ON THE SMARTCAP WITH THE SLOTS ON THE MOUNTING BRACKETS.

INSTALLATION OF THE SMARTCAP

FORD RANGER

STEP FIVE



1. USE SIX M8 X 30 SET SCREWS WITH TWELVE M8 X 25 FENDER WASHERS AND SIX M8 NYLOC NUTS TO LOOSELY FASTEN THE SMARTCAP TO THE FRONT MOUNT BRACKETS.
2. USE FOUR M8 X 25 SET SCREWS WITH EIGHT M8 X 25 FENDER WASHERS AND FOUR M8 NYLOC NUTS TO LOOSELY FASTEN SMARTCAP TO THE REAR MOUNT BRACKETS.
3. ONCE ALL THE SET SCREWS ARE IN THEIR CORRECT POSITIONS, FASTEN TO 12NM OR 8.9 FT-LBS.

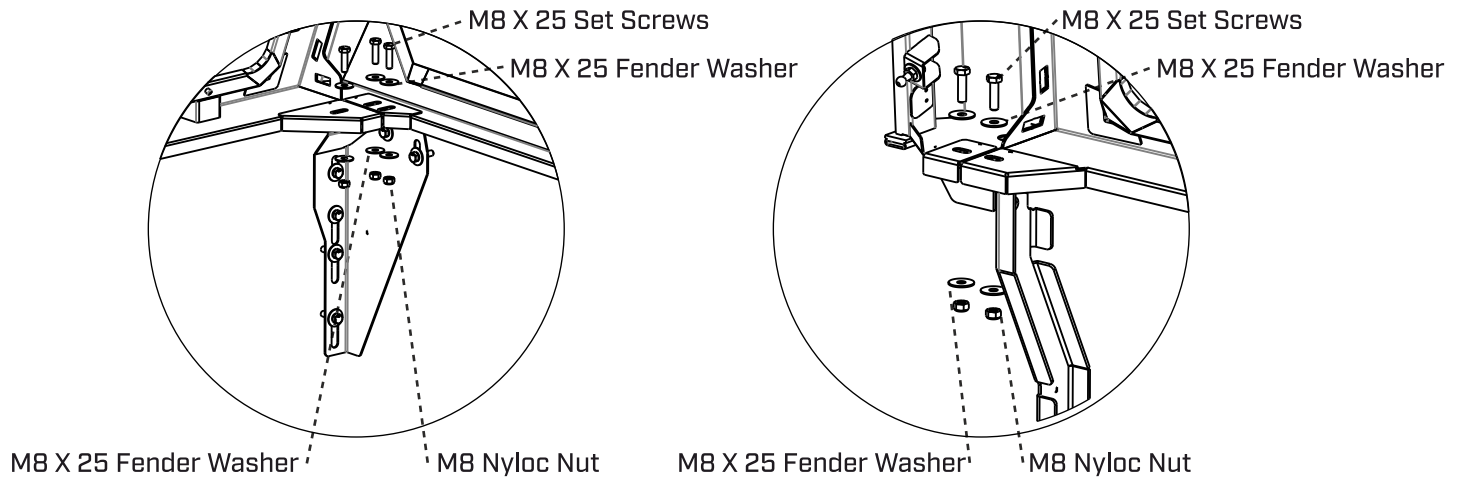

INSTALLATION OF THE SMARTCAP

TOYOTA TACOMA

STEP ONE



1. PICK UP THE RSI SMARTCAP, A MINIMUM OF FOUR PEOPLE ARE RECOMMENDED, PLACE ONTO THE PICKUPS LOADBIN AND ENSURE THE RSI SMARTCAP IS CENTERED.
2. ONCE THE RSI SMARTCAP IS CENTERED, SLIDE CLAMPS INTO THE BIN MOUNTING RAILS PLEASE NOTE THERE ARE 3 CLAMPS PER SIDE (SEE FIGURE 4)
3. REPEAT THIS PROCESS ON THE OPPOSITE SIDE OF THE PICKUP.
4. PLACE 3 RUBBER PADS INLINE WITH CLAMPS ON THE BIN LINING, 4TH PAD TO BE PLACED AS A SPACER TOWARDS THE REAR OF THE BIN (SEE FIGURE 4.1)

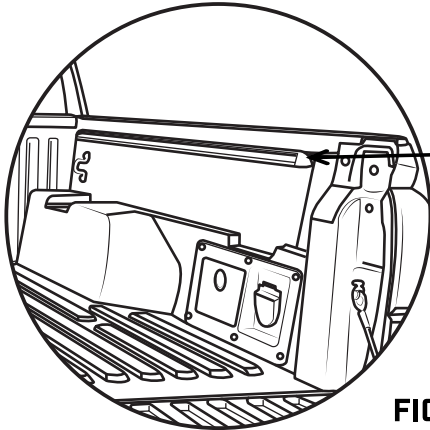

FIGURE 4

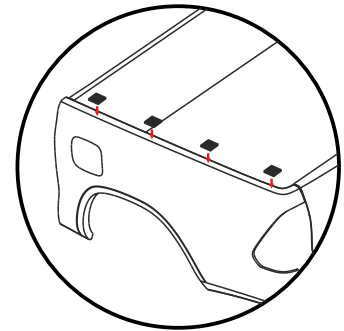
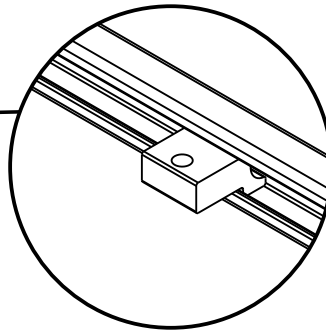

FIGURE 4.1

STEP TWO

1. SLIDE THE CLAMPS ALONG THE SIDE RAIL, ALIGN WITH MOUNTING HOLES. (SEE FIGURES 5)
2. WORK WITH CAUTION TO PREVENT DAMAGE.
3. REPEAT THIS PROCESS ON THE OPPOSITE SIDE OF THE PICKUP.

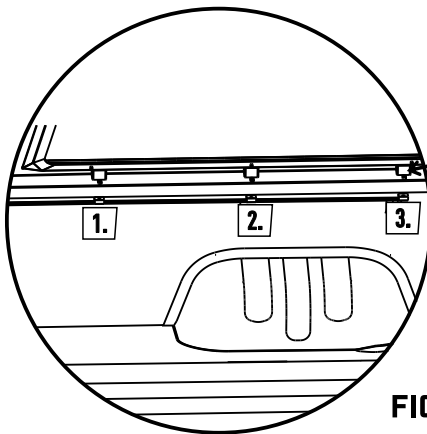
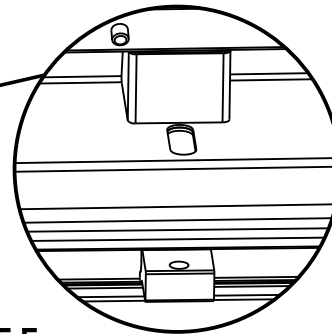

FIGURE 5



STEP THREE

1. THREAD THE FASTENING BOLTS THROUGH THE SLOTS IN THE RSI SMARTCAP.
2. TORQUE TO 9FT-LB, 108 IN-LB OR 12.2 NM.
3. PLEASE USE CAUTION WHEN TIGHTENING TO AVOID ANY DAMAGE.
4. SEE FIGURE 6 BELOW FOR MORE CLARITY.

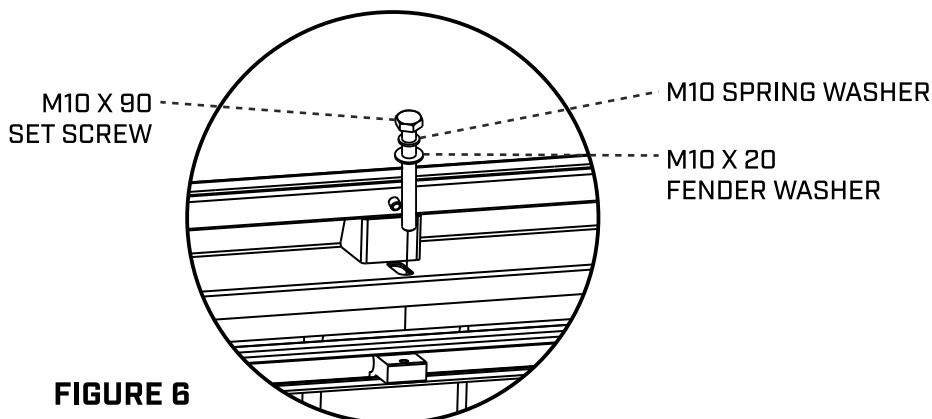

FIGURE 6

THIRD BRAKE LIGHT WIRING

GM SILVERADO - GM COLORADO - DODGE RAM - FORD F-SERIES - FORD RANGER
TOYOTA TUNDRA



WARNING

- VEHICLE SHOULD BE TURNED OFF WHEN INSTALLING THE T-HARNESS.
- ALL STEPS MUST BE FOLLOWED TO ENSURE THE CORRECT FUNCTION OF THE THIRD BRAKE LIGHT AND TRAILER PLUG.
- TO VERIFY PROPER INSTALLATION, TEST BY CONNECTING A TEST LIGHT OR PROPERLY WIRED TRAILER.



1X THIRD BRAKE LIGHT
WIRE HARNESS

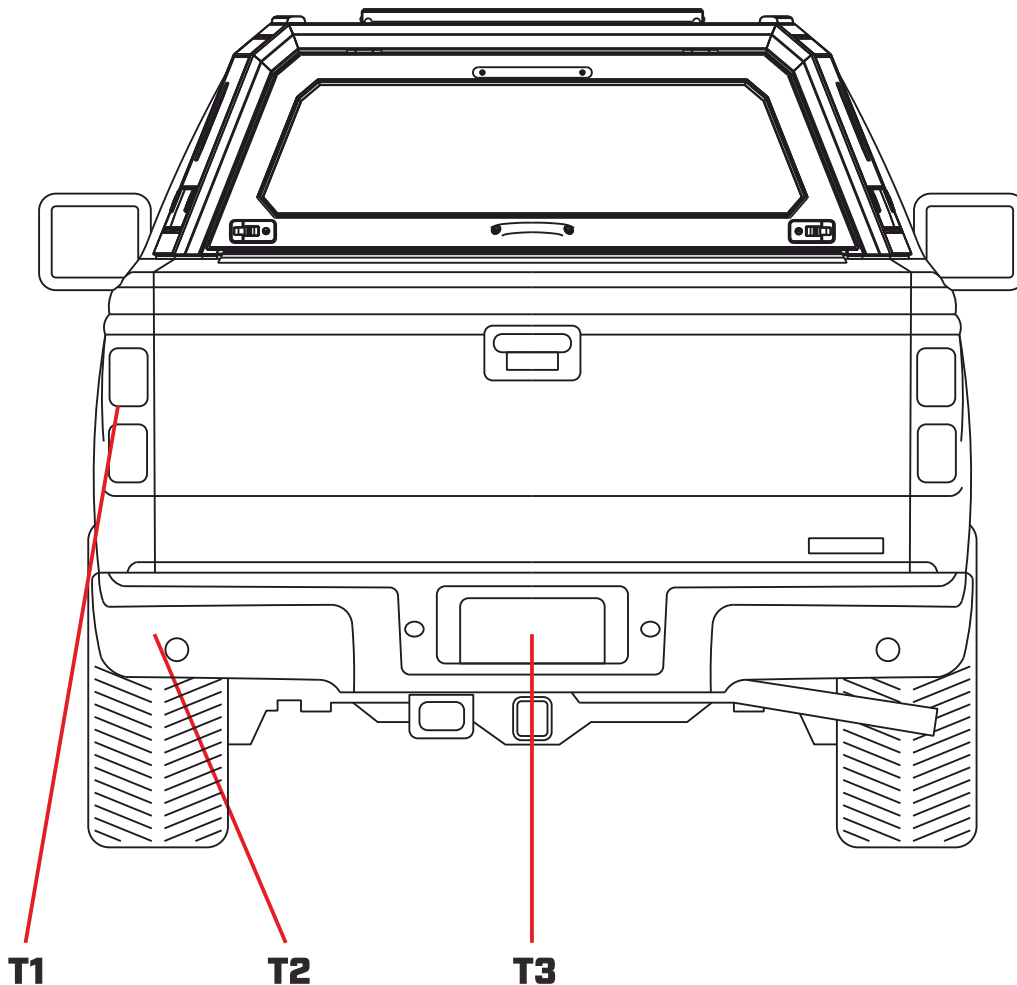

WIRING REFERENCE GUIDE



REMOVE TAILLIGHT HOUSING



LOCATE FACTORY 7-WAY

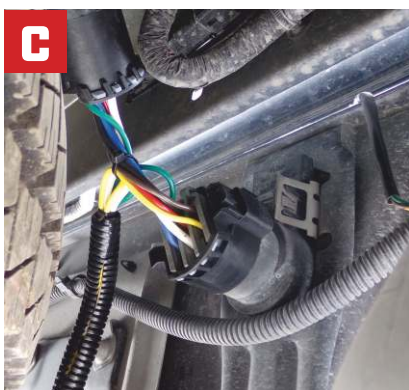

CONNECTED T HARNESS



ROUTING THE WIRE HARNESS



ROUTING THE WIRE HARNESS



ROUTE WIRE HARNESS THROUGH UP TO THE CONTROL BOX



ROUTE WIRE HARNESS BEHIND TAILLIGHT



SECURELY ZIP TIE HARNESS

FOR VEHICLES WITH A FACTORY 7 WAY

STEP ONE

- WITHOUT DISCONNECTING THE TAILLIGHT, REMOVE THE DRIVER' S SIDE TAILLIGHT ASSEMBLY, REVEALING THE CAVITY BEHIND THE TAILLIGHT. **REFER TO [T1] AND PICTURE (A)**

STEP TWO

- LOCATE THE FACTORY 7-WAY CONNECTOR ATTACHED TO EITHER THE BUMPER OR HITCH.
- REMOVE THE PLUG FROM THE BACK OF THE FACTORY 7-WAY CONNECTOR. **REFER TO [T3] AND PICTURE (B)**

STEP THREE

- INSERT THE SUPPLIED T-HARNESS BETWEEN THE FACTORY PLUG AND THE FACTORY 7-WAY CONNECTOR. BE SURE THAT BOTH ENDS OF THE T-HARNESS ARE FULLY INSERTED WITH THE LOCKING TABS IN PLACE. **REFER TO PICTURE (C)**

STEP FOUR

- ROUTE THE 2 PIN PLUG ON THE T-HARNESS ALONG THE BACK SIDE OF THE REAR BUMPER TOWARDS THE DRIVER'S SIDE TAILLIGHT. **REFER TO PICTURE (D)**

STEP FIVE

- LOCATE THE CABLE CHASE THAT THE TAILLIGHT WIRING IS RUNNING THROUGH AND ROUTE THE 2 PIN PLUG FROM THE T-HARNESS INTO THE TAILLIGHT CAVITY. **REFER TO PICTURE (E)**

STEP SIX

- PULL THE WIRE HARNESS THROUGH THE CABLE CHASE UP TO THE BLACK BOX ON THE WIRE HARNESS. **REFER TO PICTURE (F)**

STEP SEVEN

- FROM YOUR SMARTCAP, ROUTE THE THIRD BRAKE LIGHT 2-PIN PLUG THROUGH THE TRUCK'S REAR BED POST AND INTO THE TAILLIGHT CAVITY.

STEP EIGHT

- CONNECT THE 2-PIN PLUG FROM THE T-HARNESS TO THE SMARTCAP'S THIRD BRAKE LIGHT 2-PIN CONNECTOR. REINSTALL THE DRIVER'S SIDE TAILLIGHT ASSEMBLY. **REFER TO PICTURE (G)**

STEP NINE

- START YOUR TRUCK. PLEASE NOTE, ON SOME TRUCKS IT MAY TAKE 30 SECONDS FOR THE VEHICLE TO DETECT THE CONNECTION. TEST THE BRAKE LIGHTS AND TURN SIGNALS. CHECK TO MAKE SURE PROPER TURN SIGNAL FUNCTIONALITY WHEN THE BRAKE LIGHTS ARE ON.

STEP TEN

- ONCE YOU ARE SURE EVERYTHING IS FUNCTIONING CORRECTLY, SECURE THE CONTROL BOX AND THE WIRING HARNESS BEHIND THE REAR BUMPER USING ZIP TIES. BE SURE THAT THE WIRING HARNESS DOES NOT INTERFERE WITH ANY MOVING PARTS OF THE VEHICLE. **REFER TO PICTURE (H)**

After the installation of the wiring harness on some vehicles you might get an error for a disconnected trailer. If this error occurs and your vehicle is equipped with vehicle towing software, navigate in the software and manually enable power to the 7-way. This might appear as "enable auxiliary" or "enable trailer". If CHMSL does not work, shut engine off. Wait 10 seconds and restart engine. Wait an additional 10 seconds for the vehicle to detect CHMSL.

WARNING: ALWAYS TEST TRAILER LIGHT FUNCTIONS WHEN ATTACHING A TRAILER WHILE USING THIS SYSTEM.

FOR VEHICLES WITHOUT A FACTORY 7 WAY

STEP ONE

- WITHOUT DISCONNECTING THE TAILLIGHT, REMOVE THE DRIVER' S SIDE TAILLIGHT ASSEMBLY, REVEALING THE CAVITY BEHIND THE TAILLIGHT. **REFER TO (T1) AND PICTURE (A)**

STEP TWO

- LOCATE THE TOW VEHICLE'S TRAILER HARNESS PLUG. THIS HARNESS IS LOCATED UNDER THE VEHICLE, BEHIND THE BUMPER, ON THE DRIVER'S SIDE OF THE TRUCK. **REFER TO (T2)**

STEP THREE

- REMOVE THE PROTECTIVE CAP FROM THE PLUG AND SAVE. CHECK TO SEE THAT THE MATING SURFACE OF THE HOUSING IS FREE OF DIRT AND CLEAN IF NECESSARY.

STEP FOUR

- INSERT THE T-CONNECTOR INTO THE VEHICLE'S PLUG. BE SURE THAT THE T-CONNECTOR IS FULLY INSERTED WITH LOCKING TABS IN PLACE.
- PLACE PROTECTIVE CAP ON THE REMAINING PLUG END.

STEP FIVE

- ROUTE THE 2 PIN PLUG ON THE T-HARNESS ALONG THE BACK SIDE OF THE REAR BUMPER TOWARDS THE DRIVER'S SIDE TAILLIGHT. **REFER TO PICTURE (D)**

STEP SIX

- LOCATE THE CABLE CHASE THAT THE TAILLIGHT WIRING IS RUNNING THROUGH AND ROUTE THE 2 PIN PLUG FROM THE T-HARNESS INTO THE TAILLIGHT CAVITY. **REFER TO PICTURE (E)**

STEP SEVEN

- PULL THE WIRE HARNESS THROUGH THE CABLE CHASE UP TO THE BLACK BOX ON THE WIRE HARNESS. **REFER TO PICTURE (F)**

STEP EIGHT

- FROM YOUR SMARTCAP, ROUTE THE THIRD BRAKE LIGHT 2-PIN PLUG THROUGH THE TRUCK'S REAR BED POST AND INTO THE TAILLIGHT CAVITY.

STEP NINE

- CONNECT THE 2-PIN PLUG FROM THE T-HARNESS TO THE SMARTCAP'S THIRD BRAKE LIGHT 2-PIN CONNECTOR.
- REINSTALL THE DRIVER'S SIDE TAILLIGHT ASSEMBLY. **REFER TO PICTURE (G)**

STEP TEN

- START YOUR TRUCK. PLEASE NOTE, ON SOME TRUCKS IT MAY TAKE 30 SECONDS FOR THE VEHICLE TO DETECT THE CONNECTION. TEST THE BRAKE LIGHTS AND TURN SIGNALS. CHECK TO MAKE SURE PROPER TURN SIGNAL FUNCTIONALITY WHEN THE BRAKE LIGHTS ARE ON.

STEP ELEVEN

- ONCE YOU ARE SURE EVERYTHING IS FUNCTIONING CORRECTLY, SECURE THE CONTROL BOX AND THE WIRING HARNESS BEHIND THE REAR BUMPER USING ZIP TIES. BE SURE THAT THE WIRING HARNESS DOES NOT INTERFERE WITH ANY MOVING PARTS OF THE VEHICLE.

THIRD BRAKE LIGHT WIRING

TOYOTA TACOMA



WARNING

- VEHICLE SHOULD BE TURNED OFF WHEN INSTALLING THE T-HARNESS.
- ALL STEPS MUST BE FOLLOWED TO ENSURE THE CORRECT FUNCTION OF THE THIRD BRAKE LIGHT AND TRAILER PLUG.
- TO VERIFY PROPER INSTALLATION, TEST BY CONNECTING A TEST LIGHT OR PROPERLY WIRED TRAILER.



1X 3RD REAR BRAKE LIGHT
WIRE HARNESS

WIRING REFERENCE GUIDE

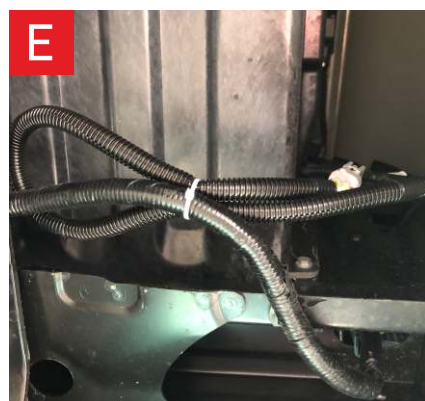

WIRING REFERENCE GUIDE

STEP ONE

- REMOVE THE LEFT HAND SIDE TAILLIGHT ASSEMBLY, REVEALING THE CAVITY BEHIND THE TAILLIGHT. REFER TO PICTURE (A)

STEP TWO

- LOCATE THIRD BRAKE LIGHT 2-PIN PLUG HANGING OFF THE SMARTCAP ON THE LEFT HAND SIDE NEAR THE TAILGATE AND CONNECT THE T-HARNESS TO IT. REFER TO PICTURE (B)

STEP THREE

- INSERT THE SUPPLIED T-HARNESS BETWEEN THE FACTORY PLUG AND THE FACTORY 7-WAY CONNECTOR. BE SURE THAT BOTH ENDS OF THE T-HARNESS ARE FULLY INSERTED WITH THE LOCKING TABS IN PLACE. REFER TO PICTURE (C1,2,3 & 4)

STEP FOUR

- DISCONNECT THE BRAKE LIGHT CABLE (MALE END) FROM THE TAILLIGHT ASSEMBLY AND CONNECT IT TO THE T-HARNESS (FEMALE CONNECTOR). THEN CONNECT THE T-HARNESS (MALE END) TO THE TAILLIGHT ASSEMBLY. REFER TO PICTURE (D)

STEP FIVE

- TEST THE BRAKE LIGHTS AND TURN SIGNALS. CHECK TO MAKE SURE PROPER TURN SIGNAL FUNCTIONALITY WHEN THE BRAKE LIGHTS ARE ON.

STEP SIX

- ONCE YOU ARE SURE EVERYTHING IS FUNCTIONING CORRECTLY, RE-INSTALL THE TAILLIGHT ASSEMBLY.

STEP SEVEN

- THERE WILL BE EXCESS CABLE UNDER YOUR VEHICLE THAT YOU SHOULD SECURE USING A ZIP-TIE. REFER TO PICTURE (E)

- 1) The rear door is not closing properly or closing is very difficult.
 - a) The mounting clamps have been overtightened. Ensure C-Clamp torque settings have been followed according to the Fitment Instructions and adjust where necessary.
 - b) The 10mm rubber spacers have not been inserted or positioned correctly during fitment to prevent overtightening.
 - c) The main D-Rubber (Weather Strip) is getting in the way because it has not been trimmed correctly as per the assembly instructions.
 - d) The rear door bubble rubber is getting in the way and has possibly come apart from the rear door lip.

- 2) The rear flange and door is not level (Higher/Lower on one end).
 - a) The mounting clamps have not been tightened evenly. Ensure C-Clamp torque settings have been followed according to the Fitment Instructions and adjust slightly where necessary.
 - b) The 10mm rubber pad spacers have not been inserted or positioned correctly during fitment.

- 3) There is a gap between the rear door rubber and the top of the tailgate.
 - a) The mounting clamps have not been tightened enough. Ensure C-Clamp torque settings have been followed according to the Fitment Instructions and adjust slightly where necessary.
 - b) The 10mm rubber spacers have not been inserted or positioned correctly during fitment.

- 4) The doors are not closing flush with the side panels or the rear flange.
 - a) The pressure lock levers need adjusting. This is recommended at least every months for Contractor Use and every 6 months for Leisure usage.

- 5) The rear door High-Level Brake light is not working.
 - a) Ensure that the plug connectors of the supplied wiring harness are connected properly and that the plug terminals have been configured correctly (Positive to positive etc..).

- 6) There is Dust and/or Water in the truck bed.

When a SmartCap EVO is properly assembled and installed, it will be water-tight. Unfortunately, we can't say the same about truck beds. In most cases, when water is leaking in through the truck bed it is coming in due to uneven surfaces between the bulkhead (front panel) and the sides of the bed. To combat this, we provide a foam strip for you to apply to fill the gap created by the height differences. Water can also penetrate a truck bed if there are gaps in the corners where the truck bed side and bulkhead rails come together. Should you encounter this issue, we recommend you use Butyl Tape to fill those gaps.

Here are a few things that can be checked to resolve this:

- a) Ensure that the D-Rubber (Weather Strip) is installed correctly between the bottom of the cap and the top of the bed rail.
- b) Ensure that Butyl Tape has been applied to the front bed rail where necessary.
- c) Ensure that the drain holes for the sliding windows are open.
- d) Check the ends of the D-Rubber (Weather Strip) at the rear corners of the Cap and ensure that they are cut and glued according to the assembly instructions.