



**2008 - 2018 Ford F250 / F350
4WD Super Duty
2.5" Leveling Kit
Installation Instructions**

REQUIRED TOOL LIST:

- Safety Glasses
- Metric / Standard Sockets & Wrenches
- Floor Jack
- Jack Stands
- Measuring Tape
- Torque Wrench



Component Box Breakdown:

Part #: F528MSP

Item #	Description	Qty	Item #	Description	Qty
F52MS-S	2.5" METAL SPACER	2	HB-TB5250	HDWR BAG: TRACK BAR BRK	1
TB1120-B	2" TRACK BAR BRACKET	1	I-F528MSP	INST SHEET: F528MSP	1
HB-F52MS	HDWR BAG: F52MS SPACERS	1			

Hardware Bag Breakdown:

Part # HB-F52MS

Item #	Description	Qty	Item #	Description	Qty
14X120MMB	14MM X 120MM BOLT	2	LT100	NUT N' BOLT 427 1 ML TUBE	1
916XTFW	9/16" EXTRA THICK WASHER	2			

Part # HB-TB5250

Item #	Description	Qty	Item #	Description	Qty
916X3FTB	9/16" X 3" FINE THREAD BOLT	3	916SAEW	9/16" SAE WASHER	6
916FTN	9/16" FINE THREAD LOCK NUT	3	D260PSS-S	TRACK BAR BRKT SPACERS	3

Installation:

1. With the vehicle on flat level ground, set the emergency brake, & block the rear tires / wheels.
2. Raise the front of the vehicle & support the vehicle securely using jack stands.
3. While supporting the front differential, remove the front tires / wheels using a 21mm socket.
4. Disconnect the OEM front sway bar end links from the OEM sway bar using a 18mm socket / wrench.
5. Disconnect the OEM ABS line & brake line brackets from the frame using a 13mm socket / wrench.
6. Disconnect the OEM 4WD actuator lines from the upper frame.
7. Disconnect the OEM drag link from the OEM pitman arm using a 24mm socket / wrench.
8. Disconnect the OEM track bar from the OEM track bar bracket using a 1 3/16" & 1 1/4" socket / wrench. (See Photo # 1)
9. Disconnect the OEM front shocks from each OEM lower shock mount using a 18mm & 21mm socket / wrench.



10. Lower the front differential & remove the OEM front coil springs. (See Photo # 2) **Note:** Retain the OEM upper rubber isolator pads, they will be used when the OEM front coil springs are re-installed.

11. Remove the OEM lower coil spring seats using a 18mm socket & install the new Skyjacker coil spring seat spacers, aligning the angle of the new coil spring seat spacers with the contour of each axle knuckle. (See Photo # 3)

12. Install the OEM coil spring seats on top of the new Skyjacker coil spring seat spacers, aligning the angle of the new coil spring seat spacers with the contour of each OEM coil spring seat. (See Photo # 3) **Note:** The OEM coil spring seat is labeled "FRT ↑" designating the orientation of the coil spring seat on the vehicle.

13. Install the supplied 9/16" washers onto the supplied 14mm bolts & apply the supplied thread locking compound to the threads of each new 14mm bolt. Install the new 14mm bolts thru the OEM coil spring seats & new Skyjacker coil spring seat spacers & tighten using a 22mm socket. (See Photo # 3)



Photo # 2

Photo # 3

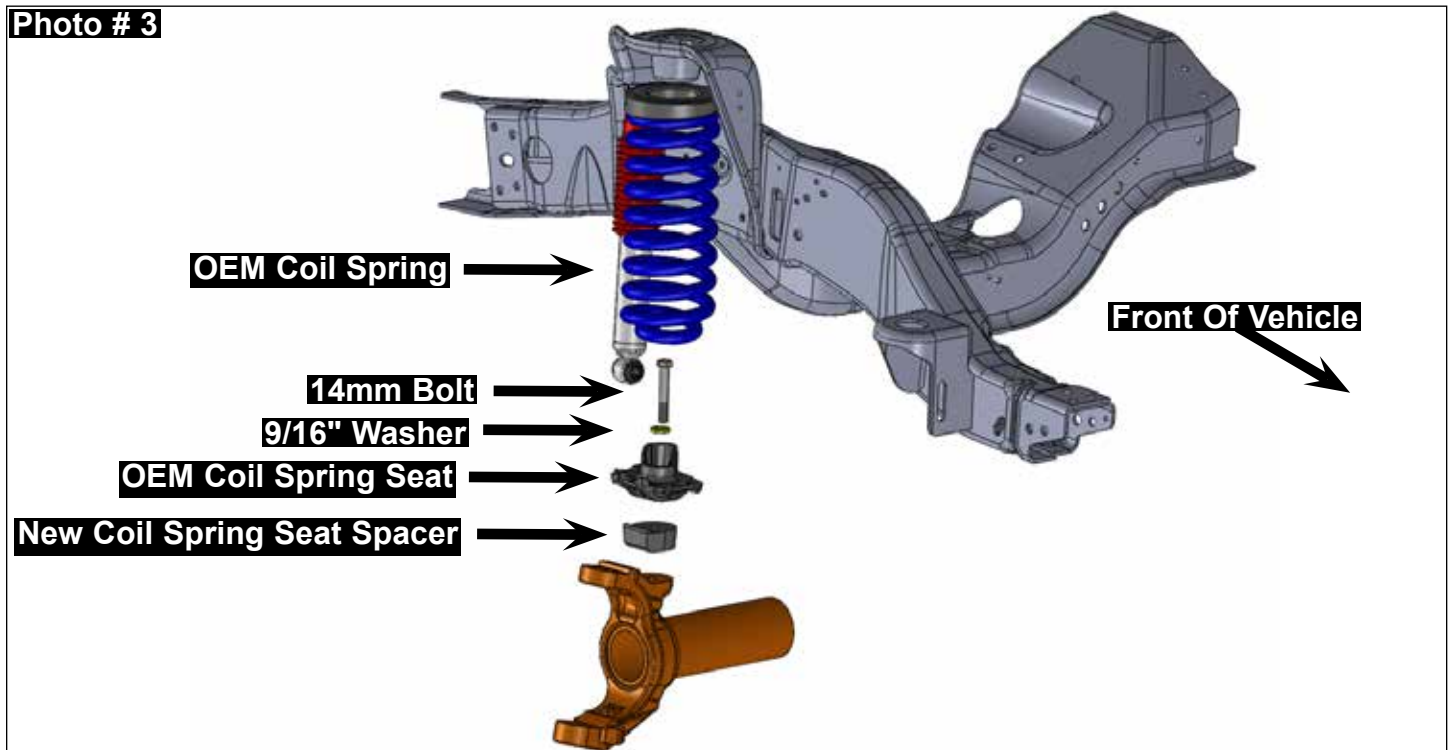

14. Remove the OEM track bar bracket from the frame & front cross member using a 18mm socket / wrench.

15. Install the new Skyjacker track bar bracket to the OEM location on the cross member using the supplied 9/16" x 3" fine thread bolts, 9/16" SAE washers, 9/16" nuts, a 13/16", & 7/8" socket / wrench. **Note:** Use the three supplied .938" long anti-crush spacers between the front of the new track bar bracket & the OEM cross member. Do not tighten at this time. (See Photo # 4)



Photo # 4

16. Complete the installation of the new Skyjacker track bar bracket to the frame using the OEM hardware, & a 18mm socket / wrench. (See Photo # 5) **Note:** Tighten the new track bar bracket hardware at this time using a 18mm, 13/16", & 7/8" socket / wrench.

17. Install the OEM front coil springs. (See Photo # 6) **Note:** Be sure to reuse the OEM rubber isolator pads on top of each OEM front coil spring.

18. Connect the OEM track bar to the new Skyjacker track bar bracket using the OEM hardware, a 1 3/16", & 1 1/4" socket / wrench .

19. Connect the OEM 4WD actuator lines at the upper frame.

20. Connect the OEM ABS line & brake line brackets to the frame using a 13mm socket / wrench.

21. Connect the OEM drag link to the OEM pitman arm using the OEM hardware & a 24mm socket / wrench.

22. Connect the OEM front sway bar end links to the OEM front sway bar using the OEM hardware & a 18mm socket / wrench.

23. Connect the OEM front shocks to each OEM lower shock mount using a 18mm & 21mm socket / wrench.

24. Install the front tires / wheels using a 21mm socket & lower the front of the vehicle to the ground.

Final Notes:

- After the installation is complete, double check that all nuts & bolts are tight. Refer to the following chart for the proper torque specifications. (Do not retighten the nuts & bolts where thread lock compound was used.)
- With the vehicle placed on the ground, cycle the steering lock to lock & inspect the steering, suspension, brake lines, front & rear drivelines, fuel lines, & wiring harnesses for proper operation, tightness, & adequate clearance.
- Have the headlights readjusted to the proper settings.
- Have a qualified alignment center align the vehicle to the OEM specifications.
- After the first 100 miles, check all hardware for the proper torque & periodically thereafter.



TORQUE SPECIFICATIONS

<u>INCH SYSTEM</u>			<u>METRIC SYSTEM</u>		
Bolt Size	Grade 5	Grade 8	Bolt Size	Class 8.8	Class 10.9
5/16	15 FT LB	20 FT LB	6MM	5 FT LB	9 FT LB
3/8	30 FT LB	35 FT LB	8MM	18 FT LB	23 FT LB
7/16	45 FT LB	60 FT LB	10MM	32 FT LB	45 FT LB
1/2	65 FT LB	90 FT LB	12MM	55 FT LB	75 FT LB
9/16	95 FT LB	130 FT LB	14MM	85 FT LB	120 FT LB
5/8	135 FT LB	175 FT LB	16MM	130 FT LB	165 FT LB
3/4	185 FT LB	280 FT LB	18MM	170 FT LB	240 FT LB

- The above specifications are not to be used when the bolt is being installed with a bushing.

Seat Belts Save Lives, Please Wear Your Seat Belt.