



# 04-14 GM Colorado / Canyon 2WD / 4WD 4" Suspension Lift Installation Instructions

## REQUIRED TOOL LIST:

- \* Safety Glasses
- \* Metric & Standard Wrenches & Sockets
- \* Drill & Assorted Drill Bits
- \* Floor Jack
- \* Grinder
- \* Jack Stands
- \* Measuring Tape
- \* Torque Wrench
- \* Transmission Jack
- \* Ball Joint Service Kit
- \* 3/8" Tap



Before beginning the installation, thoroughly & completely read these instructions & the enclosed driver's WARNING NOTICE. Affix the WARNING decal in the passenger compartment in clear view of all occupants. Please refer to the Parts List to insure that all parts & hardware are received prior to the disassembly of the vehicle.

Make sure you park the vehicle on a level concrete or asphalt surface. Many times a vehicle is not level (side-to-side) from the factory & is usually not noticed until a lift kit has been installed, which makes the difference more visible. Using a measuring tape, measure the front & rear (both sides) from the ground up to the center of the fender opening above the axle. Record this information below for future reference.

Driver Side Front: \_\_\_\_\_

Passenger Side Front: \_\_\_\_\_

Driver Side Rear: \_\_\_\_\_

Passenger Side Rear: \_\_\_\_\_

### Important Notes:

- The OEM wheels must be replaced. This lift requires wheels with 4.75" Back Spacing.
- Please be aware that some 4 cylinder models with need to modify the sway bar relocation bracket. (Re-drill the end link mounting hole.)
- This lift is determined from the amount of lift to the front of the vehicle, while only lifting the rear to a position level with the front.
- If larger tires (10% more than the OEM diameter) are installed, speedometer recalibration will be necessary. Contact your local GM dealer or an authorized dealer for details.

- After installation, a qualified alignment facility is required to align the vehicle to OEM specifications.

## Kit Box Breakdown:

### **CC409 (4WD) / CC429 (2WD):**

<u>ITEM #</u>	<u>DESCRIPTION</u>	<u>QTY</u>
CC49L	STEERING KNUCKLE, LEFT	1
CC49R	STEERING KNUCKLE,RIGHT	1
CC42FCM-S	COLORADO,FRONT CROSS-MEMBER	1
CC42RCM-S	4"COLORADO,REAR CROSS-MEMBER	1
CC40DDS-S (4WD)	4"COLORADO,DRIVER DIFF BRKT	1
CC40DPS-S (4WD)	4"COLORADO,PASSENGER DIFF BRKT	1
CC40DVS-S (4WD)	4"COLORADO,DRIVESHAFT SPACER	1
CC40TBD-L	4"COLO,TORSION BRKT, DRIVER	1
CC40TBD-R	4"COLO,TORSION BRKT,PASSENGER	1
CC40RCMB-S	4"COLO,REAR CROSS-MEMBER BUSHING	2
BSE40-S	BUMP STOP, 4" COLORADO	2
FBL48	FRONT BRAKE LINES	1
916X314X712U	9/16" X 3 1/4" X 7 1/2" U-BOLT	4
HB-CC40FCM	HDWR BAG:CC40 FRONT CROSS-MEMBER	1
HB-CC40RCM	HDWR BAG:CC40 REAR CROSS-MEMBER	1
HB-CC40DB (4WD)	HDWR BAG: CC40 DIFF BRACKETS	1
HB-CC40TBB	HDWR BAG:CC40 TORSION BRACKETS	1
HB-CC40SBLR	HDWR BAG:CC40 SWAY BAR LINKS	1
HB-CC40BSSD (4WD)	HDWR BAG:CC40 BUMP STOP/KNUCKLES	1
HB-CC40RBLU	HDWR BAG:BRAKE LINE/U-BOLTS	1
HB-CC42BSS (2WD)	HDWR BAG:CC42 BUMP STOP/KNUCKLES	1
HB-CC421 (2WD)	HDWR BAG:TRANS SPACER / DEGREE SHIMS	1
I-CC40	INSTRUCTION SHEET: CC409 / CC429	1

### Hardware Bag Breakdown:

<b>HB-CC40FCM</b>		
<u>ITEM #</u>	<u>DESCRIPTION</u>	<u>QTY</u>
58X512FTB	5/8 X 5 1/2 FINE THREAD BOLT	2
CFXS300-S	FRT CROSS-MEMBER SLEEVE,1"OD,3"LG	2
CC40-WASH	CROSS-MEMBER WASHER	4
58FTN	5/8-18 NYLON INSERT LOCKNUT	2
58SAEW	5/8 SAE WASHERS	4

<b>HB-CC40RCM</b>	<b>Rear Cross Member</b>	
<b><u>ITEM #</u></b>	<b><u>DESCRIPTION</u></b>	<b><u>QTY</u></b>
58X4FTB	5/8 X 4 FINE THD BOLT/GR 8	2
CRXS3375-S	COLO REAR XMEM SLEVE,3.375"	2
SP3684	REAR XMEMBER BUSHG,COLORADO	4
58FTN	5/8-18 NYLON INSERT LOCKNUT	2
58SAEW	5/8 SAE WASHERS	4
ZF316	ZERK FITTING ALEMITE, 3/16"	2

<b>HB-CC40DB (4WD)</b>	<b>Differential Brackets</b>	
<b><u>ITEM #</u></b>	<b><u>DESCRIPTION</u></b>	<b><u>QTY</u></b>
14X50MMB	14MM X 50 METRIC BOLT/ 10.9	4
14X80MMB	14MM X 80 METRIC BOLT/ 10.9	4
14MMN	14MM NYLON INSERT LOCK NUT	4
916SAEW	9/16 SAE WASHERS	12

<b>HB-CC40TBB</b>	<b>Torsion Bar Brackets</b>	
<b><u>ITEM #</u></b>	<b><u>DESCRIPTION</u></b>	<b><u>QTY</u></b>
12X30MMB	12MM X 30 METRIC BOLT/ 10.9	2
12X40MMB	12 X 40 METRIC BOLT/10.9	4
TS250	STEEL SLEEVE .250" LONG	6
12MMN	12 MM NUT (METRIC)	6
12SAEW	1/2 SAE WASHER	12

<b>HB-CC40SBLR</b>	<b>Sway Bar Links</b>	
<b><u>ITEM #</u></b>	<b><u>DESCRIPTION</u></b>	<b><u>QTY</u></b>
CC40SBB-L	4"COLO,SWAY BAR BRKT,DRIVER	1
CC40SBB-R	4"COLO,SWAY BAR BRKT,PASSENER	1
38X1FTB	3/8 X 1 FINE THREAD BOLT	2
38SAEW	3/8 SAE WASHER	4
38FTN	3/8-24 FINE N/I LOCK NUT	2

<b>HB-CC40BSSD (4WD)</b>	<b>Bump Stops / Steering Knuckles</b>	
<b><u>ITEM #</u></b>	<b><u>DESCRIPTION</u></b>	<b><u>QTY</u></b>
38X4BHB	3/8 X 4 BUTTON HEAD BOLT	2
10X50MMB	10 X 50 METRIC BOLT/10.9	4
5MMX12SHB	5MM X 12MM.80 KNUCKLE BOLTS	4
38HDCC-S	3/8 HEAVY DUTY CABLE CLAMP	4
LT100	NUTS N' BOLTS 427 1 ML TUBE	1

<b>HB-CC40RBLU</b>	<b>Rear Brakeline / U-Bolts</b>	
<b><u>ITEM #</u></b>	<b><u>DESCRIPTION</u></b>	<b><u>QTY</u></b>
8X60MMB	8MM X 60MM BOLT / 10.9	1
TS1125	STEEL SLEEVE 1.125" LONG	1
916FTN	9/16-18 NYLON INSERT LOCKNU	8

<b>HB-CC42BSS (2WD)</b>	<b>Bump Stops / Steering Knuckles</b>	
<b><u>ITEM #</u></b>	<b><u>DESCRIPTION</u></b>	<b><u>QTY</u></b>
38X4BHB	3/8 X 4 BUTTON HEAD BOLT	2
5MMX12SHB	5MM X 12MM.80 KNUCKLE BOLTS	4
38HDCC-S	3/8 HEAVY DUTY CABLE CLAMP	4
<b>HB-CC421 (2WD)</b>	<b>Trans Spacers / Degree Shims</b>	
<b><u>ITEM #</u></b>	<b><u>DESCRIPTION</u></b>	<b><u>QTY</u></b>
CC421-TS	1/2" TRANSMISSION SPACER	2
10STVMMN	10MM STOVER NUT	1
WS325-516	WS325 SHIMS, DRILLED 5/16"	2

**Front Installation:**

1. Park the vehicle on a level asphalt or concrete surface, set the emergency brake, & block the rear tires / wheels. Raise the front of vehicle & support the frame rails using jack stands.
2. Remove the OEM torsion bar adjusting bolt using a 27mm socket. **Note:** Be sure to measure the installed length of the OEM adjuster bolt before removal. After the lift installation, the OEM adjuster bolt will be reinstalled to this length. (See Photo # 1)
3. Remove the OEM torsion bar from the vehicle. **Note:** Be sure to mark as left & right side.
4. Remove the front tires / wheels using a 19mm socket. Disconnect the OEM upper brake line & ABS retaining clips. (See Photo # 2)
5. Remove the OEM outer tie rod end using a 21mm socket. (See Photo # 3) Remove the OEM front shocks using a 15mm & 18mm socket.
6. Remove the OEM brake caliper using a 21mm socket. Wire the brake caliper out of the way. The OEM brake line will be removed & replaced later in these instructions.
7. Remove the OEM sway bar end links using a 15mm socket. (See Photo # 4) **Note:** 2WD models proceed to Step # 9.
8. **4WD Models:** Remove the OEM cv-axle retaining nut using a 1 7/16" socket.

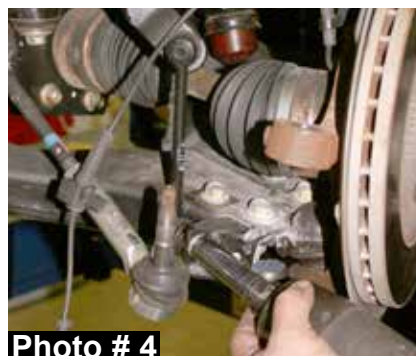
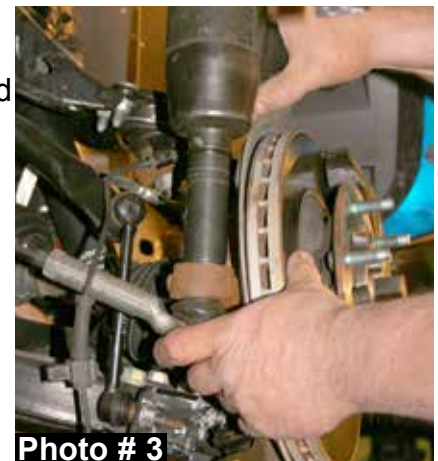



9. Disconnect the OEM upper & lower ball joints from the OEM steering knuckle using a 1 1/16" & 21mm socket. Remove the OEM steering knuckle. (See Photo # 5)
10. Remove the OEM lower a-arm retaining bolts using a 24mm & 18mm socket. (See Photo # 6) Remove the OEM front drive shaft using a 11mm wrench. **Note:** 2WD models proceed to Step # 12.
11. **4WD Models:** Support the front differential using a transmission jack. Disconnect the driver & passenger side of the differential mounts using a 18mm socket. (See Photo # 7) Lower the front differential out of the way.
12. To allow for the installation of the new Skyjacker kit, the rearward OEM a-arm bushing in the frame must be removed. A new Skyjacker aluminum bushing will be installed. Remove the rearward OEM a-arm frame bushings using a ball joint service kit. (See Photo # 8)
13. Install the new Skyjacker aluminum bushing into the frame. The new bushing will install from the front to rear. **Note:** Be sure the new bushing is seated flush when installed. (See Photo # 9) **Note:** 2WD models proceed to Step # 15.
14. **4WD Models:** Install the new Skyjacker driver & passenger differential brackets using the supplied 14mm x 50mm bolt, washers, & a 22mm socket. The new bolts will thread from the inside of the new bracket into the frame. (See Photo # 10) Attach the front differential to the new differential brackets using the supplied 14mm x 80mm bolts, washers, nuts, & a 22mm socket.
15. Install the new Skyjacker front cross member using the supplied 5/8" x 5 1/2" bolts, washers, nuts, & a 15/16" socket. **Note:** Be sure to install the new Skyjacker tapered washers between the new cross member & the OEM mount. See Arrows in Photo # 11. Be sure to use the new Skyjacker crush sleeve inside the OEM mount.
16. Locate the new Skyjacker rear cross member. Install the new Skyjacker 3/16" grease fittings into each end of the new cross member by tapping in using a 1/4" socket. Grease & install the new Skyjacker bushings & sleeves.



Photo # 5



Photo # 6



Photo # 7



Photo # 8



Photo # 9



Photo # 10

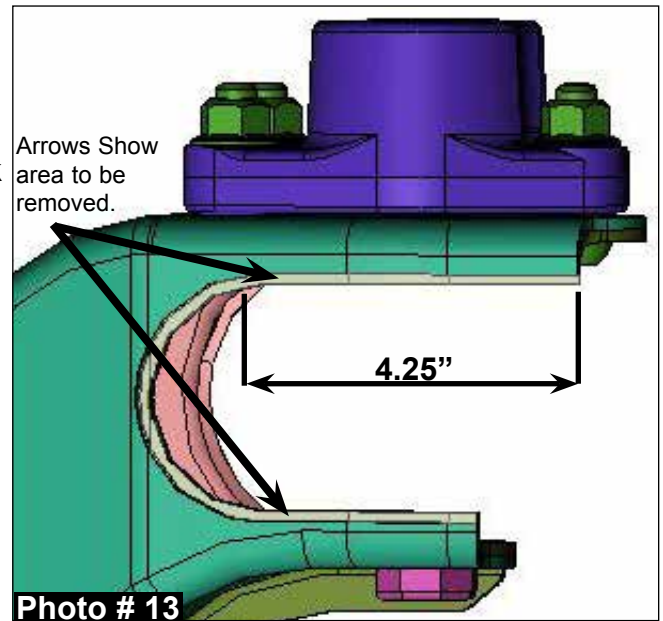

Photo # 11

17. Install the new Skyjacker rear cross member using the supplied 5/8" x 4" bolts, washers, nuts, & a 15/16" socket. (See Photo # 12)



18. The inside of the OEM lower a-arms must be ground to allow for clearance of the new Skyjacker cross member. Photo # 13 shows the inside of the a-arm. There are two layers of metal, the lower layer must be ground flush with the upper layer. (See Arrows in Photo # 13). Measure back 4 1/4" & mark the lower layer with a paint pen.



19. With the area marked, grind down the lower layer flush with the upper layer using a grinder or similar tool. (See Photo # 14) After grinding, check to make sure the a-arm will fit the new Skyjacker cross member.

20. Remove the OEM torsion bar bracket from the rear of the OEM lower a-arm using a 18mm socket & T55 torx socket. (See Photo # 15)

21. Attach the new Skyjacker torsion bar relocation brackets using the supplied 12mm x 40mm bolts in the outer two holes & a 19mm socket. (See Arrow in Photo # 16) **Note:** Be sure to use one 1/4" thick spacer at each bolt, between the new bracket & the a-arm. In the inward hole, install the supplied 12mm x 30mm bolt with the 1/4" spacer. Install this bolt from the outside in. Do not install the nut at this time. The bolt is only being installed to line up the bracket & 1/4" spacer.



22. Attach the OEM torsion bar mount to the new Skyjacker torsion bar relocation bracket using the OEM hardware, a 18mm socket & a T55 torx socket. Before a-arm installation, remove the inner most 12mm x 30mm bolt. (See Arrow in Photo # 17)

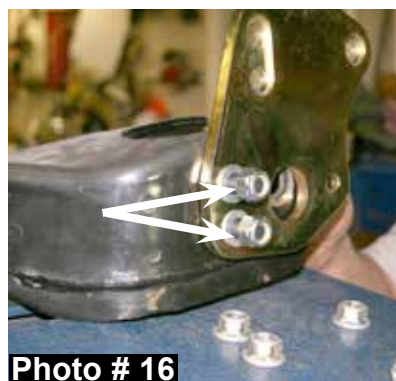



23. Attach the OEM lower a-arm to the new Skyjacker front & rear cross member using the OEM hardware, a 18mm socket, & a 24mm socket. (See Photo # 18)



24. Install the supplied inner 12x30mm bolt on the new Skyjacker torsion bar bracket using a 19mm socket. (See Photo # 19)

25. Hold the new Skyjacker bump stop extension centered against the bottom of the OEM upper bump stop (tapered end up). Raise the OEM a-arm up to the bottom of the new bump stop extension. (See Photo # 20) Lower the OEM a-arm down being sure to hold the new bump stop extension in place against the OEM a-arm.

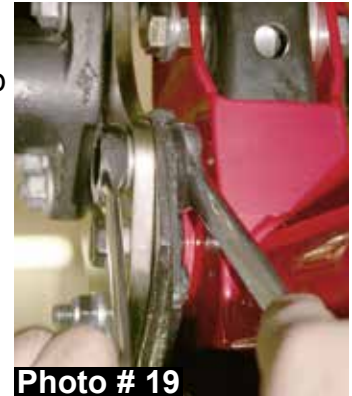

26. While holding the new Skyjacker bump stop extension securely to the OEM a-arm. Use a punch to mark the center location for the bolt. (See Photo # 22) With the hole marked, remove the new bump stop extension & drill this location using a 5/16" drill bit.

27. Once drilled, tap this hole using a 3/8"-16 thread pitch tap.

28. Once tapped, install the new Skyjacker bump stop extension using the supplied 3/8 x 4" button head bolts & a 7/32" hex key. Torque to 10 ft. lbs. (See Photo # 23)



29. Remove the OEM hub bearing assembly from the OEM steering knuckle using a 15mm socket. (See Photo # 24) Remove the OEM ABS line from the OEM steering knuckle using a 7mm socket.

30. Attach the OEM hub bearing assembly to the new Skyjacker steering knuckle using the OEM hardware & a 15mm socket. **Note:** Use the supplied thread locking compound on the threads of these bolts. (See Photo # 25)



31. Attach the OEM ABS line to the new Skyjacker steering knuckle using the supplied plastic clips, 5mm x 12mm bolt, & a 4mm hex key (See Photo # 26)



32. Attach the new Skyjacker steering knuckle assembly to the OEM upper & lower ball joints using the OEM hardware, a 1 1/16" socket, & a 21mm socket. Reattach the OEM ABS line at the upper a-arm. Remove the OEM brake line from the frame & OEM brake caliper.

33. Install the OEM brake caliper using the OEM hardware & a 21mm socket. Install the new Skyjacker Stainless Steel Braided brake line. (See Photo # 27)



34. **4WD Models:** Install the OEM cv-axle retaining nut using a 1 7/16" socket.

35. Install the new Skyjacker front sway bar end link brackets. (See Photo # 28) Remove the inner most forward ball joint retaining bolt from the OEM lower a-arm. Line up the new sway bar end link bracket mounting hole & reinstall the OEM ball joint bolt. Attach the new sway bar end link bracket to the OEM end link location using the supplied 3/8" x 1" fine thread bolt, washers, nuts, & a 9/16" socket. (See Arrow in Photo # 28) Attach the OEM end links to the OEM sway bar & new sway bar end link bracket using the OEM hardware & a 15mm socket. Reattach the outer tie rod end using a 21mm socket & install the new front shocks using the supplied hardware, OEM hardware, a 15mm socket, & a 18mm socket. **Note:** 2WD models proceed to Step # 37.



36. **4WD Models:** Install the OEM front drive shaft using the new Skyjacker drive shaft spacer between the OEM drive shaft & OEM transfer case using the supplied 10mm x 50mm bolts & a 17mm socket. (See Arrow in Photo # 29)



37. Install the OEM torsion bars & set the adjuster bolt back to the OEM length using a 27mm socket. (See Photo # 30)

38. Install the front tires / wheels using a 19mm socket & lower the vehicle to the ground.



### **Rear Installation:**

39. Block the front tires / wheels. Raise the rear of the vehicle & properly support the frame rails using jack stands. Remove the rear tires / wheels using a 19mm socket.



40. Remove the OEM rear shock using a 13mm & a 21mm socket.  
(See Photo # 31)



Photo # 31

41. Disconnect the OEM brake line retaining bolt from the differential.  
**Note:** Do not remove the lines from the fitting. (See Photo # 32)



Photo # 32

42. Remove the OEM rear u-bolts using a 21mm socket.

**Note:** 2WD Models must install the new Skyjacker degree shims with the new add-a-leafs or new leaf springs.

43. **Rear Add A Leaf:** To install, use two large c-clamps to secure the OEM rear leaf spring leaves together. With the c-clamps tightened, remove the center tie bolt. Install the new Skyjacker degree shim so the thick end will be towards the front of the vehicle when installed. Insert the new Skyjacker tie bolt & tighten.

44. Remove the emergency brake cable retaining bolt from the rear leaf spring using a 10mm socket. (Photo # 33)



Photo # 33

45. **Rear Leaf Spring:** Remove the OEM rear leaf springs using a 21mm socket. Install the new Skyjacker rear leaf springs using the OEM hardware & a 21mm socket. (See Photo # 34)

46. Install the new Skyjacker rear u-bolts using the supplied 9/16" nuts & a 13/16" socket.

47. Reattach the brake cable to the new Skyjacker rear leaf spring using the OEM hardware & a 10mm socket.



Photo # 34

48. Install the new Skyjacker rear shocks using the supplied hardware, OEM hardware, a 13mm & a 21mm socket. (See Photo # 35)

49. Install the new Skyjacker brake line spacer block. Secure the OEM T-block using the supplied 8mm x 60mm bolt & a 13mm socket. (See Photo # 36)



Photo # 35

50. Install the front tires / wheels using a 19mm socket & lower the vehicle to the ground.



Photo # 36

**Note:** 2WD Models must install the new Skyjacker transmission spacers. Using a transmission jack, support the bottom of the transmission. Remove the OEM transmission support bolts. Install the new transmission spacers as shown in the photo below. Use the supplied 10mm stover nut & a 17mm socket to secure the O2 sensor bracket as shown.

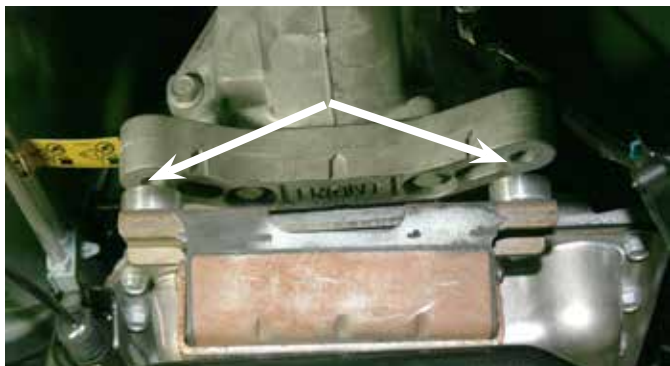

**Final Notes:**

- After the installation is complete, double check that all nuts & bolts are tight. Refer to the following chart below for the proper torque specifications. (Do not retighten the nuts & bolts where thread lock compound was used.)
- With the vehicle placed on the ground, cycle the steering lock to lock & inspect the steering, suspension, brake lines, front & rear drivelines, fuel lines, & wiring harnesses for proper operation, tightness, & adequate clearance.
- Have the headlights readjusted to the proper settings.
- Have a qualified alignment center align the vehicle to the OEM specifications.
- After the first 100 miles, check all hardware for the proper torque & periodically thereafter.

<b><u>TORQUE SPECIFICATIONS</u></b>					
<b><u>INCH SYSTEM</u></b>			<b><u>METRIC SYSTEM</u></b>		
<b>Bolt Size</b>	<b>Grade 5</b>	<b>Grade 8</b>	<b>Bolt Size</b>	<b>Class 8.8</b>	<b>Class 10.9</b>
5/16	15 FT LB	20 FT LB	6MM	5 FT LB	9 FT LB
3/8	30 FT LB	35 FT LB	8MM	18 FT LB	23 FT LB
7/16	45 FT LB	60 FT LB	10MM	32 FT LB	45 FT LB
1/2	65 FT LB	90 FT LB	12MM	55 FT LB	75 FT LB
9/16	95 FT LB	130 FTLB	14MM	85 FT LB	120 FT LB
5/8	135 FT LB	175 FT LB	16MM	130 FT LB	165 FT LB
3/4	185 FT LB	280 FT LB	18MM	170 FT LB	240 FT LB

• The above specifications are not to be used when the bolt is being installed with a bushing.

**Seat Belts Save Lives, Please Wear Your Seat Belt.**