

GENERAL MOTORS
1988 and Newer, Full-Size 4WD
INSTALLATION INSTRUCTIONS
Kit Part #: C4626K, C4626KS, C4636K, C4636KS



Before beginning the installation, read these instructions and the enclosed driver's "WARNING NOTICE" thoroughly and completely. Also affix the "WARNING" decal in passenger compartment in clear view of all occupants. If any of these items are missing from this instruction packet, do not proceed with installation, but call SKYJACKER® to obtain needed items.

Due to the inconsistency of vehicles when manufactured and the various options available, the amount of actual lift gained by this [lift kit](#) will vary.

PRE-INSTALLATION NOTES:

- A professional mechanic is needed to perform the installation.
- Carefully inspect the vehicle's suspension, steering and driveline systems. Pay close attention to the tie rod ends, pitman arm, idler arms, ball joints and wheel bearing preload. Also check for stress cracks at suspension-to-frame and steering-to-frame. The vehicle must be in excellent working condition, and any worn out parts must be repaired or replaced.
- Read the instructions *carefully* and *study* the illustrations before attempting the installation.
- Compare the parts and hardware against the parts listing to assure that the kit is complete. Separating parts according to the illustrations will be helpful and save time.
- Secure and properly block the vehicle on a level concrete or asphalt surface. It will be important that the vehicle is also level side-to-side when on jack stands.
- Measure the height of vehicle at each tire to check for any existing variances in vehicle's levelness.
- Always wear safety glasses.
- Use caution when cutting is required. The factory undercoating is flammable so have a spray bottle of water in hand.
- Foot pound torque reading are listed on the Torque Specifications chart at the end of the instructions unless specifically stated in an instruction. Apply Loctite retaining compound where specified.

IMPORTANT NOTES:

- Front end realignment is necessary.
- Exhaust modifications may be necessary.
- If larger tires (10% more than stock diameter) are installed, speedometer recalibration is necessary (see GM dealer or Tire Store).
- This lift utilizes the stock torsion bars which normally provide the best ride quality. After the lift is installed, if suspension seems too "soft" heavier rated bars can be installed. If the vehicle is equipped with light duty torsion bars, replacement with heavier rated bars can also increase the front lift if desired. Various torsion bar replacements are available direct from GM dealers.
- This lift is determined from the front while only lifting the rear to a position level with the front.

BOX COMPONENT LISTING:

Item Part#	Description	Qty.	Illustration#
BOX 1 of 3, #C46			
C46-CSA	Centerlink Stabilizer Arm Kit:		
C46-1	Centerlink Stabilizer Arm	1	12
GMCL	Sleeve 1.88" long	2	12
2432	Red Bushing	4	12
58X2SB	5/8 X 2" Shoulder Bolt	2	12
58SAEW	5/8" SAE Flat Washer	2	12
LT100	Loctite Retaining Compound	1	12
C46-2	Front Differential Drop Bracket (Driver Side)	1	8
C46-3	Lower A-Arm Rear Drop Bracket	2	10
C46-4	Rear Cross Member	1	10
C46-5	Front Upper Cross Member	1	12
C46-6	Lower A-Arm Front Drop Bracket	2	12
C46-7	Front Lower Cross Member	1	12
C46-8	Compression Strut Bar	2	13
C46-9	Strut Bar Rear Mounting Bracket	2	13
C46-10	Torsion Bar Cross Member Drop Bracket	2	14
BOX 2 of 3, #C466			
C466-1	Center Steering Link	1	7
C466-2	Front Differential Drop Bracket (Passenger Side)	1	9
C466-3	Upper A-Arm Drop Bracket (Driver Side)	1	11
C466-4	Upper A-Arm Drop Bracket (Passenger Side)	1	---
HB-C466	Hardware Box Consisting of All the Hardware Bags (See page 3 for Hardware Box Contents Listing)	1	---
BOX 3 of 3, #C4626, C4636, C4626S, C4636S			
C462	Idler Arm Spacer Kit for 1988-92 models:		
C462-1	Idler Arm Spacer (2 Bolt)	1	5
12MMX80B	12mm X 80 Bolt - metric	2	5
12MMN	12mm Nylon Insert Lock Nut	2	5
12SAEW	1/2" SAE Flat Washers	4	5
OR			
C463	Idler Arm Spacer Kit for 93 and Newer models:		
C463-1	Idler Arm Spacer (3 Bolt)	1	6
12MMX80B	12mm X 80 Bolt - metric	3	6
12MMN	12mm Nylon Insert Lock Nut	3	6
12SAEW	1/2" SAE Flat Washers	6	6

Item Part#	Description	Qty.	Illustration#
BOX 3 of 3 Continued			
BRAKE LINES			
FBL88S	Front Brake Lines	2	---
38CC	3/8" Cable Clamp	4	---
10X12STS	#10 X 1/2" Self Taping Screws	4	---
SHOCKS			
---"85"	Front Shock w/Red Boot and Mounting Hardware	2	---
---"86"	Rear Shock w/Red Boot and Mounting Hardware	2	---
C46-SP	Differential Skid Plate	1	---
Following is for Box #C4626 and C4636			
RB45	Rear Block 4 1/2"	2	---
916X212X1312U	5/16 X 2 1/2 X 13 1/2" U-bolt	4	---
Following is for Box #C4626S and C4636S			
916X212X1012U	5/16 X 2 1/2 X 10 1/2" U-bolt	4	---

HARDWARE BOX #HB-C466 CONTENTS LISTING:

Item Part#	Description	Qty.	Ill.#	Item Part#	Description	Qty.	Ill.#
HB-C46-ILL8,9				HB-C46-ILL12	Continued		
916X4FTB	5/16 X 4" Bolt	1	8	58X412FTB	5/8 X 4 1/2" Bolt	2	12
916FTN	5/16" Nylon Insert Lock Nut	1	8	58X5FTB	5/8 X 5" Bolt	2	12
916SAEW	5/16" SAE Flat Washer	2	8	58X512CAMB	5/8 X 5 1/2" Special Cam Bolt	2	12
2433	Red Bushing	4	9	58FTN	5/8" Fine Thread Nut	4	12
GMDD	Sleeve 2.39" Long	2	9	58CTN	5/8" Course Thrd Nut (for Cam Bolts)	2	12
HB-C46-ILL10				58SAEW	5/8" Flat Washer	10	12
58X512FTB	5/8 X 5 1/2" Bolt	2	10	BPBN	Bump Stop, Button Shaped	2	12
58X612CAMB	5/8 X 6 1/2" Special Cam Bolt	2	10	38CTSN	3/8" Course Thread Standard Nut	2	12
58FTN	5/8" Fine Thread Nut	2	10	38LW	3/8" Lock Washer	2	12
58CTN	5/8" Course Thrd Nut (for Cam Bolts)	2	10	HB-C46-ILL13,14			
58SAEW	5/8" Flat Washer	6	10	12X3FTB	1/2 X 3" Bolt	2	13
BPPY	Bump Stop, Pyramid Shaped	2	10	12X312FTB	1/2 X 3 1/2" Bolt	4	14
38CTSN	3/8" Course Thread Standard Nut	2	10	12X4FTB	1/2 X 4" Bolt	4	13
38LW	3/8" Lock Washer	2	10	12FTN	1/2" Fine Thread Nut	10	13,14
HB-C46-ILL11				12SAEW	1/2" Flat Washer	20	13,14
12X512FTB	1/2 X 5 1/2" Bolt	6	11	38X412FTB	3/8 X 4 1/2" Bolt	2	14
12FTN	1/2" Fine Thread Nut	6	11	38FTN	3/8" Fine Thread Nut	2	14
12SAEW	1/2" Flat Washer	12	11	38SAEW	3/8" Flat Washer	4	14
12DW	1/2" "D" Washer	6	11	916FTN	5/16" Fine Thrd Nut (for Rear U-bolts)	8	---
GMAA	Sleeve 3.44" Long	2	11	2433	Red Bushing	8	13
GMA B	Sleeve 3.94" Long	2	11	GMSBE	Sleeve 2 3/4" Long	4	13
GMA B-W	Sleeve 3.94" Long w/Welded Washer	2	11	GMSB	Sleeve 1 1/2" Long	2	13
1088H	Eccentric Alignment Kit	1	11	HB-C46-SP	Hardware Bag for Differential Skid Plate		
HB-C46-ILL12				716X112FTB	7/16 X 1 1/2" Bolt	4	---
12X112FTB	1/2 X 1 1/2" Bolt	2	12	716FTN	7/16" Fine Thread Nut	4	---
12FTN	1/2" Fine Thread Nut	2	12	716SAEW	7/16" Flat Washer	8	---
12SAEW	1/2" Flat Washer	2	12				

FRONT DISASSEMBLY:

1. Put vehicle in neutral. Place floor jack under the lower control arm's front cross member and raise vehicle. Place jack stands under frame rails, behind the front wheel wells, and lower the frame onto the stands. Put the vehicle in gear, setting emergency brake, and block rear wheels, in front and behind tires. Remove front wheels and shocks.

WARNING: Be extremely careful when loading or unloading the torsion bars; there is a tremendous amount of stored energy (load pressure) in the bars. Keep your hands and body clear of the adjuster arm assembly and puller tool in case anything slips or breaks.

2. After studying Illustration #1, measure and record the length of the torsion bar adjusting bolt that is exposed below the nut (), and remove the torsion bar adjusting bolt. Apply a small amount of lubricating grease to the puller threads and the puller shaft-to-adjuster arm contact point. Position puller and load adjuster arm until the adjuster nut can be removed from the cross member. With the bar unloaded, slide it further forward into the lower control arm. If the bar seems lodged, use a hammer and punch through the hole in back of the cross member. When the bar shifts forward, the adjuster will fall free.

REPEAT the same procedure on the other side.

3. Remove Torsion Bar Cross Member by removing the 3 bolts per rail that connect it to the frame. It may be necessary to jack up the exhaust to allow clearance for cross member removal.

With the cross member out of the way, the torsion bars can be dislodged from the lower control arms and removed. Mark or separate the bars left and right, since they must be reinstalled on the same side they were removed from.

STEPS 4 THROUGH 8 FOLLOWING ARE PERFORMED ONE SIDE AT A TIME.

4. At driver side front, locate the rubber brake hose that runs from caliper to frame. Pinch it closed with vise grips or a small "C" clamp and detach it from the caliper. Plug or cover the caliper opening to prevent contamination.
5. Remove the 6 bolts that attach CV axle to differential.
6. Detach inner end of tie rod from relay rod/centerlink as shown in Illustration #2.
7. Remove both anti-sway bar drop links which connect bar body to lower control arms. The links' nuts, accessed through the bottom of the arms, are somewhat restricted. It may be necessary to detach the bar at the frame.
8. Place a floor jack under the hub assembly. Remove upper and lower control arm bolts and lower assembly to floor.

REPEAT steps 4 through 8 on the Passenger Side.

9. Detach front driveshaft at differential and secure it out of the way.
10. Remove differential skid plate, if vehicle is so equipped.
11. Unplug differential's electronic coupler and vent hose.
12. Remove the bolt that attached the rear of the differential to lower control arm/differential mount. Using a hack saw or suitable cutting tool, cut off driver side rear wrap around differential bracket as shown in Illustration #3. This allows differential to drop straight down.
13. Position a floor jack under the differential and remove the 3 remaining bolts: 1 bolt - differential to top cross member; 2 bolts - passenger side axle tube to frame. Now lower assembly to the floor.
14. On both sides of frame near upper control arm mounts, unbolt the stock rubber compression travel stops from their steep frame mount brackets and discard. With a torch, carefully trim the steel frame mount brackets from the frame as shown in Illustration #4. Caution - Undercoating is flammable. Grind clean all cutting slag from the trimming performed in previous steps. Paint and undercoat any exposed metal.
15. Referring back to Illustration #2, detach the relay rod/centerlink from the pitman arm and idler arm studs.
16. Detach the anti-sway bar body from the frame. Re-install it reversed or flipped over from the original position.

FRONT INSTALLATION:

17. Install Idler Arm Spacer Bracket between the idler arm and its frame mounting point. The arm is accessed by removing the passenger side inner fender. Install with supplied metric bolts, nuts and washers. For 1988-92 models use bracket kit #C462 and refer to Illustration #5 or for 1993 and newer models, use bracket kit #C463 and refer to Illustration #6.
18. Install the new Center Steering Link #C466-1 as shown in Illustration #7. It should hang straight down. Centerlink Stabilizer Arm #C46-1 does not install at this time, but later in step #26.
19. Attach the driver side Front Differential Drop Bracket #C46-2 to the stock mounting bracket with the existing hardware; finger tight only. See Illustration #8.
20. Attach the passenger side Front Differential Drop Bracket #C466-2 to the frame bracket with the existing hardware. See Illustration #9.
21. Raise the differential into position with a floor jack. Attach the driver side Front Differential Drop Bracket #C46-2 to the top of the differential with the $\frac{5}{16}$ " hardware provided. Refer back to Illustration #8.
22. Loosely attach the passenger side of the axle to the passenger Front Differential Drop Bracket #C466-2 with the existing hardware shown in Illustration #9.

23. Attach Lower A-Arm Rear Drop Brackets (2) #C46-3 to frame using existing bolts in upper hole on bracket as shown in Illustration #10. Be sure the bolts are placed with heads inward toward the axle and threaded end away from the axle to allow extra clearance for the inter CV joint. Install Bump Stop (pyramid shaped) to each #C46-3 using $\frac{3}{8}$ " hardware provided.
24. Install the Rear Cross Member with differential mounting bracket #C46-4 as shown in Illustration #10. NOTE: Special adjusting Cam Bolts allow fine tuning of the Lower A-Arm Brackets so they are aligned perpendicular (90 degrees) to the frame. Tighten all differential mount bolts only. Torque according to spec chart.
25. Install the Driver side Upper A-Arm Drop Bracket #C466-3 into the stock A-Arm location points and onto the frame. Refer to Illustration #11.
- A. Temporarily bolt (or hold tightly) the new upper A-Arm Drop Bracket in place. Use an angle indicator to insure the bracket sits perpendicular (90 degrees) to the frame rail. If it doesn't, grind a little more where the bump stop was cut off. (It is important to have a vehicle sitting level side-to-side on jack stands before starting this project.
- B. Once positioned, use the Upper A-Arm Drop Bracket as a guide to drill the necessary holes in the frame.
- C. Enlarge the two holes in the outer face of the frame to $\frac{3}{4}$ " so that the anti-crush sleeves #GMAA and #GMAB can be inserted into them. The holes on the backside are only large enough for the bolts to protrude, not the sleeves. This way the sleeves are trapped between the inner frame wall and the Drop Bracket preventing the frame from crushing when the bracket's bolts are torqued to specifications during final assembly.
- D. Install the Upper A-Arm Drop Bracket into the original bracket slots using the existing hardware and the hardware provided as shown in Illustration #11.

REPEAT step 25 on the Passenger Side.

26. Bolt the Front Upper Cross Member #C46-5 to the frame using the $\frac{1}{2}$ X $1\frac{1}{2}$ " bolts, nuts and washers as shown in Illustration #12. Then install the Centerlink Stabilizer Arm #C46-1 using the supplied Shoulder Bolts. IMPORTANT: Loctite must be used when screwing the shoulder bolts into the boss on the underside of the Front Upper Cross Member #C46-5 (Illustration #12) and also the Center Steering Link #C466-1 (refer back to Illustration #7).
27. Install Bump Stop (button shaped) onto each of the Lower A-Arm Drop Brackets #C46-6 as shown in Illustration #12 using the $\frac{3}{8}$ " hardware provided. Install the Lower A-Arm Front Drop Brackets #C46-6 to the vehicle's front cross member using the existing hardware as shown in Illustration #12.
28. Attach the Front Lower Cross Member #C46-7 to the lower inside holes of the Lower A-Arm Front Drop Bracket using the special $\frac{5}{8}$ X $5\frac{1}{2}$ " Cam Bolts provided, for dialing in wheel alignment.
29. Starting on driver side, rehang control arms. Both sides install identically. Raise the control arm assembly into position with a floor jack. Install with $\frac{5}{8}$ " hardware at the lower control arm attaching point. Use $\frac{5}{8}$ " bolts pointing rearward on driver side and pointing forward on passenger side as shown in Illustration #12.

Now attach upper control arm to brackets (refer back to Illustration #11). Be sure that the anti-sway bar body is riveted down so it is below the upper control arm's front leg.

Install the new Eccentric Cam Bolt Kit #1088H and adjust bolts to a neutral, or centered position (torque to 75-90 ft. lbs.).

30. Attach the CV axle flange to differential. Use Loctite and torque to 60 ft. lbs.

31. SKYJACKER's® lift incorporates two traction bar-like rods called Compression Strut Bars, #C46-8, that bolt to the rear A-Arm Cross Member #C46-4 and extend to the next chassis cross member. See Illustration #13. These eliminate forward and rearward movement of the differential.

NOTE: Sleeve $\frac{3}{4}$ X 1 $\frac{1}{4}$ " fits inside the cross member, preventing the frame from crushing when the bolts are torqued to specifications.

32. Install the new braided stainless steel front brake hoses. Thoroughly clean all mating surfaces. Make sure old crush washers are removed. Attach new cable clamps to the upper control arm and mount with the self taping screws provided. Position hoses so they don't make contact with any other parts. Hoses must be able to slide unrestricted through the cable clamps.

33. Install the front shock absorbers (Shock box # ending with "85" including 2 shocks stamped with part # ending in "51S"). Torque upper and lower bolts to 48 ft. lbs. Cycle suspension through the full travel cycle and check for adequate clearance between shocks, bump stops and brake hoses. Be sure brake hoses are routed behind shocks.

34. Reinstall the differential vent hose and reconnect the electrical plug.

35. Install the front anti-sway bar drop links. Both sides install identically. Tighten drop link bolt just until bushings swell slightly.

36. Reinstall the front driveshaft. If it does not clear the exhaust crossover pipe, reroute a new section of pipe either above or below the shaft. If necessary, the vehicle can be driven with front shaft completely removed. Torque the shaft to differential bolts to 15 ft. lbs.; torque the shaft to TFC bolts to 74 ft. lbs.

RECHECK CLEARANCES

37. With the vehicle still on the jack stands and suspension hanging at full extension travel, cycle steering lock to lock checking all components for proper operation and clearance. Tighten to required torque specifications per chart at end of instructions.

38. Thoroughly bleed air from brake system.

39. Insert torsion bars into the lower control arms. The rearfacing ends of the bars are now hanging. NOTE: This step is a 2-man operation. Balance the cross member on a floor jack and raise it to mate with the hanging bar ends. Now locate the adjuster arms inside the cross member and onto the torsion bar ends.

40. After the torsion bar cross member is removed and its brackets are flipped so that they mount from under the frame, install the new square tubing Torsion Bar Cross Member Drop Brackets #C46-10 as shown in Illustration #14.

Torsion Bars are marked "left" and "right" and the torsion bar adjusting bolt's exposed length was recorded in step #2 before removal. Now they can be reinstalled to the stock position.

41. Load the torsion bars reversing the sequence of instructions in step #2, again being very careful. Tighten until arms are just clearing nut blocks.

AT THIS TIME GO THROUGH AND TIGHTEN/TORQUE ALL BOLTS TO REQUIRED SPECIFICATIONS ACCORDING TO THE TORQUE CHART AT THE END OF THE INSTRUCTIONS. DO NOT RE-TIGHTEN BOLTS WHERE LOCTITE WAS USED.

REAR INSTALLATION:

1. Place a floor jack under rear axle and raise vehicle. Place jack stands under the frame to support vehicle and remove the rear wheels.
2. With the floor jack, raise the rear axle enough to relieve tension on the shock absorbers and remove them. Disconnect the axle vent hose from the axle housing.
3. Remove the axle U-bolts and lower axle down a few inches. Care should be take because when U-bolts are removed, axle can move freely.

IF INSTALLING A SOFTRIDE® "SYSTEM" WITH NEW REAR SPRINGS, SKIP TO STEP #6.

4. BLOCK INSTALLATION: Place the rear lift blocks in position on the axle making sure the pin in the block is in the hole of the axle housing spring pad. NOTE: The short end of the block goes toward the front of vehicle so that the pinion will be rolled upward toward transfer case.
5. Raise the axle housing up until the pins in the springs align and go into the holes of the blocks. Now skip to step #9.
6. NEW SPRING INSTALLATION: Remove the spring eye bolts and remove original springs from vehicle.
7. Install the new SOFTRIDE® springs supplied with this "SYSTEM" into the original mounts.
8. Raise the axle housing up until the pins in the springs align and go into the holes of the axle housing spring pad.
9. Re-mount the axle to the springs using the existing spring plates and the new U-bolts and nylon lock nuts (tighten these u-bolts to only 85-90 ft.lbs.).
10. Re-connect axle vent hose and install rear shock absorbers (Shock box # ending with "86" including 2 shocks stamped with part # ending with "60S").
11. Install the wheels and lower vehicle down.

12. After rear lift is complete, a final ride height adjustment should be performed. Manually bounce the front and rear of the vehicle to settle in the bars and springs. Evenly adjust the torsion bar bolts until the front of the vehicle is at desired ride height. Each bar may require slightly different adjustment to level vehicle side-to-side, and the bars may settle slightly after vehicle is driven.

NOTE: At maximum ride height, there must still be at least 3/16" of clearance between the bump stop and the front lower control arm. Operating the vehicle with less bump stop clearance will result in a harsh ride and accelerated suspension component wear.

FINAL NOTES:

- After installation is complete, double check that all nuts and bolts are tight. Refer to the following chart again for torque specifications. (Do not retighten nuts and bolts where Loctite was used.)
- If new tires are installed that are more than 10% taller than original tires, the speedometer must be recalibrated for the rear wheel anti-lock brake system to function properly. Contact an authorized GM dealer for details on recalibration.
- With the vehicle on the floor, cycle steering lock to lock and inspect steering, suspension and drive-line systems for proper operation, tightness and adequate clearance. Recheck brake hose/fittings for leaks. Be sure all hoses, including the rear, are long enough.
- Have headlights readjusted to proper settings.
- Have a qualified alignment center realign front end to factory specifications. Be sure vehicle is at desired ride height prior to realignment.
- After realignment, we recommend to tack weld (about 1") the Front and Rear Lower A-Arm Drop Brackets, #C46-3 (Ill. #10) and #C46-6 (Ill. #12), to the lower cross member's mounting points, #C46-4 (Ill. #10) and #C46-7 (Ill. #12), to completely lock in place and hold their alignment. In certain conditions, the alignment of these crossmembers has gotten off requiring another visit to an alignment center. When these pieces are welded as recommended, this will not happen.

SKID PLATE INSTALLATION:

1. SKYJACKER's® lift incorporates a front Differential Skid Plate that bolts to the Rear Lower Cross Member #C46-4 (Illustration #10) and the Front Lower Cross Member #C46-7 (Illustration #12). This locks the front and rear cross members together eliminating forward and rearward movement of cross members and differential, and assist in holding alignment specifications. Furthermore, the skid plate provides protection for the vulnerable differential.

NOTE: Do not install the Differential Skid Plate until after realignment has been performed. Use provided 7/16" bolts with a washer against bolt head and a washer under nut. Align the slotted holes in skid plate with the perpendicular slotted holes in the Lower Cross Members (#C46-4, #C46-7). Insert bolts from bottom through skid plate with nuts on top of cross members, only loosely tighten. Adjust skid plate front to back and side to side to desired position and tighten all bolts. Tack weld the skid plate to lower cross members.

TORQUE SPECIFICATIONS:

3/8" Bolts.....	37 ft.lbs.
7/16" Bolts.....	58 ft.lbs.
1/2" Bolts.....	90 ft.lbs.
9/16" Bolts.....	129 ft.lbs.
5/8" Bolts.....	180 ft.lbs.

ILLUSTRATION #1

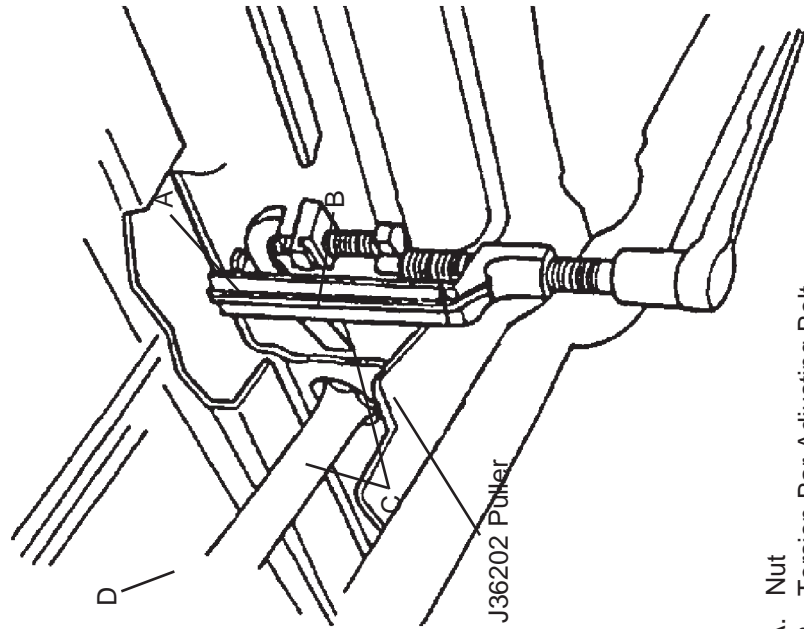

- A. Nut
- B. Torsion Bar Adjusting Bolt
- C. Apply Lubricant at Points to Ease Installation
- D. Torsion Bar

ILLUSTRATION #2

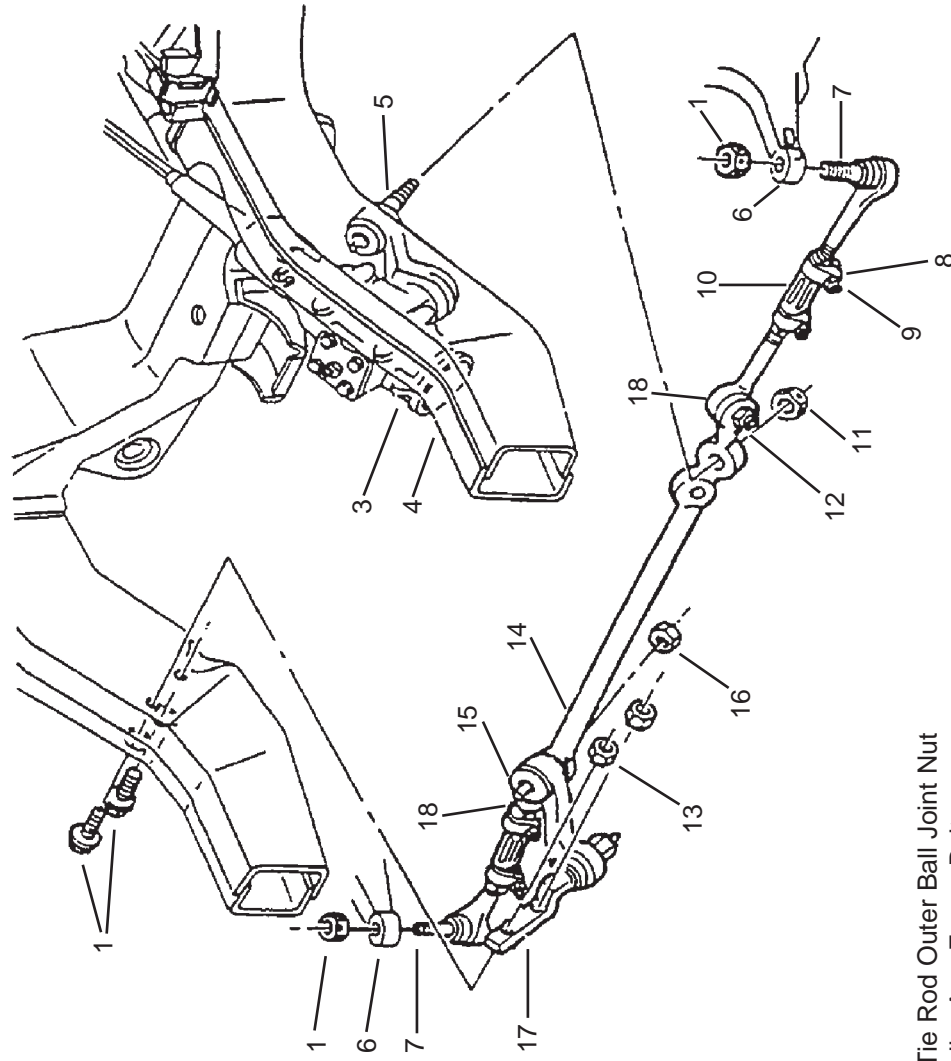

- 1. Tie Rod Outer Ball Joint Nut
- 2. Idler Arm Frame Bolts
- 3. Steering Gear
- 4. Frame
- 5. Pitman Arm Ball Stud
- 6. Knuckle
- 7. Tie Rod Ball Stud
- 8. Clamp
- 9. Clamp Nut
- 10. Adjuster Tube
- 11. Pitman Arm Nut
- 12. Tie Rod Inner Ball Joint Nut
- 13. Idler Arm Frame Nut
- 14. Relay Rod
- 15. Idler Arm Ball Joint
- 16. Idler Arm Ball Joint Nut
- 17. Idler Arm Mounting Bracket
- 18. Tie Rod Inner Ball Joint

ILLUSTRATION #3

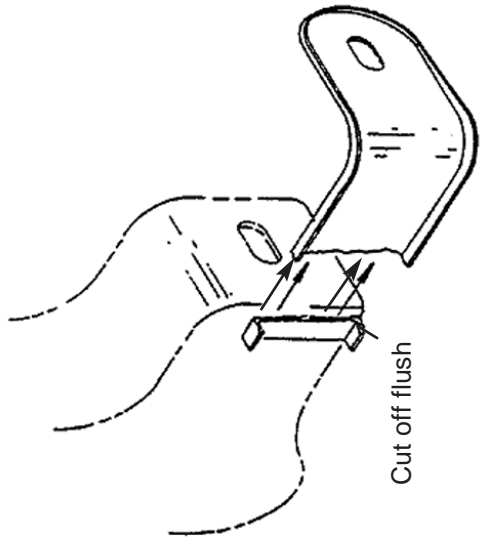

Rear Lower Differential Mount (Driver Side)

ILLUSTRATION #5

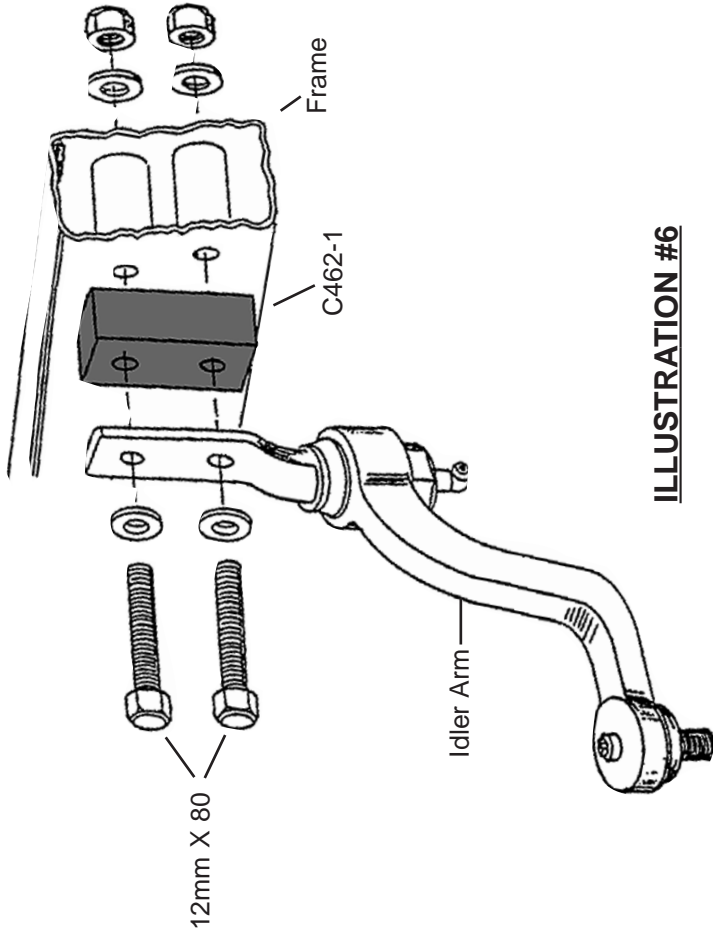

ILLUSTRATION #6

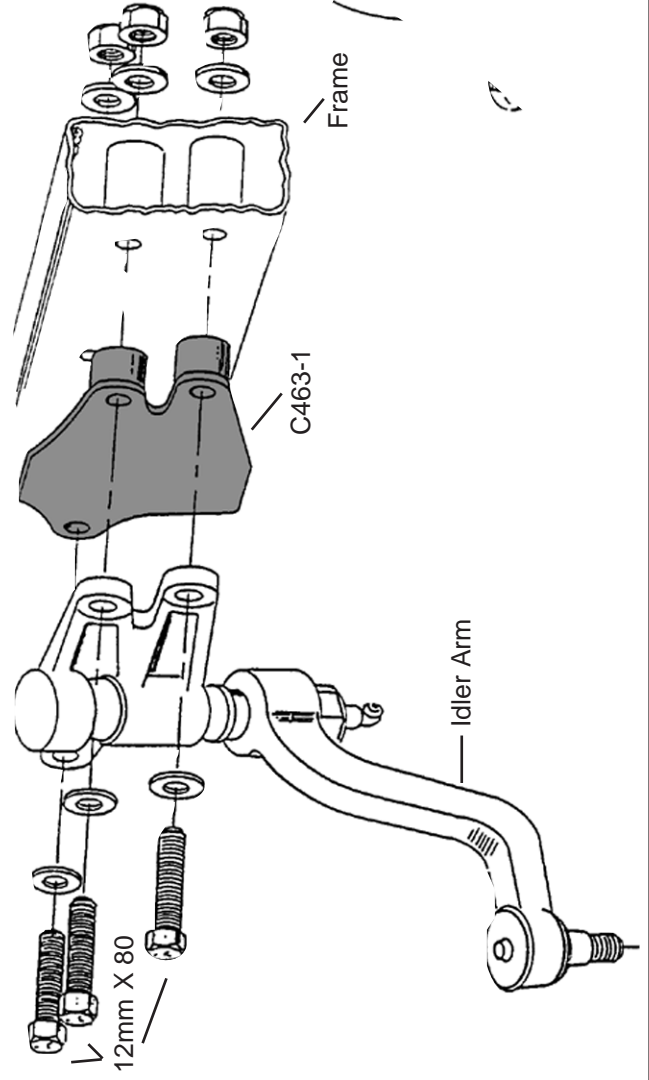

ILLUSTRATION #4

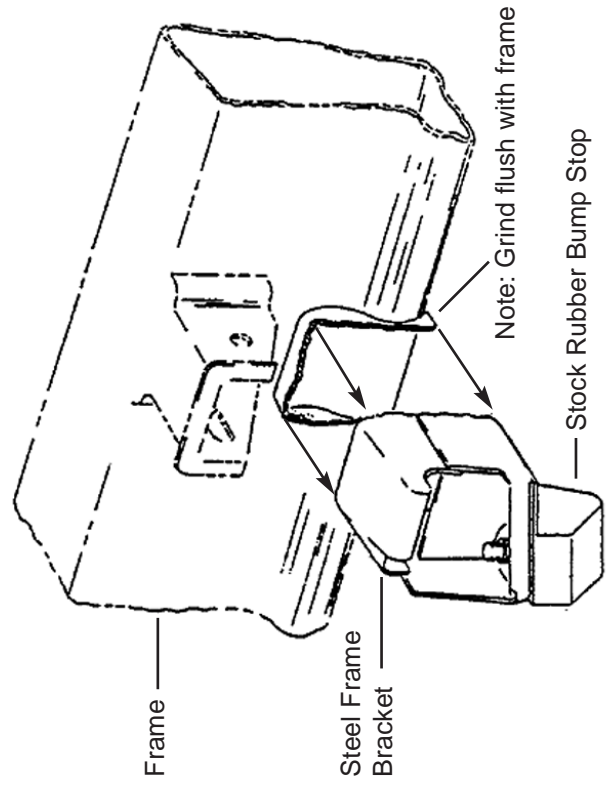

ILLUSTRATION #7

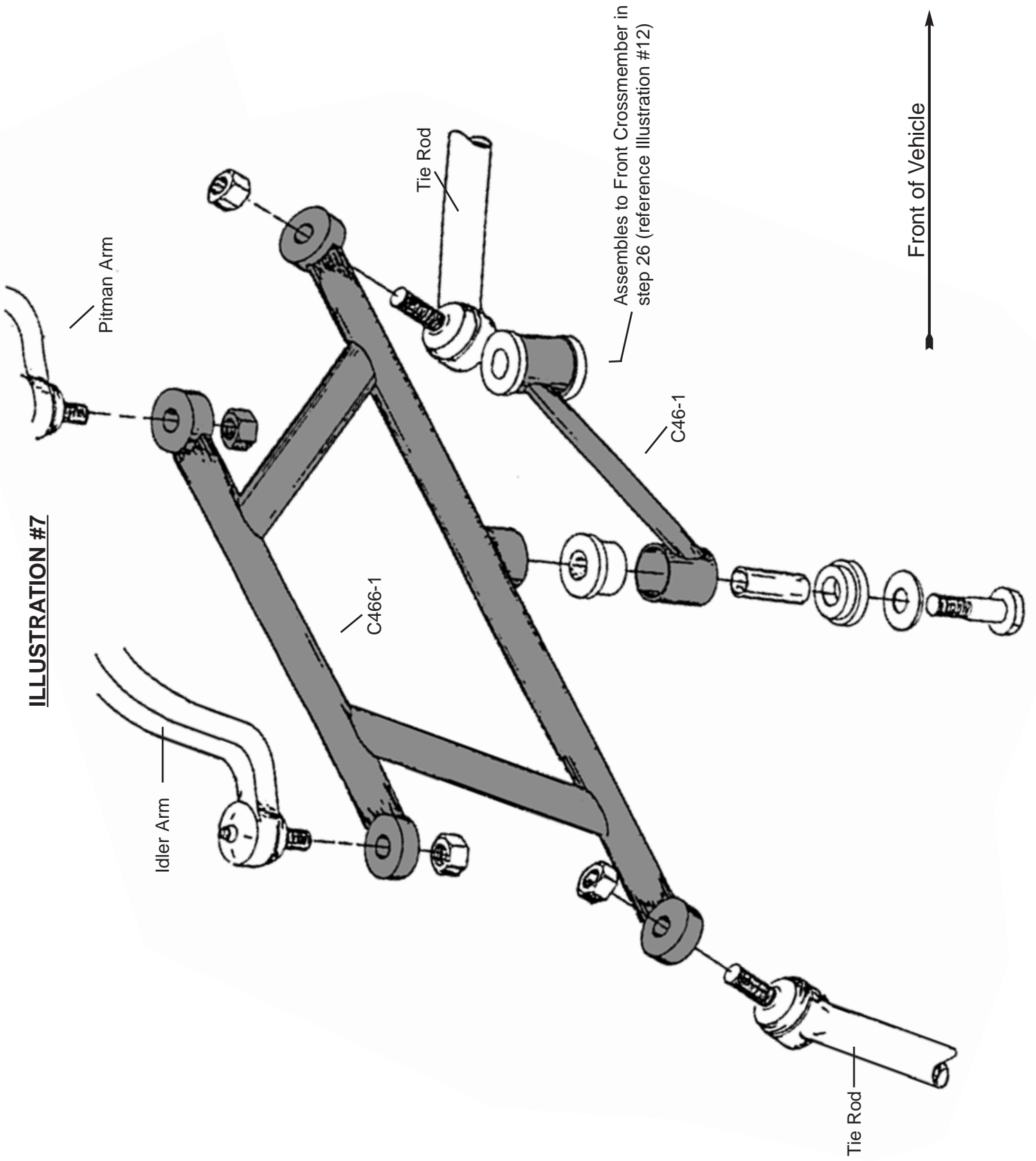

ILLUSTRATION #8

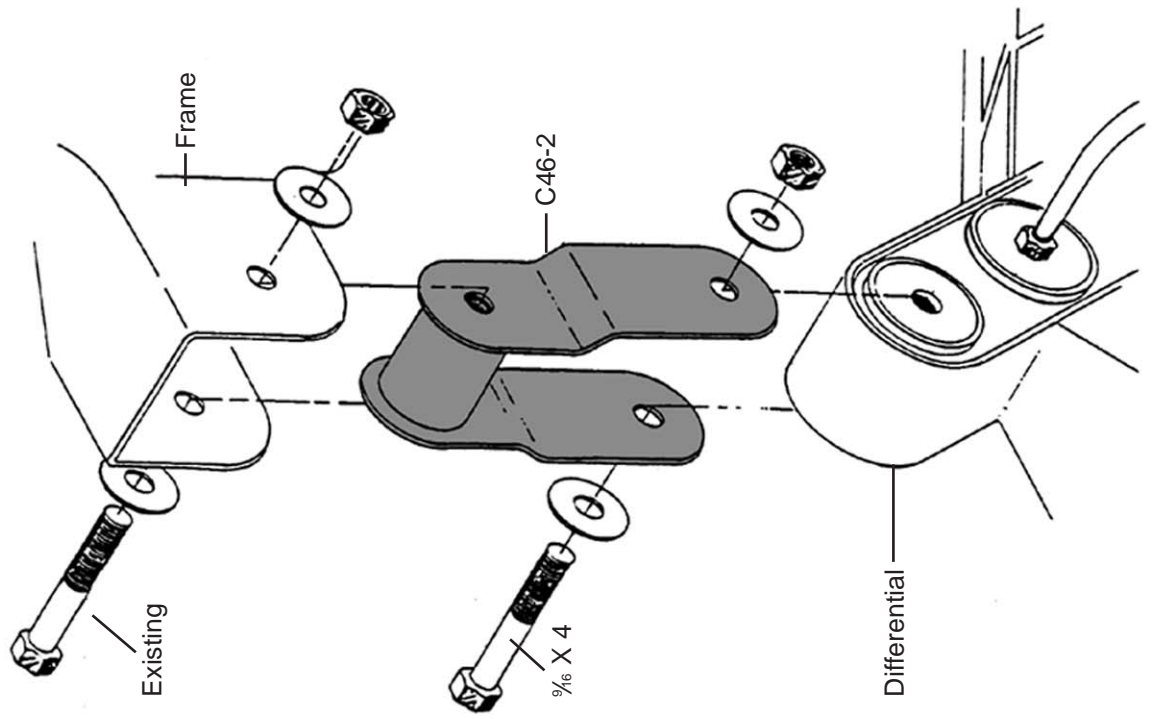

ILLUSTRATION #9

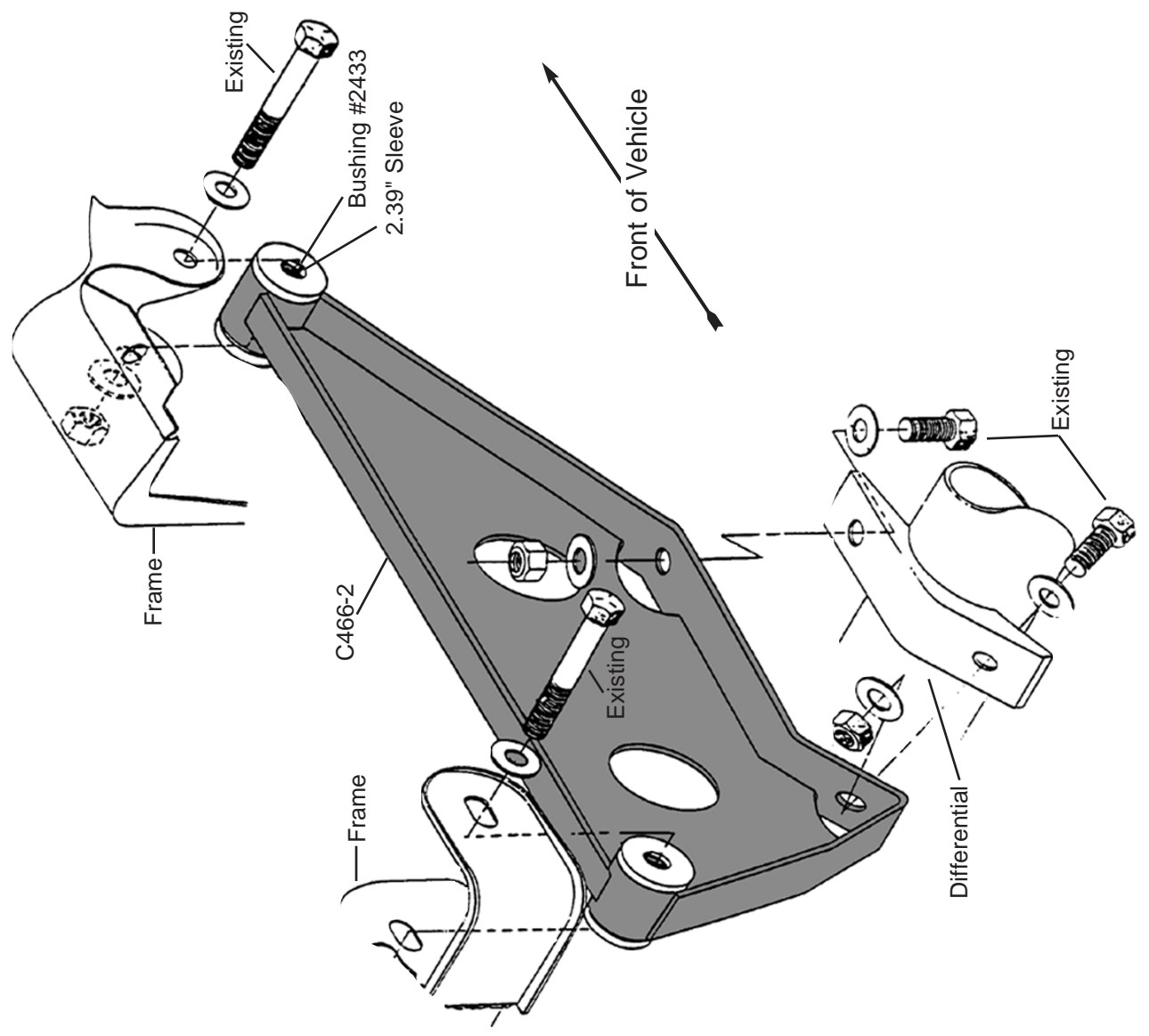

ILLUSTRATION #10

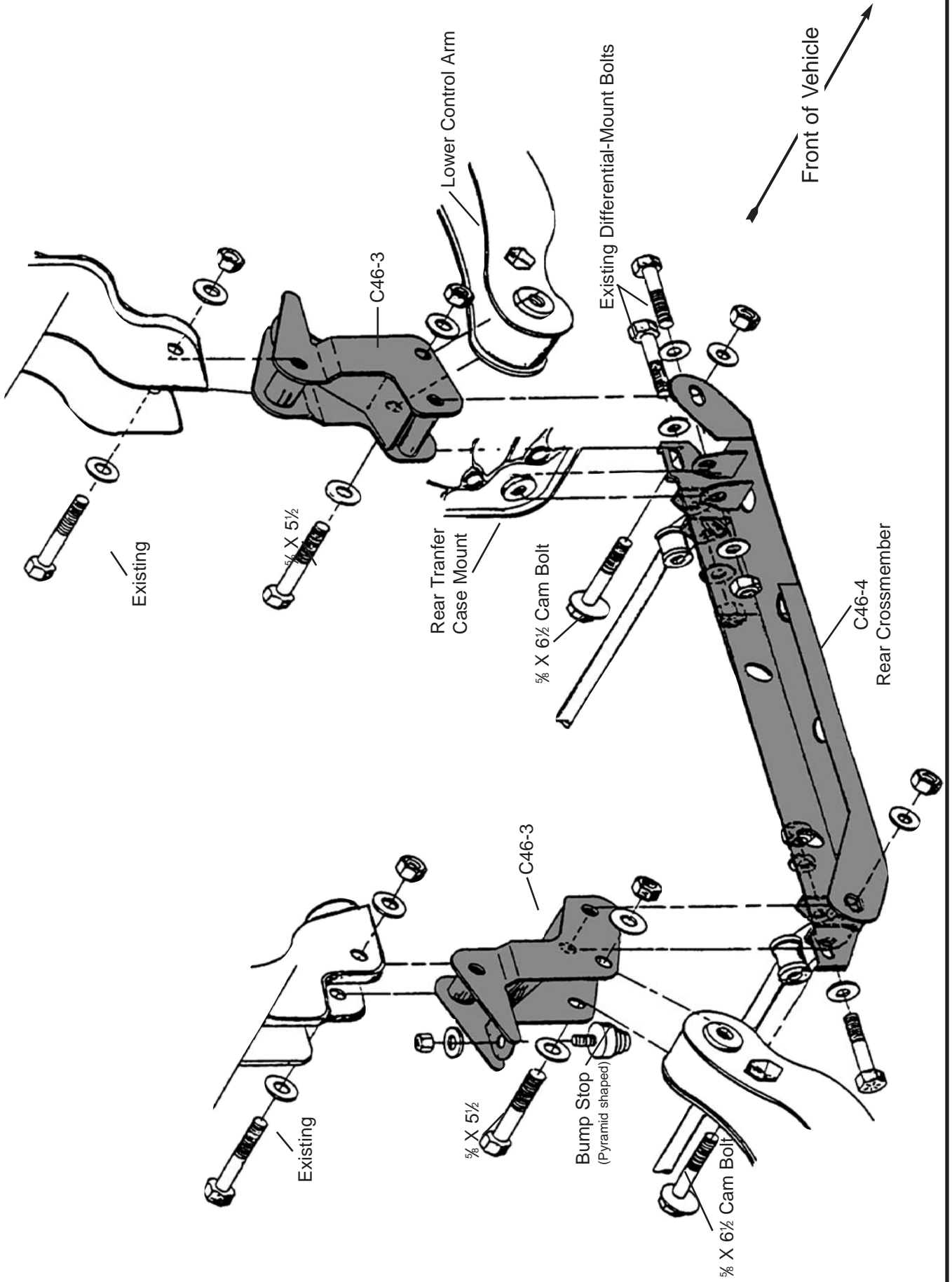

ILLUSTRATION #11

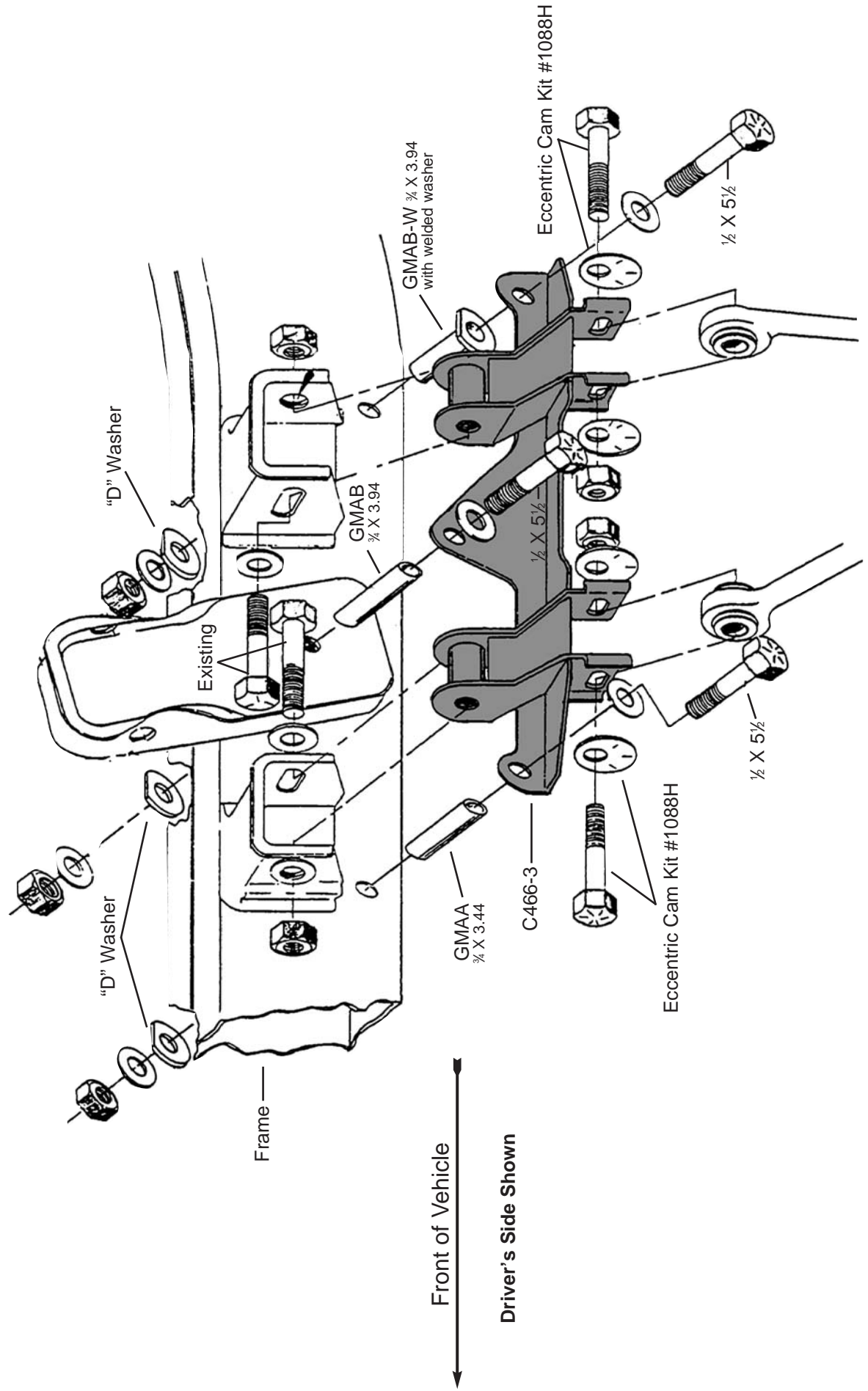

ILLUSTRATION #12

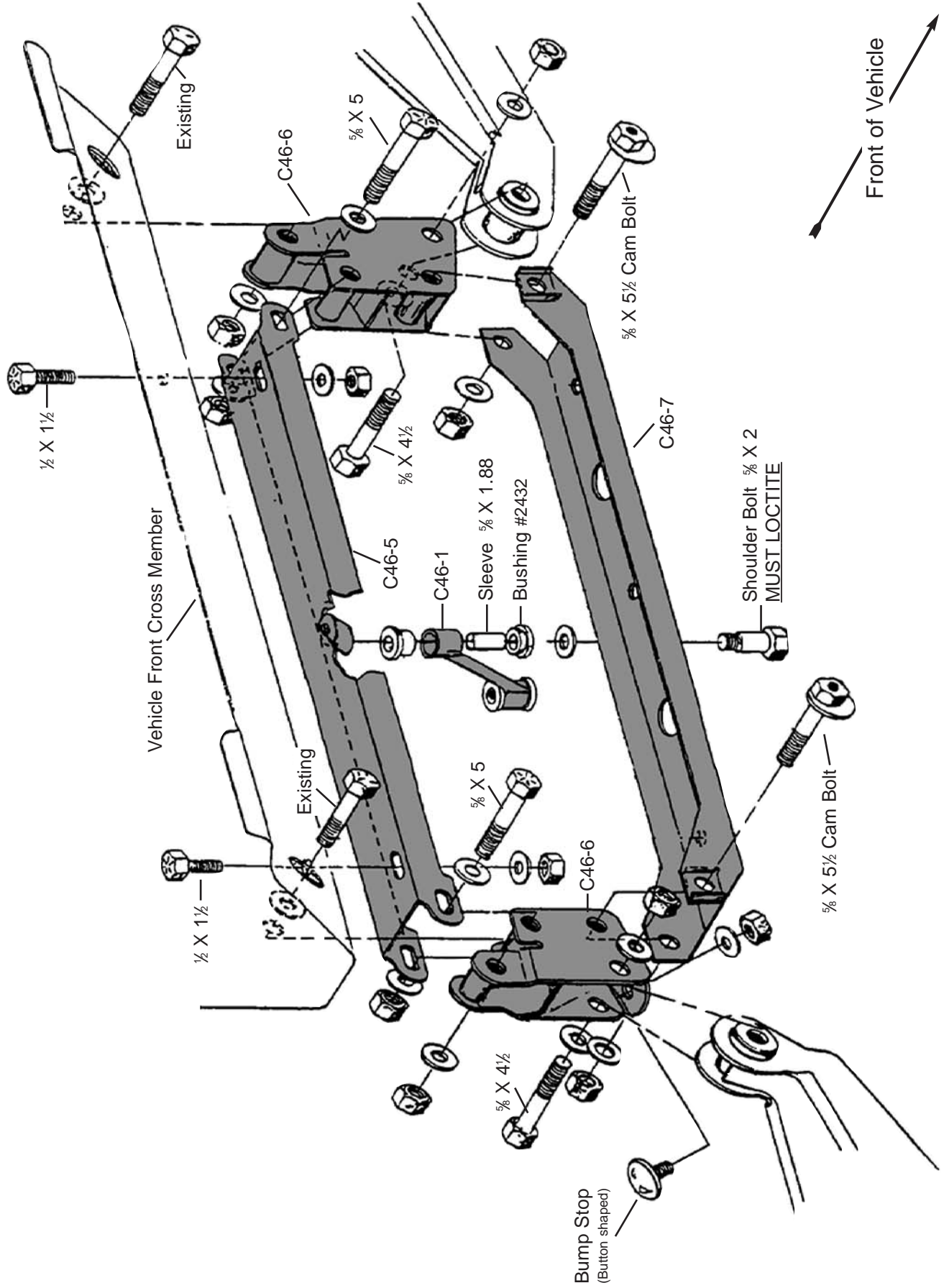

ILLUSTRATION #13

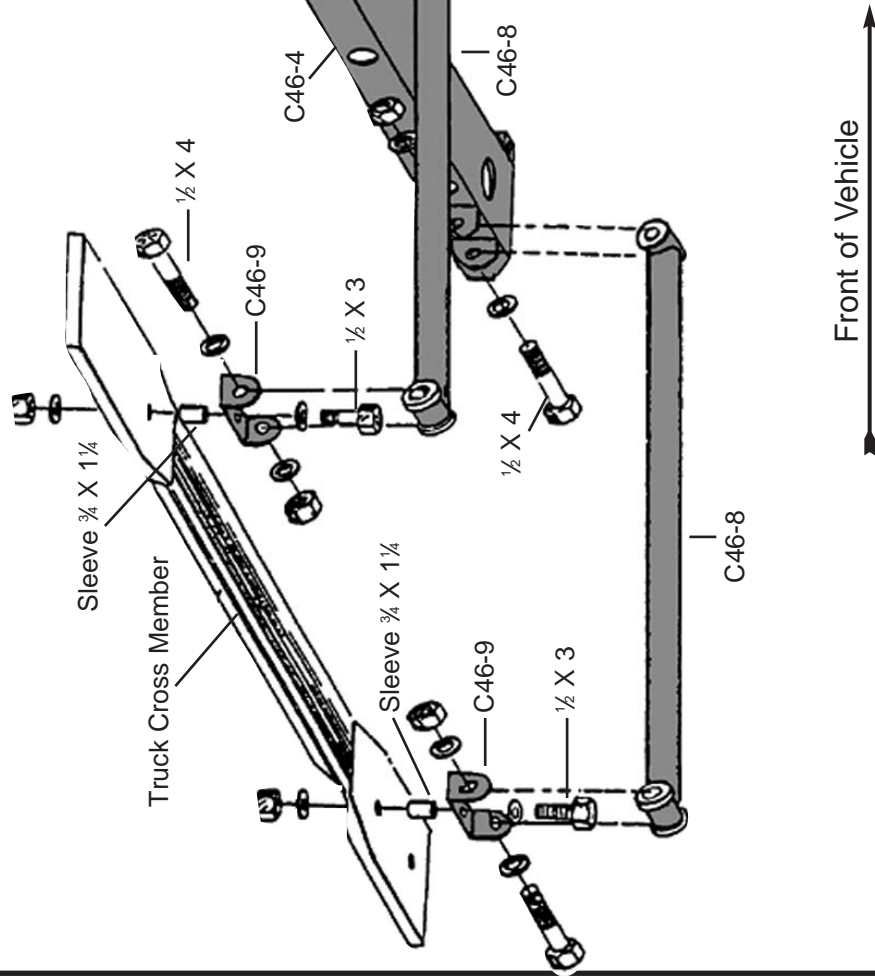

ILLUSTRATION #14

