

'82-'97 RANGER 2 WD  
**CLASS II**  
INSTALLATION INSTRUCTIONS



234R2K-A, 234R2KN-A, 234R2KS-A, 234R2KSN-A  
236R2K-A, 236R2KN-A, 236R2KS-A, 236R2KSN-A

---

Before beginning the installation, read these instructions and the enclosed driver's "WARNING NOTICE" thoroughly and completely. Also affix the "WARNING" decal in passenger compartment in clear view of all occupants.

Due to the inconsistency of vehicles when manufactured and the various options available, the amount of actual lift gained by this [lift kit](#) will vary.

**PRE-INSTALLATION NOTES:**

- A professional mechanic is recommended to perform the installation. Read the instructions *carefully* and *study* the illustrations before attempting installation.
- Check the parts and hardware against the parts list to assure that your kit is complete. The parts and hardware used are high grade and must not be substituted or replaced by inferior ones or failure may result. If any of these items are missing, call SKYJACKER® to obtain needed items. Placing the appropriate hardware with the corresponding brackets will save installation time. This kit is a bolt-on assembly. Do not weld the components to the vehicle, and do not weld anything to the components.
- Check the VEHICLE FRAME for any damage or severe corrosion. If there is any doubt as to the condition of the chassis, have a state approved alignment/frame specialist check the vehicle. If there is any structural damage, do not install this kit.
- Foot pound torque reading are listed on the Torque Specifications chart at the end of the instructions unless stated otherwise in an instruction step. Apply Loctite Retaining Compound on all bolts during installation. A drop on the exposed threads of a bolt before installing the nut will provide an adequate bond. Unless otherwise specified, all bolt should be installed with a flat washer at both ends, Loctite applied, then torqued to specifications.

• **DO NOT USE AN IMPACT GUN TO TIGHTEN ANY OF THE BOLTS.**



• Installation of this kit should take approximately 8-10 hours. Installation by a professional mechanic is recommended. Proper use of the appropriate power tools and the use of a shop hoist or lift can greatly reduce the installation time.

## FRONT INSTALLATION:

1. Block the rear wheels of the vehicle in front and behind the tires. Raise the front of vehicle with a floor jack and support the frame with jackstands. Remove the front wheels and shock absorbers.
2. Remove the cotter pin and nut to disconnect the drag link assembly from the Pitman Arm and let the linkage hang. If your vehicle is equipped with a front anti-sway bar, loosen the bolts that attach the anti-sway bar to the radius arm brackets.
3. Disconnect both front brake lines at the calipers (be careful to save the crush washers as they will be reused if original lines are reinstalled). Hang the open ends of brake lines as high as possible to keep the fluid from draining out. Cover open ends of the lines and calipers to prevent loose dirt from entering the braking system.
4. Place a jack under the passenger axle. Remove the passenger side axle beam bolt and lower axle down. Install the new axle pivot drop bracket (#RHB3262-6, see **illustration #1**) using the hardware supplied. Apply loctite and torque hardware to specifications. Next attach the passenger axle beam to the new drop bracket using the original bolt, and tighten.

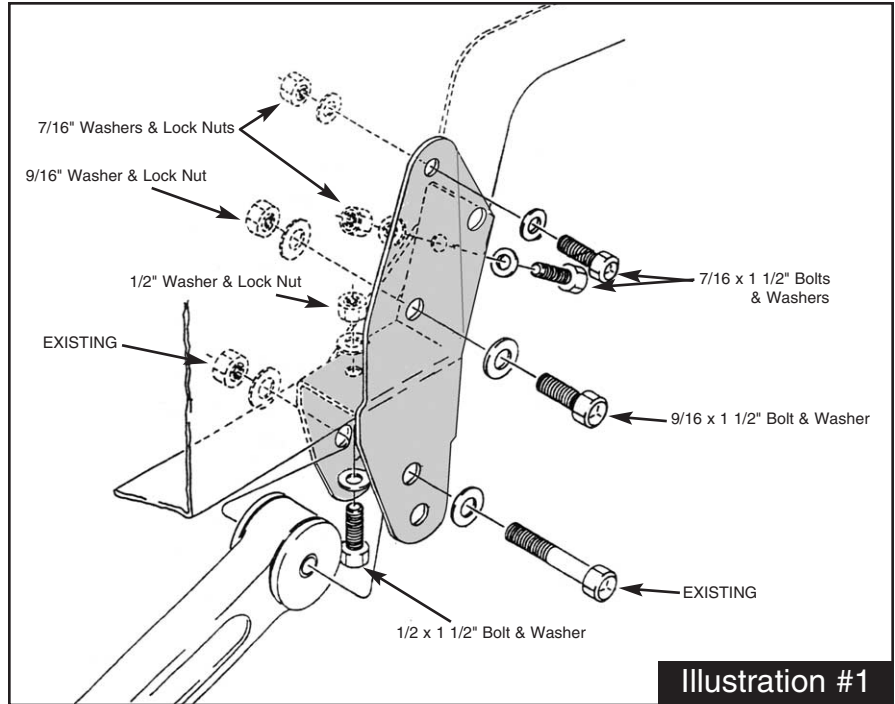

Illustration #1

5. Move jack to the driver axle beam, and remove axle beam bolt from the original bracket (located on the passenger side) and lower down. Remove the original bracket from the front crossmember, saving the hardware. Referring to **illustration #2**, attach new drop bracket (#LHB3262-5) by reinstalling the original hardware.

Next attach the driver axle beam to the new drop bracket using the original hardware, and tighten. Check to be sure all bolts on drop bracket are tightened.

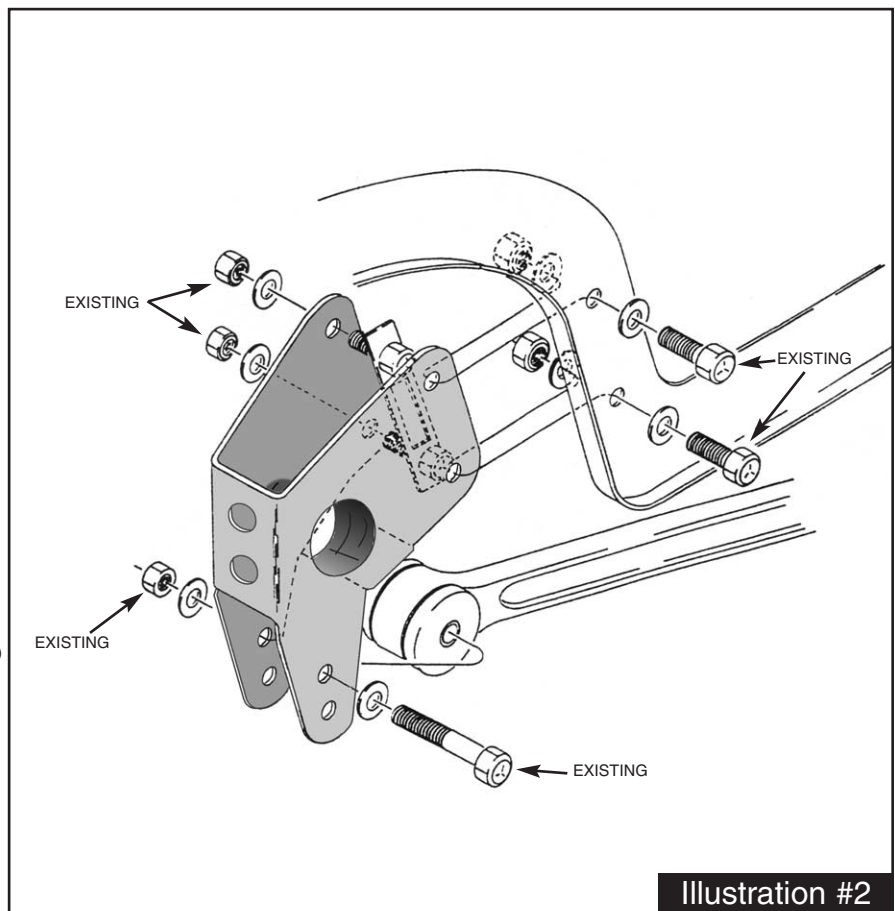

Illustration #2

6. Remove the stock coil springs from both the driver and passenger side of vehicle. Unbolt the stock radius arms, remove the original radius arm frame brackets and remove from front axle housings.

7. Place a jack under the Transmission and raise until it is touching transmission, but do not put a load on it. Remove the rivets and bolts that attach the existing Transmission Crossmember to the frame. If a torch is used to remove the rivets, be careful not to damage the rubber Body Mounts, wiring and hoses located inside the frame.

8. Referring to **illustration #3**, align the driver side radius arm mounting bracket with two of the original holes on side of frame rail, and install  $\frac{1}{2}$  x  $1\frac{1}{4}$ " supplied bolts. Torque these two bolts to specifications. Repeat on passenger side. On the underside hole locations, use the holes in new bracket as a guide and drill a  $\frac{1}{2}$ " hole through frame rail (there are 2 holes on each side to drill). Install  $\frac{1}{2}$  x  $1\frac{1}{4}$ " supplied bolts in these 4 locations, and tighten.

9. Install the new radius arms to the front axles using  $\frac{3}{4}$  x  $8\frac{1}{2}$ " bolts and nuts provided (see **illustration #4**). Install 2" OD shim washers as needed (most 2WD models require 2 per side).

**NOTE:** Be sure to install the correct arm on the correct side with the correct side up (each arm is labeled accordingly).

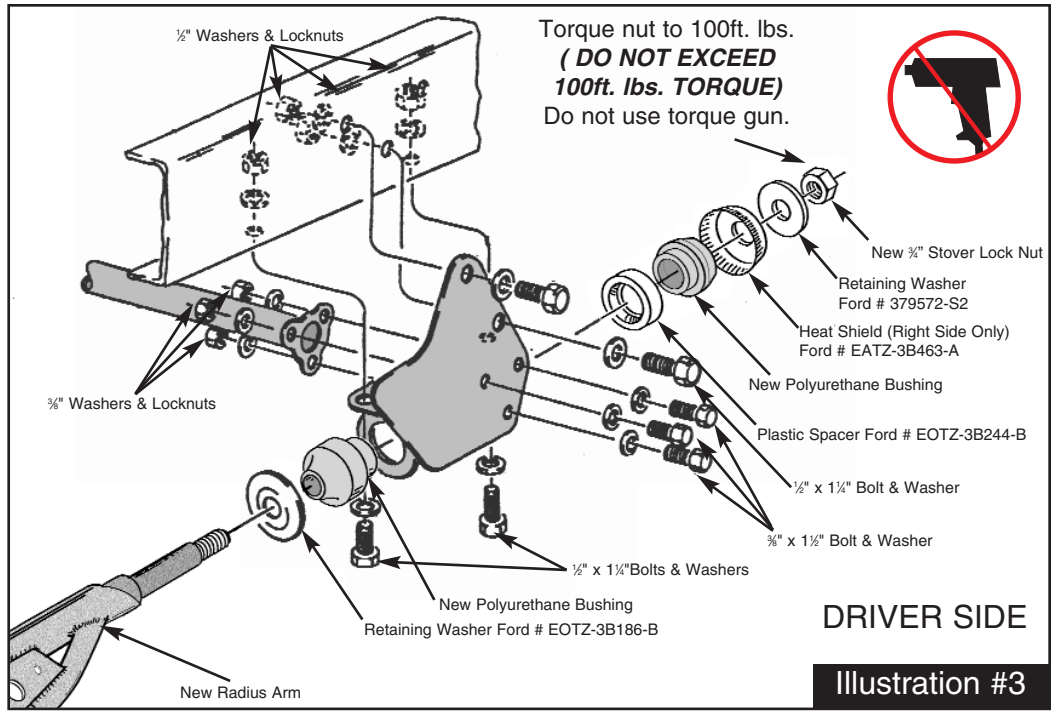

DRIVER SIDE

Illustration #3

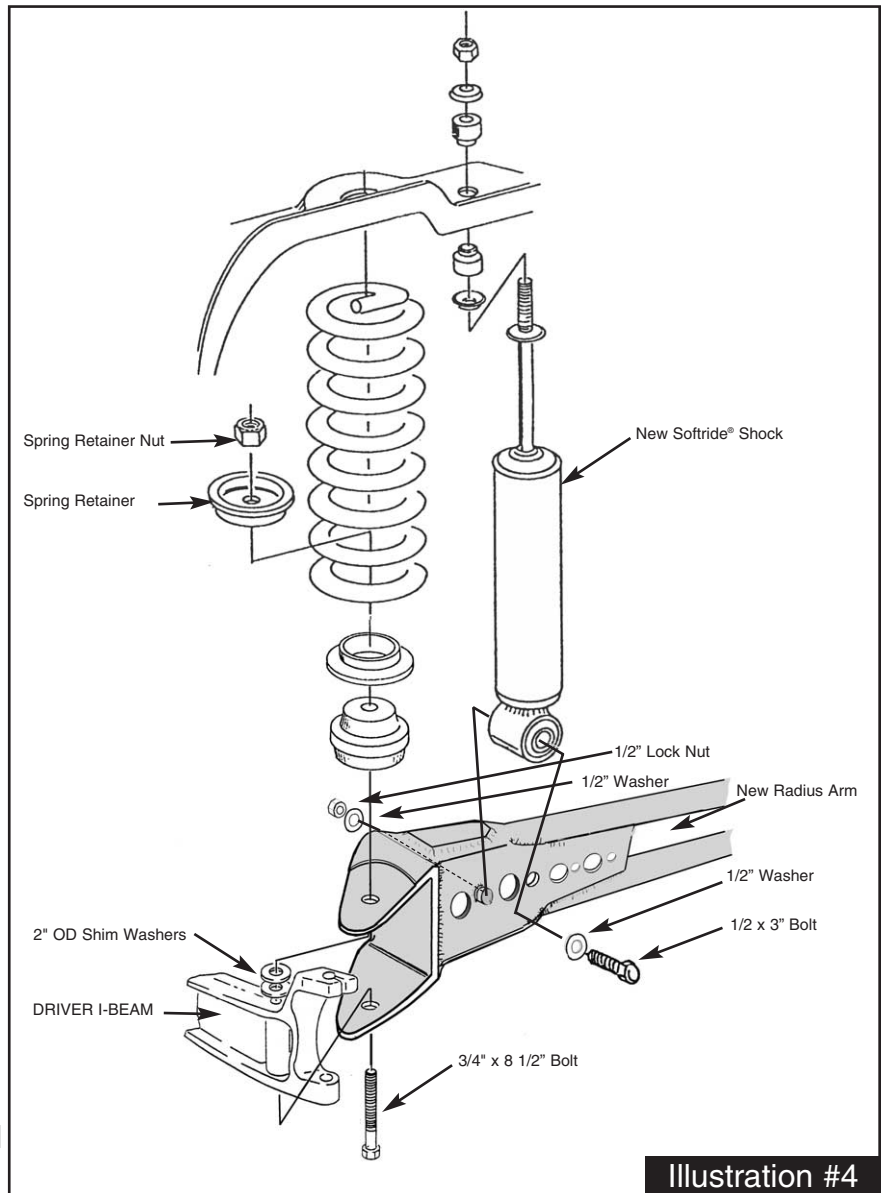
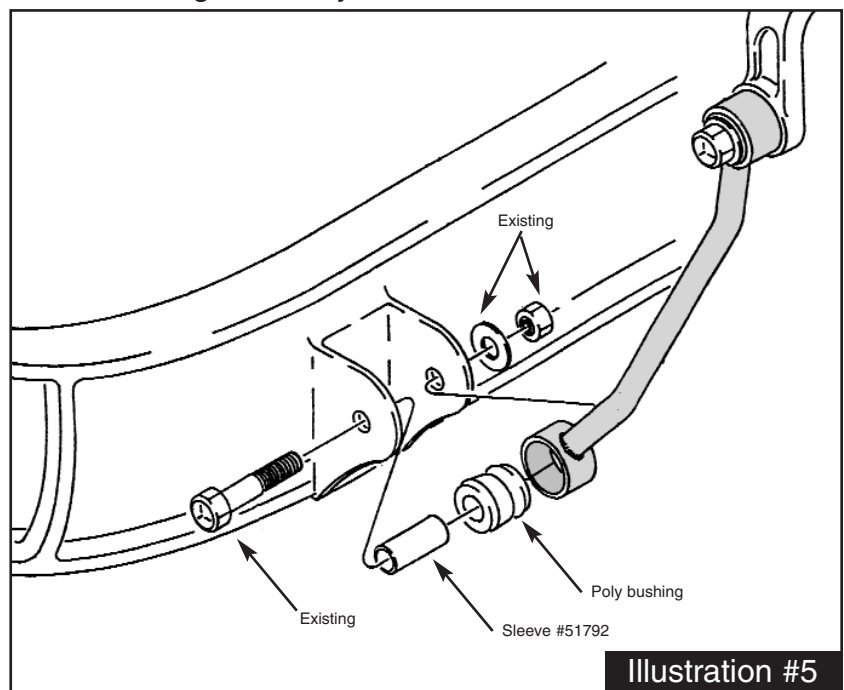

Illustration #4

10. Position the ends of radius arms into the new radius arm mounting brackets using the polyurethane bushings provided along with the original washers and the  $\frac{3}{4}$ " stover nuts provided (as shown in **illustration #3**). Do not fully tighten yet. Using the floor jack, raise axle and radius arms and check clearance on frame. Some models may need clearance at the OEM radius arm washer. Check again to be sure that all radius arm bushings and hardware are installed correctly. Apply loctite and torque radius arm nuts to 100 ft. lbs. ***(DO NOT EXCEED 100 ft. lbs. TORQUE)***. Torque axle beam pivot bolts to 180 - 220 ft. lbs.
11. Position Transmission Crossmember between radius arm mounting brackets so that the upper mount aligns with the existing transmission bracket. Loosely fasten the new trans crossmember to the existing transmission bracket using existing hardware. Now loosely fasten new trans crossmember to each of the radius arm mounting brackets us the  $\frac{3}{8}$  x 1 $\frac{1}{2}$ " supplied bolts. Once all bolts are started, torque per specification chart.
12. Remove the factory bumpstops from the frame. Using a  $\frac{3}{8}$ " drill, enlarge holes and install the bumpstop extensions using  $\frac{3}{8}$ " lock nuts provided. Install new polyurethane bump stops into the new extensions.
13. Referring back to **illustration #4**, install new coil springs. Install new shocks as shown in illustration, using the  $\frac{1}{2}$  x 3" supplied bolts. Tighten shock bolts and stems. Reinstall the front dirveshaft and torque the U-bolts to 12-15lbs.
14. Install the two sway bar extensions, as shown in **illustration #5**, using polyurethane bushings, steel sleeves #51792 and original bolts.
15. Remove the original pitman arm from the steering box using a pitman arm puller. Failure to use the proper tool could result in damage to the steering mechanism. Install the supplied drop pitman arm (#FA400, for power steering models) into position, noting indexing marks, and tighten. Reconnect the drag link assembly to the new pitman arm.
16. Install the appropriate length brake lines at this time (also available from SKYJACKER®). Bleed the brakes to remove any air from the lines according to factory recommendations. Reinstall axle vent hose.
17. Reinstall the tires and lower vehicle to ground.
18. Cycle the steering left and right from lock to lock and check for any binding or interference. There should be a minimum of 1.0" of clearance between the tires and the radius arms at full lock. If there is less than 1.0", check to make sure you have the proper wheel offset and size. If necessary, the steering stop bolts may be adjusted out to 1.25", maximum.



**Illustration #5**

## **REAR INSTALLATION:**

19. Place a floor jack under rear axle and raise vehicle. Place jack stands under the frame to support vehicle and remove the rear tires and shock absorbers.
20. Remove the axle U-bolts and lower axle down a few inches. Care should be take because when U-bolts are removed, axle can move freely.
21. **BLOCK INSTALLATION:** Place new blocks (tallest end toward rear bumper) under the original rear springs. Raise axle up being sure that block pins are aligned and that spring bolt is aligned in block. Install and tighten new rear u-bolts evenly (torque u-bolts 90-95 ft.lbs.). Install rear shock absorbers, tires, remove jack stands and lower vehicle down. Skip to Final Notes.
22. **NEW SPRING INSTALLATION:** Remove the spring eye bolts and remove original springs from vehicle. Install new springs with the long end of spring toward the rear bumper (also, thick end of bottom wedge shim goes toward the rear bumper, if equipped).
23. Raise the rear axle back up, aligning spring pins into axle housing. Install and tighten new u-bolts evenly (torque u-bolts 80-85 ft.lbs.). Install rear shock absorbers, tires, remove jack stands and lower vehicle down. Skip to Final Notes.

## **FINAL NOTES:**

- Before driving the vehicle, check to make sure the brakes are operating properly and need no further bleeding.
- Inspect the components for tightness and for any damage periodically, especially after off-road use.
- After installation is complete, double check that all nuts and bolts are tight. (Do not retighten nut and bolt where Loctite was used.) Check to ensure there is adequate clearance between All rotating, mobile and fixed members.
- Rotate driveshafts and check for interference at differential yoke and cardan joint. If necessary, lightly dress casting(s) and/or U-joint tabs in order to eliminate binding.
- On models with a rear carrier bearing, if a driveshaft vibration is present, the carrier bearing or its crossmember must be lowered.
- Ensure there is adequate clearance between exhaust and brakelines, fuel lines, fuel tank, floor board, and wiring harnesses. Check steering gear for interference and proper working order. Inspect brakelines for damage and adequate clearance. Test brake system.
- Have headlights readjusted to proper settings.
- Front end realignment is necessary so have a *qualified* alignment center realign front end to factory specifications.

## **TORQUE SPECIFICATION CHART:**

5/16" Bolts .....	13 Ft.-Lbs.	Spring Retainer - Upper Spring Seat .....	13-19 Ft.-Lbs.
3/8" Bolts .....	35-37 Ft.-Lbs.	Radius Arm - Axle Beam (stud & bolts) ....	180-220 Ft.-Lbs.
7/16" Fine Thread Bolts.....	55-58 Ft.-Lbs.	Lower Spring Retainer - Radius Arm .....	30-70 Ft.-Lbs.
1/2" Fine Thread Bolts.....	85-90 Ft.-Lbs.	Pitman Arm - Steering Gear Nut .....	170-228 Ft.-Lbs.
1/2" Rear U-bolts .....	80-85 Ft.-Lbs.		
9/16" Fine Thread Bolts.....	115 Ft.-Lbs.		