



1966-1979 F-150/Bronco 4WD Suspension Lift Installation Instructions



- Safety Glasses
- Metric / Standard Wrenches & Sockets
- Drill / Assorted Drill Bits
- Floor Jack
- Jack Stands
- Measuring Tape
- Torque Wrench

Before beginning the installation, thoroughly & completely read these instructions & the enclosed driver's WARNING NOTICE. Affix the WARNING decal in the passenger compartment in clear view of all occupants. Please refer to the Parts List to insure that all parts & hardware are received prior to the disassembly of the vehicle.

Make sure you park the vehicle on a level concrete or asphalt surface. Many times a vehicle is not level (side-to-side) from the factory & is usually not noticed until a lift kit has been installed, which makes the difference more visible. Using a measuring tape, measure the front & rear (both sides) from the ground up to the center of the fender opening above the axle. Record this information below for future reference.

Driver Side Front: _____ Passenger Side Front: _____

Driver Side Rear: _____ Passenger Side Rear: _____

Important Notes:

- If larger tires (10% more than the stock diameter) are installed, speedometer recalibration will be necessary. Contact your local Ford dealer or an authorized dealer for details.
- After installation, a qualified alignment facility is required to align the vehicle to the OEM specifications.

Front Installation:

1. Raise the front of the vehicle & support securely with jack stands under the frame behind the radius arms & block the rear tires / wheels. Remove the front tires / wheels & OEM shocks. On lifts of 6" or more it will be necessary to remove the OEM drag link assembly from the OEM pitman arm & lower the assembly.
2. Place a floor jack under the front differential. With light pressure applied from the jack, remove the OEM shocks, lower retaining nut & washer at the bottom of the coil spring, & bolt strap at the top of the coil spring. Lower the jack & remove both OEM coil springs. **Note:** The OEM coil springs will come out at the top by twisting.
3. Install the new Skyjacker coil springs & start the bolts in the bottom of the new coil springs. (Do not tighten at this time.) Fit the new coil springs into the upper spring cradles & raise the axle with a floor jack. Install & tighten the bolt straps at the top of the new coil springs. Tighten the bottom bolts in the new coil springs. Be sure all bolts & nuts are tight at this time.
4. Install the new Skyjacker front shocks, front tires / wheels, & lower the vehicle to the ground.
5. If installing a new Skyjacker drop pitman arm, refer to those instructions at this time.

Rear Installation:

6. Raise the rear of the vehicle & support securely with jack stands & block the front tires / wheels. Remove the rear tires / wheels, OEM shocks, & u-bolts. **Caution:** The rear axle will now be free to move, so support securely on a floor jack. If installing the "SYSTEM" with new Skyjacker rear leaf springs, continue to Step # 7, if not installing new rear leaf springs, proceed to Step # 8 or # 9.
7. **Rear Leaf Springs:** Unbolt & remove the OEM rear leaf springs & bolt up the new Skyjacker rear leaf springs with the long end of the new rear leaf spring towards the rear bumper of the vehicle. **Note:** On new rear leaf springs with the bottom degree shim, the thick end of the shim must also be towards the rear bumper of the vehicle. For added strength, the tie bolts in the new rear leaf springs have been increased from the OEM 3/8" diameter to a new 7/16" diameter Grade 8. Therefore on Bronco models or when removing the OEM block on an F150, the spring seat on the axle pad will need to be drilled to 5/8" to accept the new larger tie bolt head. On F150 vehicles with the new rear leaf springs installed, you may leave the rear of the vehicle sitting high as it was OEM. If you would rather the rear of the vehicle sit level with the front, remove the OEM rear blocks. Proceed to Step # 10.
8. **Rear Add-A-Leafs:** Place a C-clamp around the OEM rear leaf spring pack within approximately 6" of each side of the OEM tie bolt & remove the tie bolt from the rear leaf spring pack. If the new part number to be installed is R3120(s) follow Step # 8A or if R300(s) follow Step # 8B below, then proceed to Step # 10.

- 8A. Open up the band clips on each end of the OEM rear leaf spring, if so equipped. Remove the C-clamps slowly. Place the new Skyjacker add-a-leaf into the rear leaf spring pack so the leaves progress from longest down to shortest (usually installed under the top main leaf). Insert the new Skyjacker tie bolt from the bottom going through the OEM overload then the leaf spring pack. Retighten the C-clamps to help compress the leaf spring pack, tighten the new tie bolt & rebend the band clips back over the rear spring leaves.
- 8B. Install the new Skyjacker add-a-leaf between the OEM rear leaf spring pack & OEM bottom overload leaf. Insert the new Skyjacker tie bolt from the bottom going through the OEM overload, the new add-a-leaf & leaf spring pack. Tighten the nut & remove the C-clamps from the leaf spring pack.
9. **Rear Blocks:** F150 models-Install the new Skyjacker rear lift blocks with the tall end toward the rear bumper of the vehicle, between the OEM rear leaf springs & OEM rear blocks. (This means the new rear lift block will be installed on top of the OEM rear block.) BRONCO models-Install the new Skyjacker rear lift blocks with the tall end toward the rear bumper of the vehicle, between the OEM rear leaf springs & OEM wedge (78-79 models).
10. Using a floor jack, raise the axle to the new rear leaf springs. Be sure the tie bolts and/or block pins align in the proper holes. Install & tighten the new Skyjacker u-bolts, shocks, & rear tires / wheels & lower the vehicle to the ground. **Note:** Some models may require the OEM rear u-bolt plates to be drilled in order to accommodate the new Skyjacker larger heavy duty 9/16" diameter u-bolts.

LENGTHENING THE OEM TRACK BAR

The OEM track bar needing to be lengthened is the solid bar going from the driver's side frame of the vehicle down to the axle housing. The length will vary from one vehicle to another. Remove the frame end of the OEM track bar & lower down. Center the body over the front tires / wheels by turning the steering wheel to move the body. Raise the OEM track bar & you will now see that it is too short. Measure the distance between the center of the OEM track bar hole & the bracket. The OEM track bar will require to be lengthened that amount. Scribe a line on the OEM track bar before cutting so it can be realigned. Taper the OEM track bar in a V-groove so it can be welded 100% through. Use cold roll steel for the extension piece, since the OEM track bar is high quality mild steel.

Note (A)
Scribe a line along straight side of Bar. Realign after welding Extension Piece.

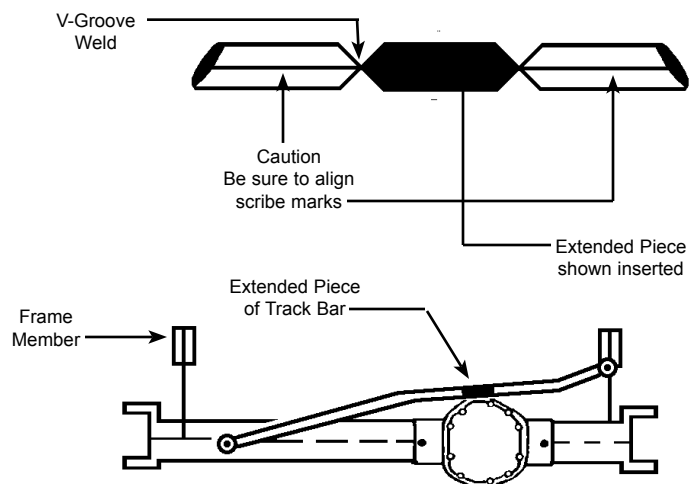
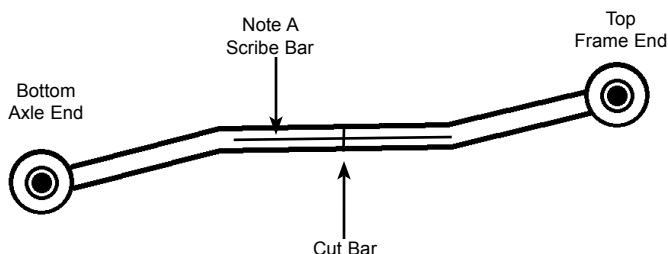

Notes:

Once a lift is installed on this vehicle, correction of the caster alignment is necessary. This can be corrected with "C" bushings &/or radius arm drop brackets. Toe-in adjustment may also be required. 9" lifts with a 4 speed manual transmission may require 4 degree C bushings (Part # CB40), radius arm drop brackets Part # RAB40 (67-77 Bronco) or RAB47 (78-79 Bronco & 66-79 F150), & front & rear drive shafts to lengthened.

Final Notes:

- After the installation is complete, double check that all nuts & bolts are tight. Refer to the following chart for the proper torque specifications. (Do not retighten the nuts & bolts where thread lock compound was used.)
- With the vehicle placed on the ground, cycle the steering lock to lock & inspect the steering, suspension, brake lines, front & rear drivelines, fuel lines, & wiring harnesses for proper operation, tightness, & adequate clearance.
- Have the headlights readjusted to the proper settings.
- Have a qualified alignment center align the vehicle to the OEM specifications.
- After the first 100 miles, check all hardware for the proper torque & periodically thereafter.

TORQUE SPECIFICATIONS					
<u>INCH SYSTEM</u>			<u>METRIC SYSTEM</u>		
Bolt Size	Grade 5	Grade 8	Bolt Size	Class 8.8	Class 10.9
5/16	15 FT LB	20 FT LB	6MM	5 FT LB	9 FT LB
3/8	30 FT LB	35 FT LB	8MM	18 FT LB	23 FT LB
7/16	45 FT LB	60 FT LB	10MM	32 FT LB	45 FT LB
1/2	65 FT LB	90 FT LB	12MM	55 FT LB	75 FT LB
9/16	95 FT LB	130 FTLB	14MM	85 FT LB	120 FT LB
5/8	135 FT LB	175 FT LB	16MM	130 FT LB	165 FT LB
3/4	185 FT LB	280 FT LB	18MM	170 FT LB	240 FT LB

- **The above specifications are not to be used when the bolt is being installed with a bushing.**

Seat Belts Save Lives, Please Wear Your Seat Belt.