

SHIFNOID WIRING DIAGRAM

FOR a B&M PRO RATCHET with SN5070 SOLENOID KIT

IF YOUR RPM SWITCH OR TIMER SUPPLIES "NORMALLY OPEN GROUND"
(SHIFNOID OR MSD) USE THIS DIAGRAM

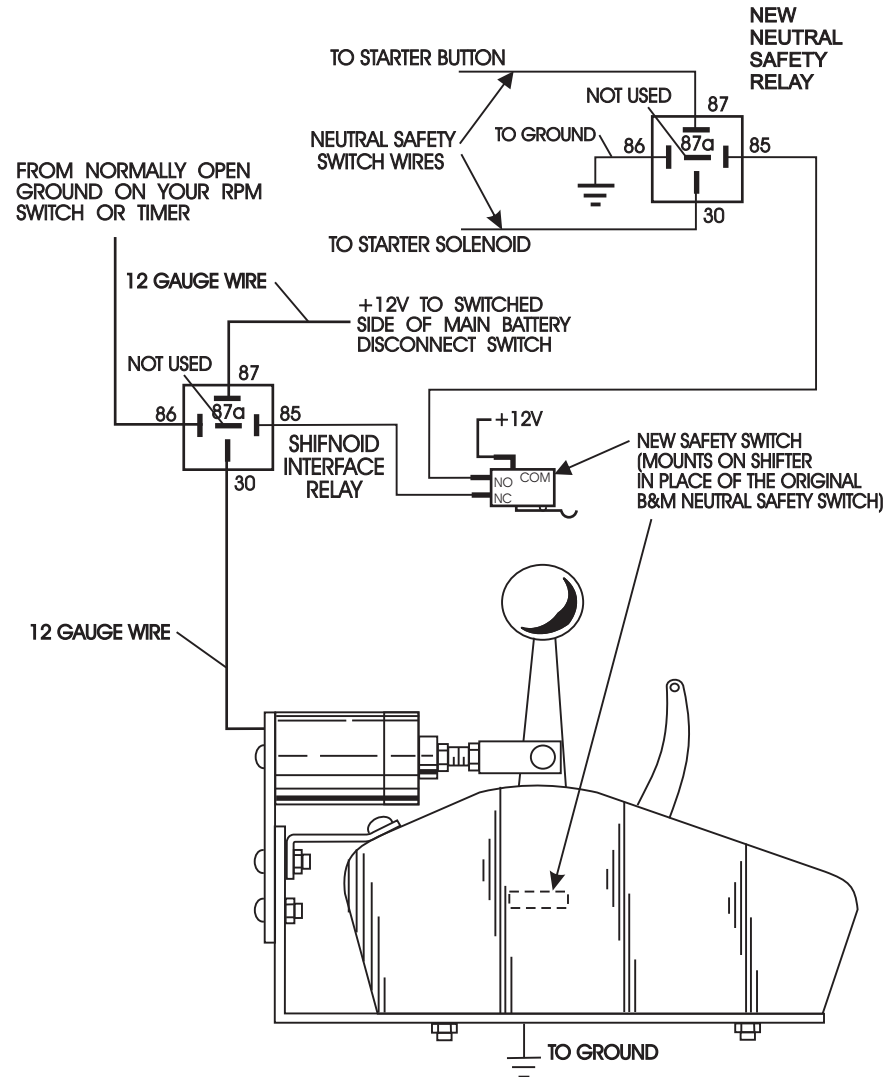

IF YOUR RPM SWITCH OR TIMER SUPPLIES "NORMALLY OPEN +12V"
(DEDENBEAR OR DIGITAL DELAY) USE THIS DIAGRAM

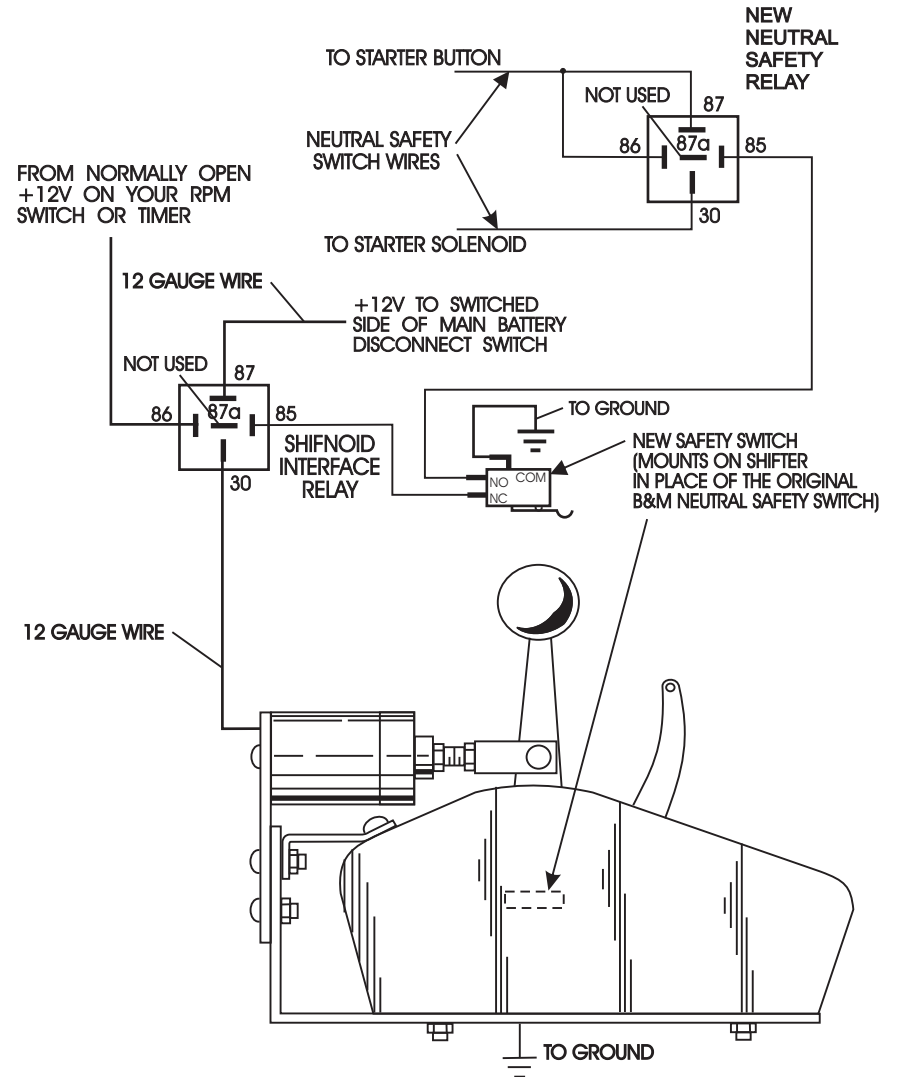

MODIFYING YOUR "B&M" 80842 PRO RATCHET SHIFTER TO INSTALL SHIFNOID SN 5070 SHIFT KIT

Drill a $\frac{7}{16}$ " hole, $\frac{7}{16}$ " from the back edge of the shifter lever, $1\frac{1}{2}$ " above the lever guide as shown. This hole is oversize to allow for an arc accommodation. The correct placement of this hole is critical to the operation of the solenoid. Please be precise. Dimensions shown are with cover removed. It is recommended you center punch the correct spot and start with a small drill bit and work up to the final size.

The handle of the shifter extends below the base of the shifter housing. It is common to have the chrome handle rub against the SHIFNOID base plate. This is only noticeable when you shift the shifter lever toward the front or rear. Before installing the shifter, please check for this condition. If it exists, sand or grind a small amount off of the shifter lever so that it clears the SHIFNOID base plate when the shifter is in ALL positions. Depending on when you bought your shifter, this step may not be necessary.

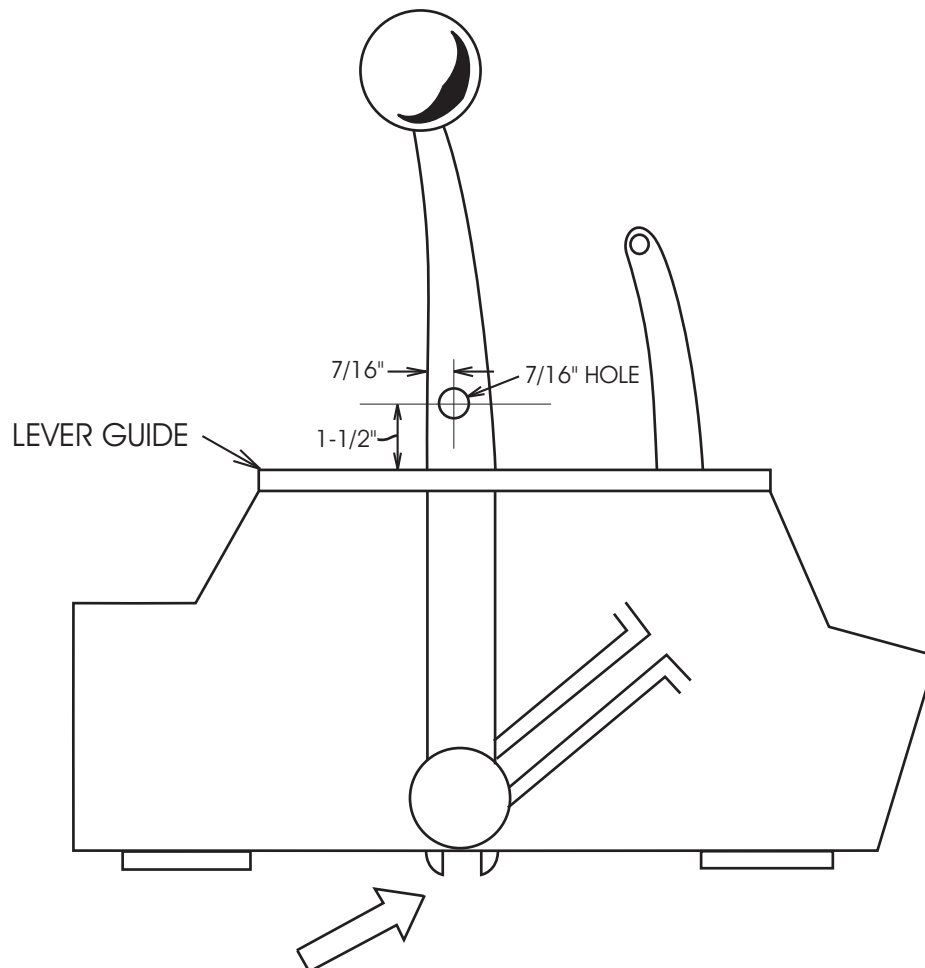

INSTALLATION INSTRUCTIONS PART #SN5070

“SHIFNOID” REVERSE PATTERN 3 SPEED KIT FOR B & M PRO RATCHET™ SHIFTER

MODIFYING YOUR “B&M SHIFTER

If you are installing this unit on your “B&M Pro Ratchet”, the shifter has to be modified according to the Modifying Diagram provided. This consists of drilling a 7/16” hole in the shifter lever 1 1/2” above the lever guide and 7/16” from the back edge of the lever, and cutting the shifter handle base for clearance. (See diagram)

MOUNTING THE UNIT

The SHIFNOID mounting bracket is drilled for the “B & M Pro Ratchet” three speed shifter only. The holes in the bottom of the L shaped bracket align with the holes in the right side of the shifter. Mount the L shaped bracket between the shifter and floor or mounting surface, with the bolts supplied with your shifter. Either shim or do not bolt down the left side. Stop at this point to wire the switches that go under the aluminum cover. Please read “WIRING THE UNIT” before installing the aluminum cover. After wiring, install the shifter cover supplied with your shifter with the front screw only. Mount the SHIFNOID solenoid and bracket it came attached to, to the L shaped bracket with the bolts provided, through the two holes provided in each bracket. Before installing the top nut, attach the small support bracket on the top bolt and nut. Bolt the other end of this support bracket to the hole in the rear of cover and attach with the bolt supplied with you shifter. Align the solenoid by adjusting the position of the two main brackets in relationship to one another and tighten nuts. The solenoid must be aligned so that there is no binding when the shifter is moved through its complete cycle. This alignment is important for the smooth operation of this kit. Adjust the length of the plunger with the clevis and threaded rod making sure that you are putting your transmission fully in each gear. The object is to adjust the plunger and clevis assembly to it’s longest possible length, still allowing the shifter to travel far enough to complete each shift. When finished, the entire plunger, lock washer and jam nut should be inside the solenoid when the shifter handle is pulled back. Verify that the handle is all the way back to confirm you are fully completing the shift.

WIRING THE UNIT

Follow the wiring diagram supplied. If your RPM switch or Timer supplies Normally Open Ground” connect the trigger wire from your device to post 86 on the SHIFNOID interface relay. Supply post 87 with 12V+, through a 12 gauge wire. Connect post 85 to the N.C. terminal on the new safety switch. Connect post 30 to the solenoid.

If your RPM switch or Timer supplies a “Normally Open 12 V+” connect the trigger wire from your device to post 86 on the SHIFNOID interface relay. Supply post 87 with 12V+, through a 12 gauge wire. Connect post 85 to the N.C. terminal on the new safety switch. Connect post 30 to the solenoid.

There is a new safety switch supplied with this unit. Install this switch in place of the original B & M Neutral safety switch. This switch MUST be used so the shifter cannot be electrically activated while in Park or Neutral. This switch must be correctly adjusted before you install your aluminum cover.

This switch must make and brake contact as the shifter moves between Park and Neutral and any Forward or Reverse gear. Do NOT over tighten this switch. If you already had the B&M shifter installed in your car, you had two wires going to the original neutral safety switch. Remove these wires from that switch and move them to the new "neutral safety relay", post 87 and 30, as shown. If you are installing the shifter and shift kit for the first time, you will create a neutral safety circuit by interrupting the wire that runs between your starter button and your starter solenoid. The new neutral safety relay is placed in that line, one wire going to post 87, the other to post 30, as shown

DO NOT CONNECT THE SOLENOID DIRECTLY TO AN RPM SWITCH. ALWAYS USE THE SAFETY SWITCH AND THE INTERFACE RELAY. AN UNINTENTIONAL SHIFT COULD INJURE SOMEONE AND THE RPM SWITCH MAY BE DAMAGED.

WARNING

Be Prepared! If you are using an RPM switch or Timer, you must be aware that at any time RFI (Radio Frequency Interference) could stop your RPM switch or Timer from activating. This in turn could cause your automatic shifter to not activate and you will need to shift manually. Always pay attention to your car and be prepared to manually shift or lift off of the accelerator to prevent the over revving of your engine. One of the best ways to protect your engine under these conditions is to also install some type of over rev control so that the engine cannot reach an RPM beyond it's safe limits. Please read the enclosed information on RFI included with this kit.

TROUBLESHOOTING AND TECHNICAL SUPPORT

SHIFNOID SN5070 ELECTRIC SHIFT KIT

PROBLEM: SOLENOID WILL NOT ACTIVATE

SOLUTION: To test the system, turn all power on. There is no need to run the engine. Place the shifter in 1st gear. Locate Post 86 on the INTERFACE relay.

IF YOUR RPM SWITCH SUPPLIES NORMALLY OPEN GROUND - Carefully and momentarily, touch a wire from a good chassis GROUND to Post 86. This should activate the solenoid and the shifter should pull into 2nd gear. The solenoid should activate anytime you GROUND Post 86 on the INTERFACE relay IF the shifter is in gear.

IF YOUR RPM SWITCH SUPPLIES NORMALLY OPEN POWER (12 volts) - Carefully and momentarily touch a wire from 12 volts to Post 86. This should activate the solenoid and the shifter should pull into 2nd gear. The solenoid should activate anytime you POWER Post 86 on the INTERFACE relay IF the shifter is in gear. If this test is OK, the SHIFNOID system is functioning properly and you will need to look at the activating system. (RPM Switch, timer, or push button).

If the solenoid tries to pull, but cannot pull all the way into 2nd gear, see next Problem.

If the solenoid still does not activate at all and you have a RPM Switch that supplies NORMALLY OPEN GROUND your next step is to check for power at Post 86 on the INTERFACE relay. The shifter must be in 1st, 2nd, or 3rd gear for this test. If power is not at Post 86 when the shifter is in gear, the 3-prong safety switch needs adjusted or the power to the common on the 3-prong safety switch is not there. (Anytime the shifter is in Park or Neutral, Post 86 on the interface relay should be dead, no voltage. Anytime the shifter is in gear, Post 86 should be hot).

If you have a RPM switch that supplies NORMALLY OPEN POWER your next step is to check for ground at Post 85 on the INTERFACE relay. The shifter must be in 1st, 2nd, or 3rd gear for this test. If a ground is not at Post 85 when the shifter is in gear, the 3-prong safety switch needs adjusted or the ground to the common on the 3-prong safety switch is not there. (Anytime the shifter is in Park or Neutral, Post 85 on the interface relay should be dead (not grounded). Anytime the shifter is in gear, Post 85 should be grounded).

PROBLEM: THERE ISN'T ENOUGH POWER TO PULL THE SHIFTER HANDLE ALL THE WAY BACK

SOLUTION: To determine why the solenoid can't pull the shifter handle fully into the next gear, you must first determine if the solenoid cannot pull the handle or if the load on the solenoid is too great. Without proper testing equipment, the only way to determine this is by process of elimination. Many times, there are multiple problems that total up to an inoperable system. You must verify and fix them all to correct this condition. Rarely, is this problem caused by only one thing. Please follow all steps listed below.

STEP ONE: To confirm that the solenoid has all it's power, verify that the wire connected to post 87 on the interface relay is 12 gauge or larger, and runs directly to a suitable power source, (i.e. master battery disconnect switch). This power source must be sufficient to supply a 25 - 30 amp draw. Do not connect this wire to any terminal or point that supplies other electrical devices. Confirm that the wire from Post 30 on the interface relay to the solenoid is 12 gauge or larger.

STEP TWO: The solenoid gets its ground from the SHIFNOID bracket. The SHIFNOID bracket typically receives a sufficient ground by bolting it to your floor. Many times, because of paint, powder coating, or mounting (such as a pinned in pedestal), the bracket will not receive a sufficient ground. This would cause a solenoid to receive insufficient amperage to have full power. If in doubt, add a ground wire to your shifter or SHIFNOID bracket and to a good chassis ground.

STEP THREE: Alignment of the Plunger and Clevis Assembly

The plunger (the gold barrel shaped piece), must slide in and out of the solenoid smoothly; regardless of the shifter handle position. Any binding between the plunger and the solenoid will cause excessive drag. To correct this problem, loosen the 2 5/8" bracket bolts that hold the solenoid bracket to the main bracket. Then, align the solenoid and retighten the bolts. A common problem of plunger binding is drilling the hole in the shifter handle in the wrong place or too small. It should be a full 7/16" to allow for arc accommodation.

STEP FIVE: The Length of the Plunger and Clevis Assembly

To achieve maximum power, the object is to adjust the plunger and clevis assembly to its longest possible length, yet still allow the shifter to travel far enough to complete each shift. The plunger should bottom out inside the solenoid when the shifter handle is pulled back. When doing this adjustment, verify that the shifter handle is all the way back. If the handle is not all the way back when the plunger bottoms out, you will not complete the shift. This could cause possible transmission damage.

The preceding five steps will verify that the SHIFNOID system is up to full power.

Next, you must check for an excessive load beyond what the SHIFNOID is capable of activating. If the SHIFNOID system is producing full power and the handle still will not move correctly, follow the steps listed below.

STEP ONE: Verify that the bottom of the B & M shifter handle is not hitting the SHIFNOID bracket when the shifter handle is being moved forward or back. Some B & M Pro Ratchet shifters must have the bottom of the shifter handle shortened to avoid this. See "Modifying your B & M Shifter" in your instructions.

STEP TWO: The B & M Pro Ratchet shifter cable routing is critical. The Pro Ratchet is prone to a cable bind directly in front of the shifter, where the cable typically goes through the floor. There must be no bend or pressure on the first or last several inches of the cable. See "B & M Instructions" for cable mount attachment warning. Cable routing must include large gradual bends. Any tight bends or kinks will create a load greater than the SHIFNOID can pull.

STEP THREE: Transmission Detent Spring

Many transmission builders install aggressive detent springs. Alone, this is rarely a problem, but it can aggravate other problems. If all other methods have been exhausted, it is possible that you may have to compensate for this. Unless you are an experienced transmission mechanic, we do not suggest that you alter the detent spring. Instead, we suggest an external "helper spring". A simple "hardware store" spring attached to the shift arm of the transmission, pulling toward third gear, will solve the problem. This spring must stretch all the way to park, yet still be pulling on the shift arm from 1st to 2nd and 2nd to 3rd, helping the transmission in the critical areas. This step is rarely required, but handy when all other solutions have been exhausted. IT IS commonly used in unique applications, such as excessively long shifter cables.

PROBLEM: THE SOLENOID WILL ONLY SHIFT FROM 1ST TO 2ND

SOLUTION: The solenoid is a simple electrical appliance. It can only be turned on and off if it is activated or deactivated. It cannot stay on or turn off without your RPM switch or timer activating it. There are two possible reasons for this problem.

STEP ONE: The most common scenario is a car whose RPMs do not drop sufficiently between shift points. Most RPM switches require a drop of 400 to 500 rpms to turn off. Example: this means that if you shift at 6000 rpms, and because of clutch wear, tire spin, or your converter not locked up, the drive train (everything from the flex plate back), cannot drag the engine down because of slippage. The rpms do not drop below 5500 and your RPM switch, in effect, tells the solenoid to stay on. This will result in the solenoid pulling the shifter handle from 1st to 2nd and locking back. Shifting before your converter is locked up is the most common problem. Converter stall speed is rarely where advertised. The following simple test may confirm this. Raise your shift point as high as you safely can. If this solves the problem, consider tightening the converter. If the problem persists, raising your shift point may cause transmission clutch slippage to worsen, if they are worn, and may even increase the problem. Some types of racing, such as mud, dirt or sand drags, result in tire spin that cannot be eliminated. When this is the case, special electronic controllers are available to solve the problem. Please ask your SHIFNOID dealer for assistance.

STEP TWO: Another common problem is the electrical solenoid shifting from 1st to 2nd, the engine dropping the required rpms to turn the solenoid off, and the rpms returning to the shift point so fast that, although the solenoid technically was turned off, there was insufficient time for the shifter to re-cock itself for the next gear. The solution to this problem is the same as Step One.

PROBLEM: THE SOLENOID SHIFTS FROM 1ST DIRECTLY INTO 3RD

SOLUTION: First, verify that this is not a shifter problem. (Cable adjustment or improper shifter for the job). If the shifter is correct and the solenoid is shifting from 1st to 3rd, it is only doing it because it is told to. This would result from drive train slippage (see above), that allows the engine rpms to tell the RPM switch to turn on-off and on-off so fast, that you perceive it as a shift from 1st directly to 3rd. Solutions to this problem are the same as above. See Step #2.