



SHERWOOD®

# Maintenance & Repair Manual



A COMPLETE GUIDE TO RUBBER IMPELLER PUMP

## Why Service With Sherwood

The seawater pump is the heart of the marine engine, supplying a continuous water flow to maintain consistent engine temperatures. And, the #1 reason for Premature Engine Wear Is Overheating. To maintain engine performance, warranty and liability - - - insist upon the Original, Engine Tested & Engine Specified Sherwood.

### Sherwood History

Sherwood beginnings date back to 1903, when William Sherwood and his friend and business partner David Buick (of General Motors fame) operated a copper brass plumbing business. They parted ways as Buick became more interested in the automobile. Sherwood then developed the plumbing accessories and beer equipment business into a foundry and machine shop, where he was sought out by Ford, the Dodge brothers, and others for the expanding auto-driven industries in Detroit, Michigan.

In the 1920s, another entrepreneur named Chris Smith helped create the inboard-powered pleasure boat industry by combining automobile engines and boat hulls. His company, Chris-Craft, incorporated William Sherwood's expertise of plumbing and custom manufacturing, as they developed the first seawater pumps for marine inboard engines.

With the advent of World War II, Sherwood became a major supplier of marine engine coolant pumps for the U.S. Navy. On June 6, 1944, a Chris-Craft built personnel carrier with a Sherwood pump was the first allied landing craft to hit Normandy beaches. During this time, Sherwood also supplied pumps to marine engines of Buda, Caterpillar, Cummins, Gray, Hercules and Packard.

Following WWI, the pleasure boating industry grew. Sherwood evolved to accommodate the exacting cooling pump needs of this growing market. Sherwood kept pace with the new engines from Chrysler, Ford and GM by continuing, expanding and developing relationships with Chris-Craft, Chrysler Marine, Crusader, and OMC.

Over the years, Sherwood seawater pumps have developed a reputation of excellence in quality. Today, as part of Pentair, the Sherwood brand has taken the history of quality designs and manufacturing to become the seawater pump of choice for many of the most prestigious engine manufactures around the world.

## Table of Contents

	<b>Page</b>
Pumps .....	4
Engine Specified Pumps	
General Service Pumps	
Impellers .....	10
Performance	
Identification	
Kit Information	
Accessories .....	14
Strainers and Brackets	
Service Section .....	15
Pumps by Engine Manufacturer	
Other OEM and General Service Pumps	
Technical Guides.....	32
G Series	
R Series	
P Series	
17000 Series	
27000 Series	
18000 Series	
22000 and 30000 Series	
26000 Series	
29000 Series	
Preventative Maintenance and Inspection .....	58



## Engine Specified Pumps

**Model G20, G21**  
[See pages 22-23, 32-34]



**Model G30-2, G30-2B,  
G45-1**  
**Chris Craft 350 & 454**  
[See pages 16-17, 32-34]

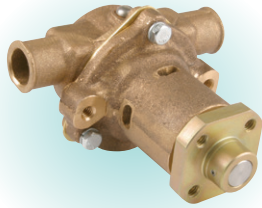

**Model R991**  
**Yamaha**  
[See pages 24-25]



**Model G9901**  
**OMC/Volvo 4.3-8.2**  
[See pages 22-25, 32-34]



**Model G9903**  
**Volvo/OMC 3.0-8.2**  
[See pages 22-25, 32-34]



**Model D55, D60, D65, D75**  
**Chrysler M225-M440**  
[See pages 18-19]



**Model N10360GX**  
**Chris Craft 283**  
[See pages 16-17]



**Model E35**  
[See pages 18-19, 35-36]



**Model G5, G7, G7B,  
G50**  
**Chrysler 318-340**  
[See pages 18-19, 32-34]



**Model P101, P1012,  
P1014**  
[See pages 28-29, 37-38]



**Model P105**  
[See pages 28-29]



The #1 Reason for Premature Engine Wear Is Overheating. To Maintain...



**Model P109, P110**  
 (See pages 28-29)



**Model P1017**  
 (See pages 28-29)

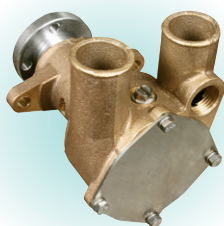

**Model G55-2**  
 (See pages 22-23, 32-34)



**Model G155**  
**Marine Corp/Star Power**  
 (See pages 22-23, 32-34)



**Model G151**  
**Marine Corp/Star Power**  
 (See pages 20-23, 32-34)



**Model G8001**  
 (See pages 28-29)

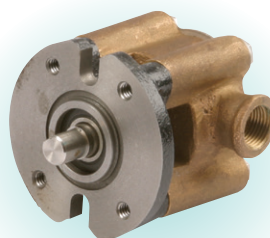

**Model G8002**  
 (See pages 28-29)



**Model G8005**  
 (See pages 28-29)



**Model R30G, R30G-1**  
 (See pages 24-25, 35-36)



**Model G701, G702**  
 (See pages 26-29)



**Model G906, G907**  
 (See pages 20-21)



...Engine Performance, Insist Upon Original Engine Specified Sherwood Products.

## Engine Specified Pumps

**Model G907P**  
(See pages 28-29)



**Model G910P**  
(See pages 28-29)



**Model G903, G908**  
(See pages 24-25)



**Model K75B, L10B**  
(See pages 20-21, 32-34)

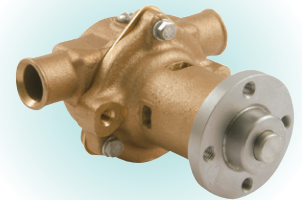

**Model G1006, G1008**  
(See pages 26-27)

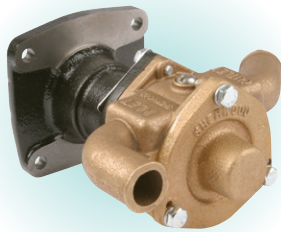

**Model G1010**  
(See pages 26-27)



**Model R50G, R10870G**  
(See pages 24-31, 35-36)

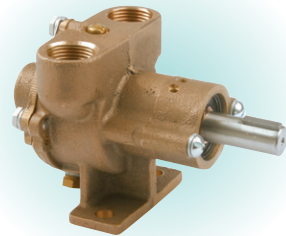

**Model H5**  
**Perkins**  
(See pages 22-23)



**Model G65**  
**Perkins**  
(See pages 22-23)



**Model M71**  
(See pages 28-29, 32-34)



**Model P1016**  
(See pages 28-29, 37-38)



The #1 Reason for Premature Engine Wear Is Overheating. To Maintain...

**Model RPBC  
Perkins**

(See pages 22-23)



**Model GC1**

(See pages 28-29, 32-34)

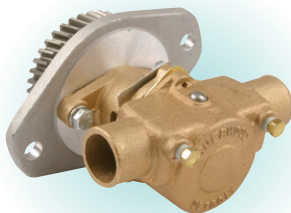

**Model GC4, GC5**

(See pages 28-29, 32-34)

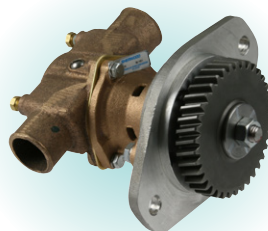

**Model P1505**

(See pages 28-29)



**Model P176**

(See pages 30-31, 39-41)



**Model P1710C, P1732C, P1710A,  
P1732A, P1710X, P1732X,  
P1710, P1732, P1726**

(See pages 28-31, 39-41)

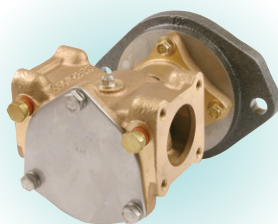

**Model P1719X, P1733X, P1719,  
P1733, P1711**

(See pages 28-31, 39-41)

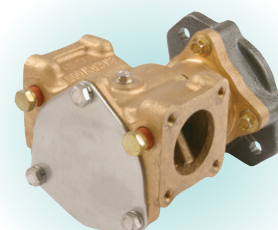

**Model P1716C, P1722C,  
P1716A, P1722A,  
P1716X, P1722X, P1716,  
P1722, P173**

(See pages 28-29, 39-41)



**Model P1727C, P1727A,  
P1727X, P1727**

(See pages 28-31, 39-41)



**Model P1730C, P1730A,  
P1730X, P1730, P1731**

(See pages 30-31, 39-41)



**Model P2708X, P2701,  
P2701X, P2702, P2704,  
P2705, P2706, P2708,  
P2709, P2710**

(See pages 30-31, 51-53)

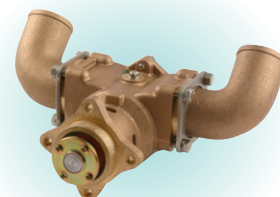

...Engine Performance, Insist Upon Original Engine Specified Sherwood Products.



**Model G2603X, G2603, G2601X,  
G2601, G2605**  
(See pages 26-27, 48-50)



**Model G2602**  
(See pages 26-27, 48-50)

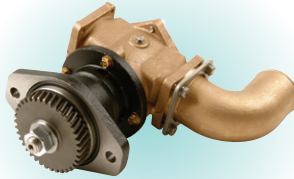

**Model G1801, G1805**  
(See pages 26-27, 42-44)

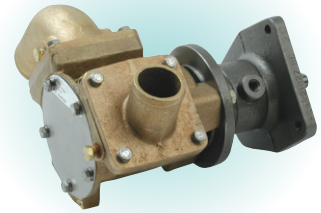

**Model G1806, G18061**  
(See pages 26-27, 42-44)

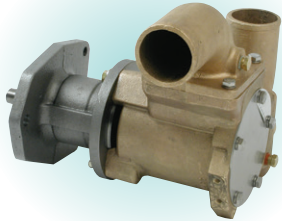

**Model G2904X, G2904,  
G18071X, G18071,  
G1807**  
(See pages 26-27, 42-44)

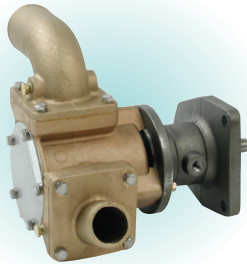

**Model G18081,  
G1808**  
(See pages 26-27, 42-44)



**Model G2902X, G2902,  
G18082X, G18082**  
(See pages 26-27, 42-44)



**Model G2903X, G2903, G1810X,  
G1814X, G1810, G1811, G1814**  
(See pages 26-27, 42-44)



**Model G22011, G2201**  
(See pages 26-27, 45-47)

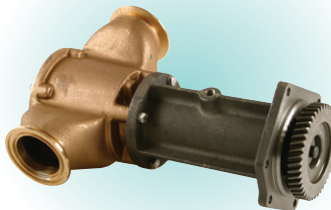

**Model G3001X, G3001,  
G22012X, G22012**  
(See pages 26-27, 45-47)

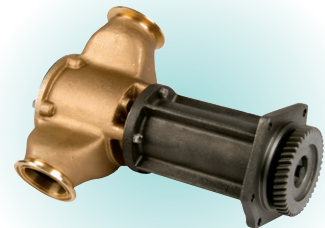

# General Service Pumps

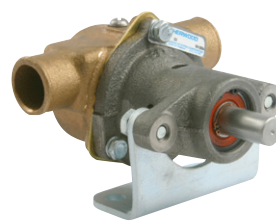

Horizontal Porting G1 & G3

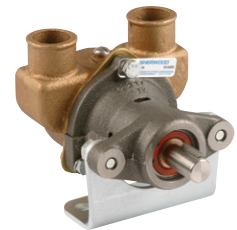

Vertical Porting G2, G4, & G11

## G Series

- Mechanical Seal
- Bronze Housing
- Stainless Steel Shaft
- Sealed Ball Bearing
- Excellent for Engine Cooling, Either as Replacement for Obsolete Pump or New Installation

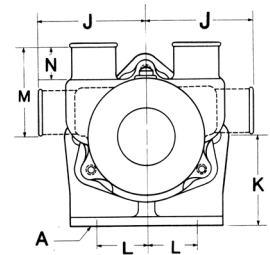
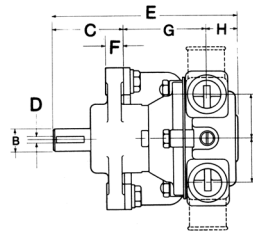
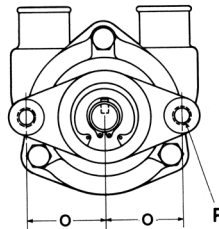

Model No.	Impeller	Port Size	Dimensions (Inches)															
			A	B	C	D	E	F	G	H	I	J	K	L	M	N	O	P
G1	09959	1" Hose	13/32	5/8	2-1/64	3/16	5-1/4	1/2	2-25/64	27/32	1-1/4	2-5/8	2-1/8	1-3/8	-	7/8	1-5/8	3/8
G2	09959	1" Hose	13/32	5/8	2-1/64	3/16	5-1/4	1/2	2-25/64	27/32	1-1/4	-	2-1/8	1-3/8	2-1/4	7/8	1-5/8	3/8
G3	10615	1-1/4" Hose	13/32	5/8	2-1/64	3/16	5-5/8	1/2	2-37/64	1-1/32	1-1/2	2-5/8	2-1/8	1-3/8	-	7/8	1-5/8	3/8
G4	10615	1-1/4" Hose	13/32	5/8	2-1/64	3/16	5-5/8	1/2	2-37/64	1-1/32	1-1/2	-	2-1/8	1-3/8	2-5/16	7/8	1-5/8	3/8
G11	09000	1/2" NPT	13/32	5/8	2-1/64	3/16	5-1/4	1/2	2-25/64	27/32	1-1/4	-	2-1/8	1-3/8	2-1/4	7/8	1-5/8	3/8

• See Impeller Flow Curves on Page 10 for Performance.

## R Series

- Heavy Duty Design for Pulley Drive or Long Couple
- Mechanical Seal for Extended Seal Life
- Rear Support Bushing for Load Absorption
- Ball Bearing Supported Drive Shaft
- Corrosion Resistant Bronze Constructed
- Neoprene Impeller and Buna Seal - Standard
- Stainless Steel Shaft

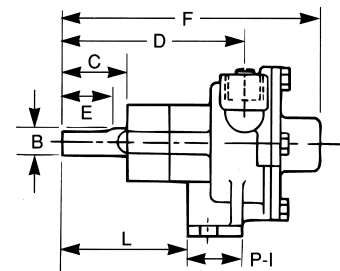
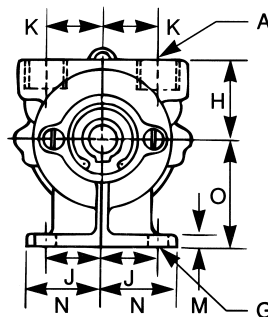
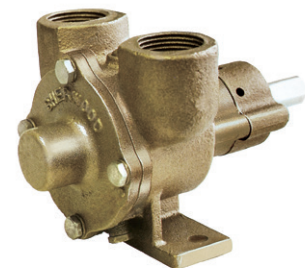

Model No.	Impeller	Port Size	Dimensions (Inches)														
			B	C	D	E	F	G	H	I	J	K	L	M	N	O	P
R30G	10077	1/2" NPT	.50	1.50	3.56	1.0	5.28	.34	1.47	.75	1.06	1.12	3.09	.25	1.44	1.38	.44
R50G	09959	3/4" NPT	.63	1.50	4.06	1.0	5.28	.41	1.63	.75	1.12	1.25	3.34	.25	1.50	2.12	.50
R102	10615	1" NPT	.63	1.50	4.53	1.0	6.66	.41	2.12	.88	1.38	1.50	3.97	.25	1.81	2.12	.56

• Recommended Horsepower: R30G - 1/2, R50G - 3/4, R102 - 2. See Impeller Flow Curves on page 10 for Performance.

# Impeller Performance

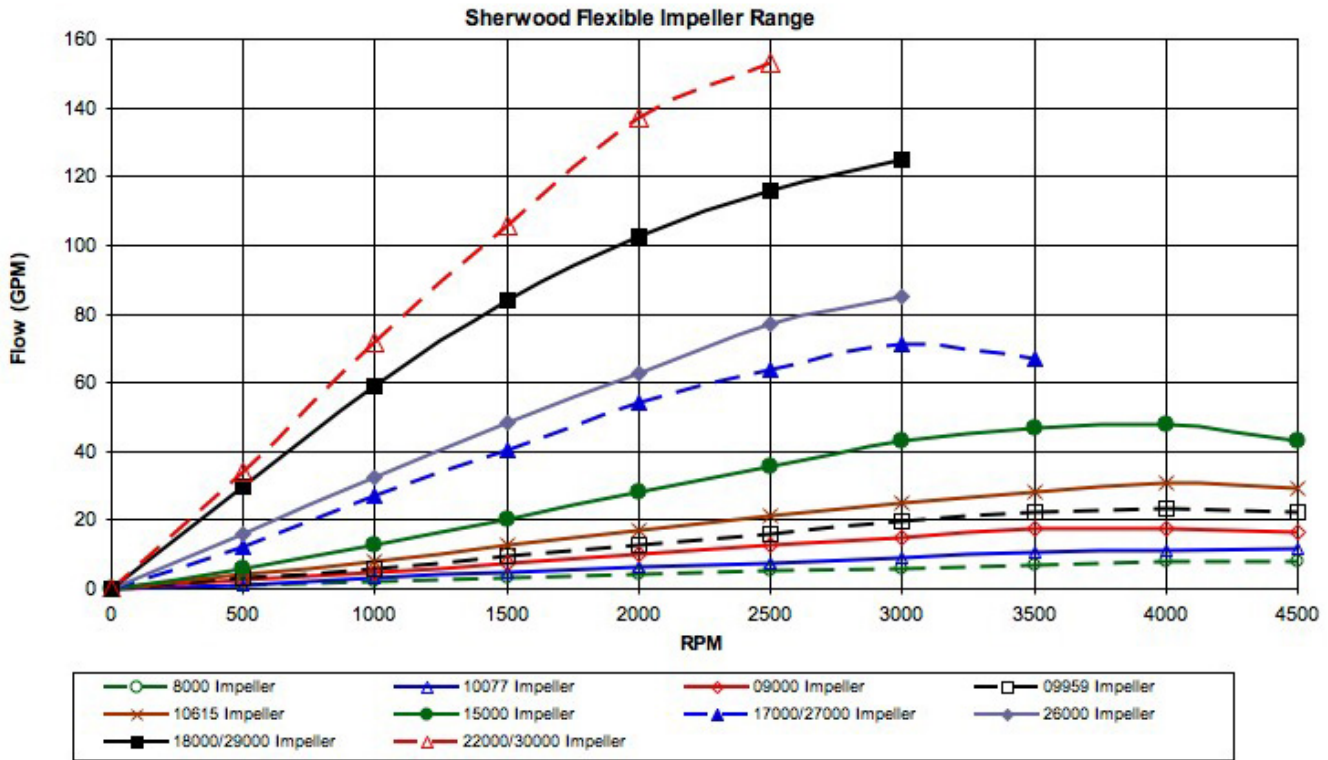

## Genuine Sherwood Impellers & Impeller Kits

### Patented Impeller Puller

17000A, 18000, 22000, 26000, 27000, 29000, 30000 impellers contain a patented threaded insert design. Patent No. 6,116,855.

### 25105 & 23631 Puller used for:

17000A, 18000, 22000, 26000, 29000, 30000

### 25106 & 24412 Puller used for:

27000



### Impeller Kits Include:

All Gaskets, O-rings, new Technical Service Guide and Engine Specified Impeller for up to 50 Sherwood pumps.

### Impeller Kits Available:

08000K	18000K
09000K	22000K
10077K	26000K
09959K	27000K
10615K	29000K
15000K	30000K
17000K	





# Impeller Removal and Installation

## Threaded Impellers

(17000A\*, 18000, 22000, 26000, 27000, 29000, and 30000). Patent No. 6,116,855.

\*17000A standard impeller in 17000K is threaded/thru-key design.

### Removal

- Remove the cover.
- Insert the Sherwood puller into the threaded insert.
- Screw the puller against the shaft, lifting the impeller out of the housing or until loose.
- Twist and pull the impeller out of the pump.

### Installation

- Apply a non-petroleum based lubricant to impeller (i.e. silicone or soapy water).
- Install the impeller with a twisting motion onto the shaft.
- Option: Use puller tool to push impeller into pump by loosening and lowering nut until tightens against impeller insert, then turning for installation.
- Then use a small amount of non-petroleum based lubricant to help hold the o-ring in place while replacing the cover.
- For the 17000K\*\*, align key and keyway by rotating the impeller.

\*\***Caution:** Replace impeller key and place the rubber cap over the key opening to prevent possible damage to the cover.

## Thru-Key Design Impellers

(8000K, 10077K, 09000K, 09959K, 10615K, 15000K, 17000K\*)

\*17000A standard impeller in 17000K is threaded/thru-key design.

### Removal

- Remove the cover.
- Twist and pull the impeller out of the pump.

### Installation

- Apply a non-petroleum based lubricant to impeller (i.e. silicone or soapy water).
- For non-rock key version pumps, install the key into the shaft prior to installing the impeller.
- Install the impeller with a twisting motion onto the shaft.
- After the impeller is all the way on the shaft and into the housing, rotate the impeller to align the keyway of the shaft to the key slot on the shaft.
- Slide the impeller key into the keyway and if applicable place the rubber cap over the key opening.
- Then use a small amount of non-petroleum based lubricant to help hold the o-ring in place while replacing the cover.



Threaded Impellers



17000A Thru-Key Design



Thru-Key Impellers

To maintain engine performance, insist upon genuine Sherwood impellers.

Keep it cool with the original!

# Impeller Specifications

**10615K** Width: 1-5/8" [41mm]  
Diameter: 2-9/16" [65mm]

**15000K** Width: 2" [51mm]  
Diameter: 2-9/16" [65mm]

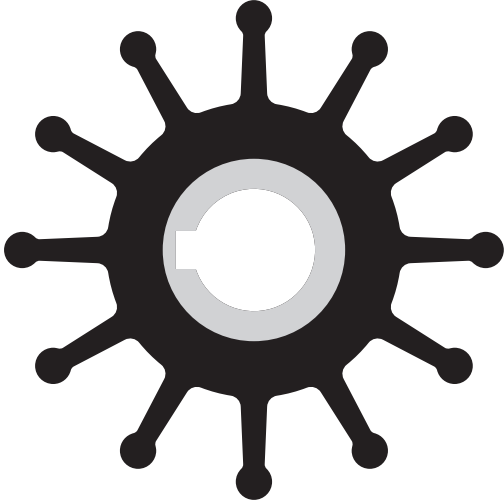

**09959K** Width: 1-1/4" [32mm]  
Diameter: 2-7/16" [62.5mm]

**09000K** Width: 7/8" [22mm]  
Diameter: 2-7/16" [62.5mm]

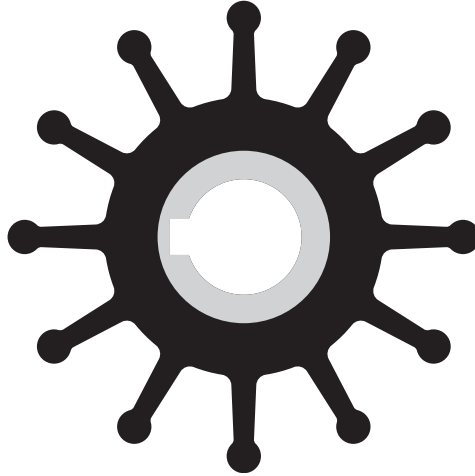

**10077K** Width: 25/32" [20mm]  
Diameter: 2-1/4" [57mm]

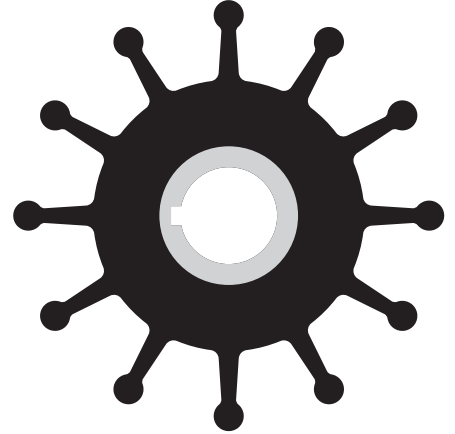

**17000K** Width: 2-7/8" [73mm]  
Diameter: 3-5/16" [84mm]  
Threaded/Thru-key  
Insert

**08000K** Width: 3/4" [19mm]  
Diameter: 1-9/16" [40mm]

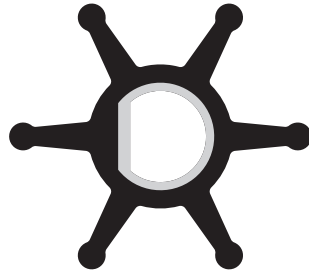

**29000K** Width: 4" [102mm]  
Diameter: 3-3/4" [95mm]  
45° 10 Tooth Spline

**18000K** Width: 4" [102mm]  
Diameter: 3-3/4" [95mm]  
Note: 18000S is an 18000 impeller with a stainless steel insert.  
30° 14 Tooth Spline

**26000K** Width: 3-1/8" [80mm]  
Diameter: 3-3/4" [95mm]  
45° 10 Tooth Spline

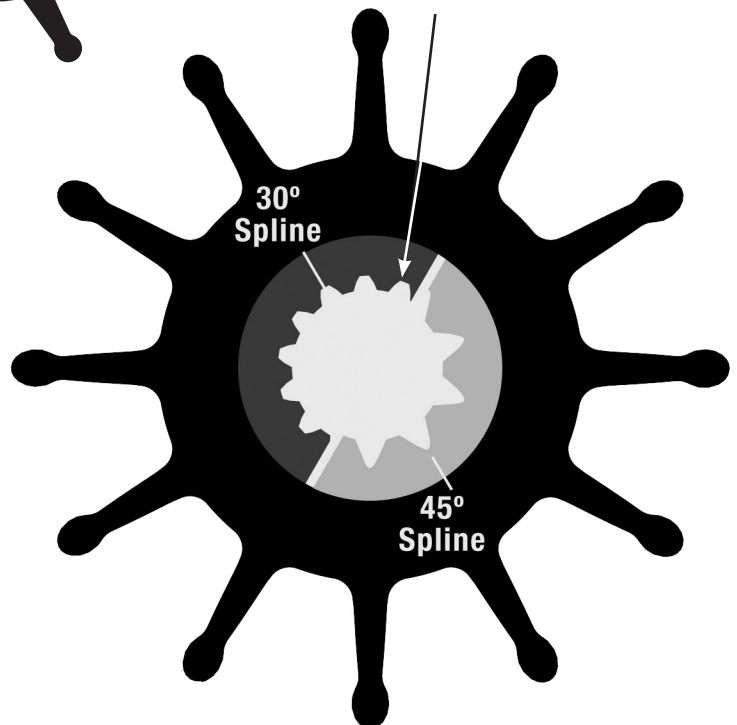
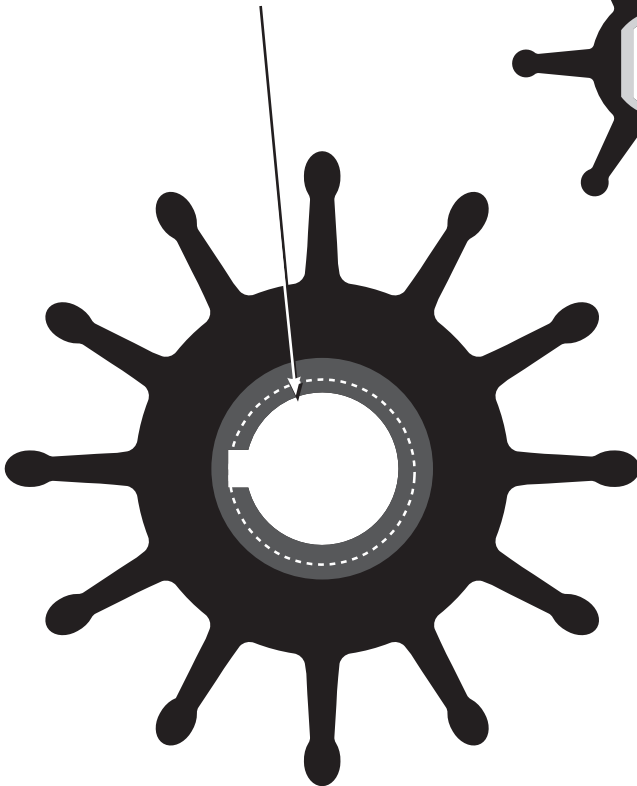

**27000K** Width: 2-7/8" (73mm)  
 Diameter: 3-5/16" (84mm)  
 Splined Impeller

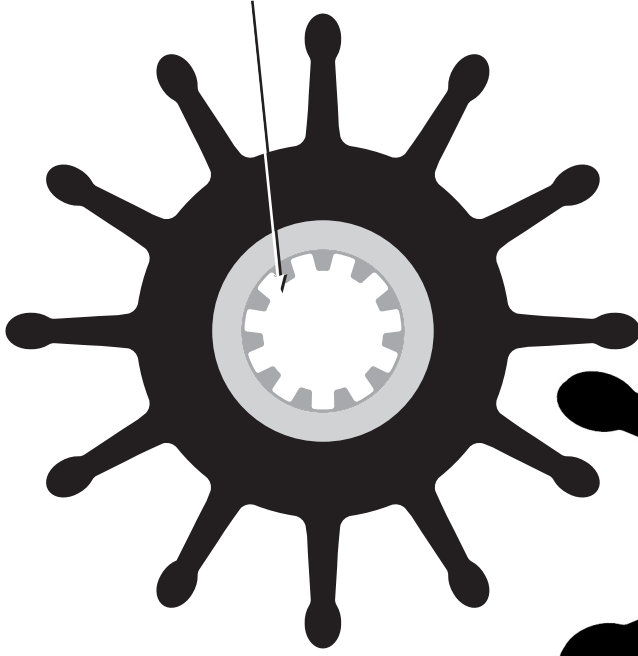

**30000K** Width: 4-5/16" (110mm)  
 Diameter: 4-1/2" (114mm)  
 45° 10 Tooth Spline

**22000K** Width: 4-5/16" (110mm)  
 Diameter: 4-1/2" (114mm)  
 30° 14 Tooth Spline

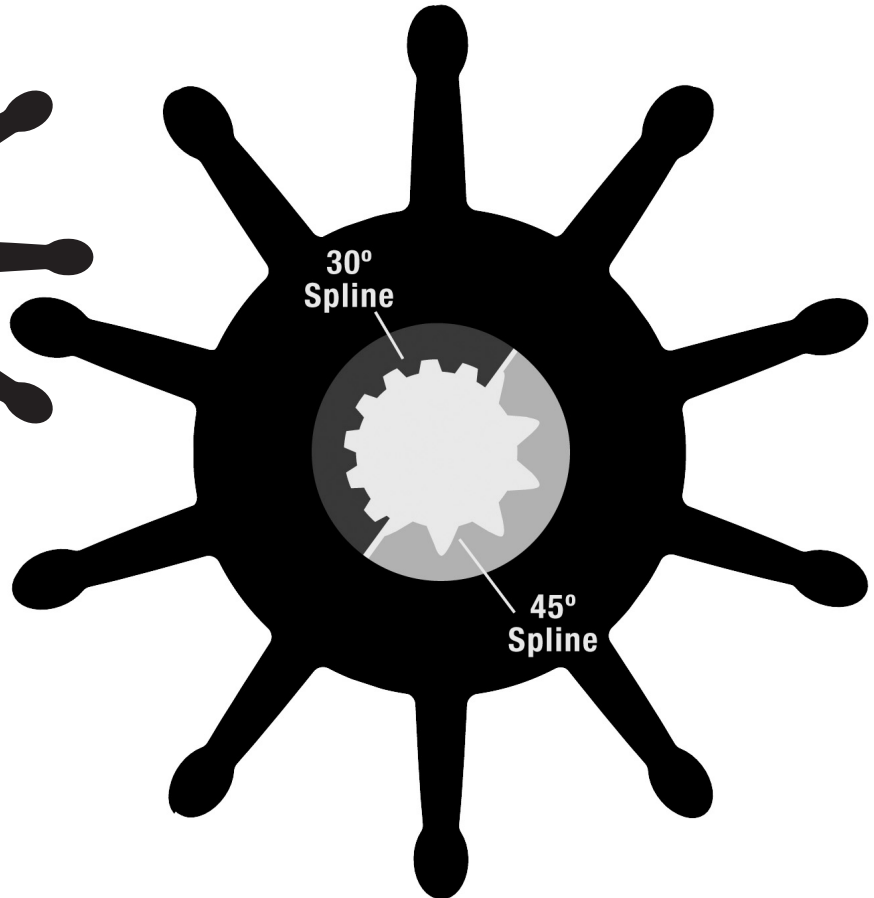

**Additional Impellers**

Part #	Diameter	Width	Shaft	Keyway	Number of
<i>Vanes</i>					
10187	2-19/32" (66mm)	1-31/32" (50mm)	5/8"	3/16"	

**Vane Impellers**

Vane Assembly Number	Vane Description	Number of Vanes Per Set	Vane Pumps
09731	1-1/4"L x 13/16"W x 1/8"H	7 (08888)	K9615G, K9635G, K9740G
09745	1-1/4"L x 13/16"W x 1/8"H	14 (08888)	K9529G, K9820G, L9841G, L9850G, L9870G, L9875G
09924	25/32"L x 11/16"W x 1/8"H	16 (09915)	L9910G, M10080G, N10160G

Impeller vanes were used for raw water pump applications prior to the design of the flexible rubber impeller. Vanes are packaged in sets and must be ordered by assembly number.



# Seawater Strainer and Bracket



- Full-Flow Filtering with Ultra-Low Pressure Differential
- Easy In-Line Cleaning
- Durable Non-Corrosive Construction
- Quick Clear Bowl Examination
- Lightweight with Optional Mounting Bracket
- Stainless Steel Screens

### Strainer Description

Strainer Number	Port Size (NPT)	Screen Mesh	Bracket No.
15935	1/2"	20 Mesh	N/A
18004	1/2"	50 Mesh	N/A
18001	3/4"	20 Mesh	14240
18005	1"	20 Mesh	14239
18016	1-1/4"	20 Mesh	14238
18029	1-1/2"	20 Mesh	21930

### Strainer Components

Strainer Number	Screen No.	O-ring No.	Bowl No.
15935	11810	11805	14379
18004	11811	11805	14379
18001	11810	11805	14379
18005	11807	11803	14380
18016	14214	11803	14380
18029	16126	11803	14380

### All Dimensions (In Inches):

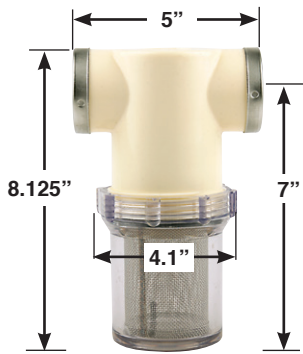

1-1/2" Strainer  
18029

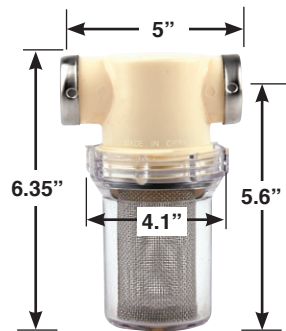

1-1/4" Strainer  
18016

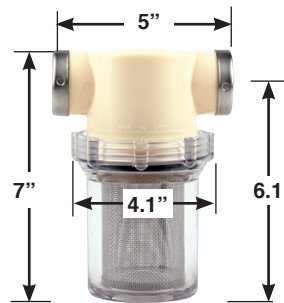

1" Strainer  
18005

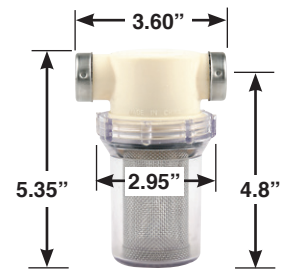

1/2" & 3/4" Strainer  
18001/18004/15935

### Screen Identification

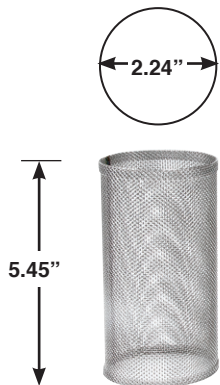

16126

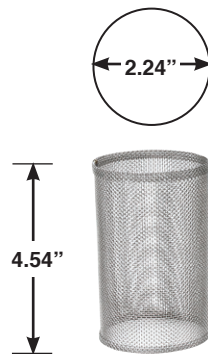

14214

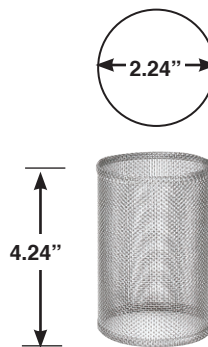

11807

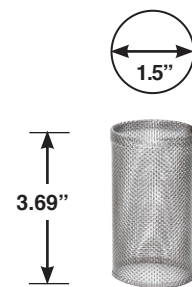

11810 - 20 mesh  
11811 - 50 mesh

# Pump Service Parts

## Major Pump and Parts Service Section

The following parts list is made available for the identification of major components of raw water pumps currently active in marine engine applications. Although the pump may no longer be a unit in production, it may be a serviceable pump. This is intended to assist the distributors and their dealers with identification and ordering of parts.

Engine Manufacturer		Sherwood	Pump	Replacement	Ports		Impeller	Minor	Major	Seal &
		Number	Avail	Pump			Kit	Repair	Repair	Seat/
								Kit	Kit	Lip Seal
Gov Life Boat	11658	B11	O	*	1/2" NPT	1/2" NPT	*		13369	11367
Gov Life Boat	11353	R10870G-01	S	R10870G	3/4" NPT	3/4" NPT	09959K	10997	12937	10927
Gov Life Boat	24143	H70	O	*	7/8"	7/8"	10077K	*	13366	11628C
Model 283	16.80-10003	N10360GX	S		1/2" NPT	1/2" NPT	(2) 10077K	10244	12301	10546
Model 307-327Q	16.80-28342	D10C	O	*	-	-	10635			10577
Model 307-327Q	16.80-28341	D15CC	O	*	-	-	10557			10577
M383X, M413E, M440X	E-7592-M	P10550G	O	D55	1 1/4"	1 1/4"	09959K & 10615K		*	10545
		P1730A	S		W/O Port Elbow	W/O Port Elbow	17000K			23799/24250

SERVICE

D10C Centrifugal recirculating pump clockwise rotation from pulley end  
 D15CC Centrifugal recirculating pump counterclockwise rotation from pulley end

- O Obsolete pump, no longer in production
- P Proprietary pump, must purchase through engine manufacturer or their distributor
- S Sherwood pump, purchase direct from Sherwood distributor

R10870G Pump shown in this column is a direct replacement  
 \* Asterisk indicates no direct replacement available

NPT indicates threaded port (national pipe thread)      1/2" NPT      1/2" NPT  
 Dimension indicates outside diameter of port      1 1/4"      1 1/4"  
 Signifies that the pump is sold without any port elbows      W/O Port Elbow      W/O Port Elbow

For gear pumps, first item drive gear, second item is the idler      05237/05725  
 Rubber Impeller (2) per pump      (2) 10077K  
 Pump uses both a 09959 and 10615 impeller      09959K & 10615K

Complete Seal and Seat Assembly      10545  
 Mechanical Seal followed by the Lip Seal      23799/24250

**GENERAL PARTS INFORMATION**  
 \*Asterisk indicates parts are obsolete.  
 Blank space indicates part not used in pump design.

**Note:** All Sherwood part numbers now contain the suffix "-SHW."  
**Example:** "17000K is now "17000K-SHW."

ENGINE MANUFACTURER		SHERWOOD NUMBER	PUMP AVAIL	PREPLACEMENT PUMP	PORTS		IMPELLER KIT	MINOR REPAIR KIT	MAJOR REPAIR KIT	SEAL & SEAT/ LIP SEAL	BEARING ASSEMBLY
ENGINE MODEL	ENGINE PART NO.				INLET	OUTLET					
CHRIS CRAFT											
Model A		G8456	O	*						*	
Model A		A16	O	*	1"	1"	09959K			10927	4257
Model B		D7704	O	*	3/8"	3/8"				*	*
Model B		D7730	O	*	3/8"	3/8"				*	*
Model B		G8450	O	*	3/8"	3/8"				*	4306
Model B		K9750G	O	*	3/8"	3/8"				10546	4306
Model B		M10261G	O	*	3/8" NPT	3/8" NPT	10077K			10546	4306
Model K		D7669	O	*	1/2"	1/2"				*	*
Model K		D7729	O	*	1/2"	1/2"				*	*
Model K		G8451	O	*	1/2"	1/2"				10522C	4306
Model K		K9710G	O	*	1/2"	1/2"				10546	4306
Model K	16.80-10007	M10262G	O	*	1/2" NPT	1/2" NPT	10314			10546	4306
Model M		D7710	O	*	3/4"	3/4"				*	*
Model M		D7731	O	*	3/4"	3/4"				*	*
Model M		G8452	O	*	3/4"	3/4"				*	4306
Model M		K9635G	O	*	3/4"	3/4"				10546	4306
Model M	16.80-10008	M10263G	O	*	3/4" NPT	3/4" NPT	09959K	09959K	12246	10545	4306
Model W		G8453	O	*	1"	1"				*	*
Model W		K9740	O	*	1"	1"				10545	4257
Model W	16.80-10009	M10264G	O	*	1" NPT	1" NPT	09959K	09959K		10545	4257
Model 283		L9980G	O		N10360GX	1/2"	1/2"			10546	4306
Model 283		L9910G	O		N10360GX	1/2"	1/2"	09924		10546	4306
Model 283		N10160G	O		N10360GX	1/2"	1/2"	09924		10546	*
Model 283		M10095G	O		N10360GX	1/2"	1/2"	(2) 10077K	10244	10546	4306
Model 283	16.80-10003	N10360GX	S			1/2" NPT	1/2" NPT	(2) 10077K	10244	12301	10546
Model 283M		L9980G	O		N10360GX	1/2"	1/2"			10546	4306
Model 283F		Q10780G	O		S11095G	1" NPT	1" NPT			10545	19988
10769	Model 283F	16.80-27555	Q10825CC	O	*	-	-	*		12249	10577
	Model 283F	16.80-27554	Q10830C	O	*	-	-	10635		12249	10577
	Model 307-327Q	16.80-18340	D05	O		1"	1"	10615K	11430C	10927	(2) 4257
	Model 307-327Q	16.80-28342	D10C	O	*	-	-	10635		10577	14055
	Model 307-327Q	16.80-28341	D15CC	O	*	-	-	*		10577	14055
10769	Model 327F		Q10780G	O		S11095G	1" NPT	1" NPT		10545	19988
10769	Model 327F		S11095G	O		1"	1"	10615K		10545	19988
10769	Model 327F		Q10825CC	O	*	-	-	*		12249	10577
	Model 327F		Q10830C	O	*	-	-	10635		12249	10577



# Pumps by Engine Manufacturer

SHAFT	CAM	GASKET / O-RING	BUSHING	BODY	CAM SCREW	COVER	HOUSING	WEAR PLATE	KEY	PIN	SLINGER	RETAINING RING	PULLEY / GEAR / HUB / ADAPTER
*				*		*	*		17658	*	7070		
*	10072	10103	6333	*			*		4432	1311	1410-0056	(2) 4258/4259 (1)	
*		(4) 5248		*	*	*	*		17658	*	7070		
*		(4) 5248	*	*	*	*	*		17658	*			7070
*		(4) 5248	*	*	*	*	*	*	17658	*	7070		
*	*	9484	2075	*		*		*		*			7070
*	10285	10286	2075	*	12686	10279			10093	*	7070		4304
*		(4) 5248	*	*	*	*	*	*	17658	*			7070
*		(4) 5248	*	*		*	*	*	17658	*			7070
*		(4) 5248	*	*		*	*	*	17658	*			7070
*	*	9484	2075	*		*				*	7070		
*	*	10286	2075	*	10195	10279		10079	17658	*	7070		4304
*		(4) 5248	*	*	*	*	*	*	17658	*			7070
*		(4) 5248	*	*	*	*	*	*	17658	*	7070		
*		(4) 5248	*	*	*	*	*	*	17658	*	7070		
*	*	9484	2075	*		*		*		*	7070		
*	10072	10103	6333	*	9919	10094			4432	*	14990	4258	
*		*	*	*	*	*		*	17658	*	7070		
*	*	9484	6333	*		*		*		528	*		
*	10072	10103	6333	*	9919	10094		*	4432	528	14990	4258	
*		*	*	*	*	*	*	*	17658	528	7070		4304
*	*	9917/9918	2075	9909	9919	9907	*	*		528			
*	*	9917/9918	2075	9909	9919	9907	*	*		528			
10078	10134	9917/9918	2075	9909	9919	9907	*	10079	10093	528			4304
10078	10134	9917/9918	2075	9909	9919	9907	10416C	10079	10093	528			4304
*		*	2075/*	*	12686	*	*	*	17658	528	7070		4304
		*	6333/*	*	*		*	*	4432	9420			4258
		10575				*	*				1410-0056		10574
		10575				*	*				1410-0056		10574
11429	10944	10931	6333	11428	10515C		*		4432	1311		(2) 4258/4259 (1)	
		15945				*	*				1410-0056		10574
		15945				*	*				1410-0056		10574
*		*	6333/*	*	*		*	*	4432	9420			(2) 4258
14212	10944	10971	6333		10515C	10182	*		4432	9420			(2) 4258/8781 (1)
		10575					*				1410-0056		10574
		10575					*				1410-0056		10574

ENGINE MANUFACTURER		SHERWOOD NUMBER	PUMP AVAIL	PREPLACEMENT PUMP	PORTS		IMPELLER KIT	MINOR REPAIR KIT	MAJOR REPAIR KIT	SEAL & SEAT/ LIP SEAL	BEARING ASSEMBLY
ENGINE MODEL	ENGINE PART NO.				INLET	OUTLET					
Model 427	16.80-10010	S11095G	O		1"	1"	10615K	11102	12308	10545	19988
Model 427	16.80-07808	S11110C	O	*	-	-	10635			10577	14055
Model 427	16.80-11007	S11115CC	O	*	-	-	*			10577	14055
Model 430		N10450	O	N10360GX	-	-				10545	4257
Model 430		M10080G	O	N10360GX	-	-	09924			10546	4306
Model 430		N10200G	O	N10360GX	-	-	(2)10077			10546	4306
Model 430		N10370G	O	N10360GX	-	-	(2)10077			10546	4306
Model 430	16.80-10003	N10360GX	S		1/2" NPT	1/2" NPT	(2)10077	10244	12301	10546	4306
Model 431		P10670	O	N10360GX	-	-				10545	4257
Model 431		N10490CC	O	*	-	-	*			10577	14055
Model 431		N10580C	O	*	-	-	10635			10577	14055
Model 350	16.80-18344	G15	O		1"	1"	09959K	23979	12665	12859	(2) 23448
Model 350	16.80-18346	G30-2	O	G30-2B	1"	1"	09959K	23979	12665	12859	(2) 23448
Model 350	16.80-18346	G30-2B	S		1"	1"	09959K	23979	12665	12859	(2) 23448
Model 454	16.80-18347	G45-1	S		1 1/4"	1 1/4"	10615K	23976	23977	12859	(2) 23448
<b>CHRYSLER MARINE</b>											
318 and 360	4142878	G7	O	G7B	1 1/4"	1 1/4"	10615K	23976	23977	12859	(2) 23448
318 and 360	4142878	G7B	S		1 1/4"	1 1/4"	10615K	23976	23977	12859	(2) 23448
M80 (CW)	E5913-M	P10560G	O	*	-	-	(2)09959K			10545	*
M80 (CCW)	E5839-M	P10710G	O	*	-	-	(2)09959K			10545	*
Slant 6	E-7783-M	P10610G	O	*	-	-	09959K	09959K	12252	10545	4257
Slant 6	2659553	A03	O	*	-	-	09959K		*	10545	4257
M225X	E-8542-M	Q10855G	O	D60	1"	1"	(2) 09959K	09959K		10545	19988
M225X	2847632	D75	O	D60	1"	1"	(2) 09959K	10656		10927	4257
M273X, LM318X	E-9327-M	R10935G	O	D60	1"	1"	(2) 09959K	09959K	12814	10545	19988
M273X, LM318X	2847630	D60	S		1"	1"	(2) 09959K	10656	12300	10927	4257
M273X, LM318X	E-7584-M	N10390G	O	D60	1"	1"	(2) 09959K	09959K	12814	10545	19988
M273X, LM318X	2847631	D65	O	D60	1"	1"	(2) 09959K	10656	12300	10927	4257
M383X, M413E, M440X	E-7592-M	P10550G	O	D55	1 1/4"	1 1/4"	09959K & 10615K			10545	19988
M383X, M413E, M440X	2847629	D55	S		1 1/4"	1"	09959K & 10615K			10927	4257
LM318-X, LM340-X	2846428	C-03	O	G7B	-	-	10615K	10999	11068	10927	4257
LM318-X, LM340-X	3675763	G5	O	G7B	1 1/4"	1 1/4"	10615K	23976	23977	12859	(2) 23448
LM318-X, LM340-X	3745511	G5-1	O	G7B	1 1/4"	1 1/4"	10615K	23976	23977	12859	(2) 23448
LM318-X, LM340-X	3619030	F10	O	G50	1 1/4"	1 1/4"	10615K	10999	11068	10927	4257
LM318-X, LM340-X	3619212	G50	O		1 1/4"	1 1/4"	10615K	23976	23977	12859	(2) 23448
<b>COMMANDER</b>											
302 and 351	CM1-10-610	J70	O		1"	1"	09959K	23979	12665	12859	(2) 23448
302 and 351	C2-10-610	L80	O		1 1/4"	1 1/4"	10615K	23976	23977	12859	(2) 23448
<b>CRUSADER (DEARBORN )</b>											
Model 220,270,300,350	97179	E35	S		1" NPT	1" NPT	10615K	10999	11068	10927	4257
Chevy RH Rotation		L9820G	O	*	-	-	09745			10545	4257
Chevy RH Rotation		L9870G	O	*	-	-	09745			10545	4257
Chevy RH Rotation		M10270G	O	*	1" NPT	1 1/4"	(2)09959K			10545	4257
Chevy LH Rotation		L9841G	O	*	-	-	09745			10545	4257
Chevy LH Rotation		L9875G	O	*	-	-	09745			10545	4257
Chevy LH Rotation		M10280G	O	*	1" NPT	1 1/4"	(2)09959K			10545	4257
Chevy LH Rotation		Q10755G	O	*	-	-	09959K			10545	4257
Chevy LH Rotation	1000269	Q10775G	O	*	-	-	10187		*	10758	4257
Chevy LH Rotation	1001984	S11085G	O	*	1 1/2"	1"	10187		*	10758	4257

SHAFT	CAM	GASKET / O-RING	BUSHING	BODY	CAM SCREW	COVER	HOUSING	WEAR PLATE	KEY	PIN	SLINGER	RETAINING RING	PULLEY / GEAR / HUB / ADAPTER
14212	10944	10971	6333		10515C	10182	*		4432	9420		(2) 4258/8781 (1)	10769
							*				1410-0056	10574	
							*				1410-0056	10574	
*		*	6333/*	*	*	*	*	*	17658	528	*	4258	
*	10134	9917	2075	9909	9919	*	*	*		528			*
10078	10134	9917	2075	9909	9919	*	*	*	10093	528		4304	
10078	10134	9917	2075	9909	9919	*	*	*	10093	528		4304	
10078	10134	9917/9918	2075	9909	9919	9907	10416C	10079	10093	528		4304	
*		*	6333/*	*	*	*	*	*	17658	528		4258	
		10575				*	*				1410-0056	*	*
		10575				*	*				1410-0056	*	*
12233	15883	12231/12855		14160	10515C		12303	12856	4432/12622			12305/(2), 4258/4259 (2)	12323
12612	15883	12231/12855		12328	10515C		12303	12856	4432	12791		(3) 4258/4259 (2)	12615
12612	15883	12231/12855		19784	10515C		12303	12856	4432	12791		(3) 4258/4259 (2)	12615
12612	10944	12231/12855		12328	10515C		12228	12856	4432	12791		(3) 4258/4259 (2)	12615
13363	10929	12231/12855		12227	10515C		12952	12856	4432			(3) 4258/4259 (2)	15055
13363	10929	12231/12855		19789	10515C		12952	12856	4432			(3) 4258/4259 (2)	15055
*	(2) 10072	(2) 10103	6333	*	(2) 9919	10094	*	*	4432				
*	(2) 10072	(2) 10103	6333	*	(2) 9919	10094	*	*	4432				*
	10072	10103	6333	*	9919	10094	*		4432/*	1311		4258/4259	
*	10072	*	6333	*	9919				4432	1311	*	4258/4259	*
10501C	(2) 15883	(2) 10609	6333		(2) 10515C	*	*	10625	(2) 4432	(2) 413	*	4258/8781	*
11459	(2) 15883	(2) 10609	6333	11454	(2) 10515C	10611C		10625	(2) 4432/11515	(2) 413		(3) 4258/4259 (1)	12326
10501C	(2) 15883	(2) 10609	6333	*	(2) 10515C	10913	*	10625	(2) 4432	(2) 413	*	4258	*
11459	(2) 15883	(2) 10609	6333	11454	(2) 10515C	10913	*	10625	(2) 4432/11515	(2) 413		(3) 4258/4259 (1)	12326
10501C	(2) 15883	(2) 10609	6333	*	(2) 10515C	*	*	10625	(2) 4432/*	(2) 413	*	4258/8781	*
11459	(2) 15883	(2) 10609	6333	11454	(2) 10515C	10611C		10625	(2) 4432/11515	(2) 413		(3) 4258/4259 (1)	12326
*	15883/10944	10609/10612	6333	*	(2) 10515C	*		10625	(2) 4432	(2) 413	*	4258/8781	*
11460	15883/10944	10609/10612	6333	11455	(2) 10515C	10611C		10625	(2) 4432/11515	(2) 413		(3) 4258/4259 (1)	12326
*	10944	10612	6333	*	10515C	*			4432	1311		(2) 4258/4259	*
12233	10944	12231/12855		12227	10515C		12228	12856	4432	11541		(2) 4258/4259 (2)	12326
12233	10929	12231/12855		12227	10515C		12952	12856	4432	11541		(2) 4258/4259 (2)	*
*	10944	10612	6333	*	10515C	*			4432	1311		(3) 4258/4259	*
12233	10944	12231/12855		12227	10515C		12228	12856	4432	11541		(3) 4258/4259, (2) 12305	12323
13274	15883	12231/12855		12328	10515C		12303	12856	4432/12622			(3) 4258/4259 (2)	13429
13274	10944	12231/12855		12328	10515C		12228	12856	4432/12622			(3) 4258/4259 (2)	13429
11744	10944	10931	6333	11245	10515C	10182			4432	(2) 1311		(2) 4258/4259 (1)	97176
*	*	9484	6333	*	*	*	*	*		413		4258/4259	*
*	*	9484	6333	*	*	*	*	*		413		4258/4259	*
*	*	(2) 10103	6333	*	9919	10094	*	*	(2) 4432	413		(2) 4258/4259	*
*	*	9484	6333	*	*	*	*	*		413		4258/5328	*
*	*	9484	6333	*	*	*	*	*		413		4258/5328	*
*	*	(2) 10103	6333	*	9919	10094	*	*	(2) 4432	413		(2) 4258/4259	*
*	15883	*	6333	*	10515C	*	*		4432	1311		(2) 4258/4259	*
10748	*	10752	6333	*	10515C	*	*		4432	1311		(2) 4258/4259	*
10748	*	10752	6333	*	10515C	*	*		4432	1311		(2) 4258/4259	*

ENGINE MANUFACTURER		SHERWOOD NUMBER	PUMP AVAIL	PREPLACEMENT PUMP	PORTS		IMPELLER KIT	MINOR REPAIR KIT	MAJOR REPAIR KIT	SEAL & SEAT/ LIP SEAL	BEARING ASSEMBLY
ENGINE MODEL	ENGINE PART NO.				INLET	OUTLET					
Chevy RH Rotation		Q10765G	O	*	-	-	09959K			10545	4257
Chevy RH Rotation	1000270	Q10785G	O	*	-	-	10187		*	10758	4257
Chevy RH Rotation	1001985	S11090G	O	*	1 1/2"	1"	10187		*	10758	4257
Interceptor		M10210G	O	P10700G	-	-	09959K	09959K	12252	10545	4257
Interceptor		N10410G	O	P10700G	-	-	09959K	09959K	12252	10545	4257
Interceptor		P10700G	O		3/4" NPT	3/4" NPT	09959K	09959K	12252	10545	4257
Interceptor		F15	O	R50G	3/4" NPT	3/4" NPT	09959K			10927	4257
Model 220,270,300,350		S11040G	O	E35	1" NPT	1" NPT	10615K	10999	11068	10927	4257
Model 220,270,300,350		B04	O	E35	1" NPT	1" NPT	10615K	10999	11068	10927	4257
Model 220,270,300,350	40070	P102	O	P105	1 1/4"	1 1/4"	10615K	10615K	19354	18652	8490
Model 220,270,300,350		R101	O		1" NPT	1" NPT	10615K		*	10927	4257
Model 220,270,300,350	40050	P101	P	P1014	1 1/4"	1 1/4"	10615K	19301	25029	12859	(2) 23448
Chevy V6	97512	H10	O	*	1"	1"	09959K	23979	12665	12859	(2) 23448
<b>ESCORT (SKILTEC)</b>											
302 and 351		F75	O	*	1" NPT	1" NPT	10615K			10927	4257
302 and 351	D5MZ8502	G85	O		1 1/4"	1 1/4"	10615K	23976	23977	12859	(2) 23448
<b>GLASTRON BOAT CO.</b>											
121, 182, and 302 CI		G95-1	O		1"	1"	09959K	23979	12665	12859	(2) 23448
<b>GRAY MARINE</b>											
4 Cyl	G78478	N10510G	O	*	-	-	09959K			10545	4257
4 Cyl	G78972	P10650G	O	*	-	-	09959K		*	10545	4257
4 Cyl	G77560	L9930G	O	*	3/4" NPT	3/4" NPT	09959K			10545	4257
6 Cly	G77160	K9615G	O	*	-	-	09731			10545	4257
6 Cly	G77475	M10065G	O	*	-	-	09959K			10545	4257
6 Cly	G77560	L9930G	O	*	-	-	09959K			10545	4257
Fireball V8 (CW Rotation)	G75842	K9529G	O	*	-	-	09745			10545	4257
Fireball V8 (CW Rotation)	G77532	L9850G	O	*	-	-	09745			10545	4257
Fireball V8 (CW Rotation)	G80785	R10925G	O	*	-	-	09959K			10545	4257
Fireball V8 (CW Rotation)	G77586	M10180G	O	*	-	-	(2)09959K			10545	4257
Fireball V8 (CCW Rotation)	G80784	R10920G	O	*	-	-	09959K			10545	4257
Fireball V8 (CCW Rotation)	G77585	L9920G	O		-	-	(2)09959K			10545	4257
Compact V8 215,225 CCW	G80301	N10460	O	*	-	-	09959K			10513/10514	4257
Compact V8 215,225 CW	G80300	N10470	O	*	3/4" NPT	3/4"	09959K			10513/10514	4257
Gov Engine	G76647	Q10770G	O	*	-	-	09959K	09959K		10545	4257
Gov Engine	G80971	R10955G	O	*	-	-	09959K	09959K		10545	4257
Gov Engine	G85106	R10970G	O	*	-	-	10615K	10999		10927	4257
Gov Engine	G80561	Q10840	O	*	1/2" NPT	1/2" NPT	10077K			10859/11628C	(2) 4306
Gov Engine	G80953	R10945CC	O	*	1 1/2"	1 1/4"	*	12249		10577	
Gov Engine	G80954	R10950C	O	*	1 1/2"	1 1/4"	10635	12249		10577	
<b>INTERCEPTOR</b>											
		M10210G	O	P10700G	-	-	09959K	09959K	12252	10545	4257
		N10410G	O	P10700G	-	-	09959K	09959K	12252	10545	4257
		P10700G	O		3/4" NPT	3/4" NPT	09959K	09959K	12252	10545	4257
		F15	O	R50G	3/4" NPT	3/4" NPT	09959K			10927	4257
<b>ISUZU</b>											
4, 6 Cly Diesel	X-26230-1023	K90	S		1 1/4"	1 1/4"	10615K	23976	23977	12859	(2) 23448
<b>KOHLER</b>											
4, 6 Cly Diesel		G906P	O	**	3/8" NPT	3/8" NPT	09000K	25195	25196	18570	(2) 23448
Ford		G907P-01	S	G907P	3/8" NPT	3/8" NPT	09000K	25195	25196	22546	(2) 23448
4-6.5 KW Gas		G907-01	S	G907P	3/8" NPT	3/8" NPT	09000K	25195	25196	22546	(2) 23448
<b>LENCO</b>											
	L90	O	G7		1 1/4"	1 1/4"	10615K	23976	23977	12859	(2) 23448

\*\* Kohler Replacement for "G-906P with pulley" is G-907P; "without pulley", use G-906.



SHAFT	CAM	GASKET / O-RING	BUSHING	BODY	CAM SCREW	COVER	HOUSING	WEAR PLATE	KEY	PIN	SLINGER	RETAINING RING	PULLEY / GEAR / HUB / ADAPTER
*	15883	*	6333	*	10515C	*	*		4432	1311		(2) 4258/4259	
10748	*	10752	6333	*	10822	*	*		4432	1311		(2) 4258/4259	
10748	*	10752	6333	*	10822	*	*		4432	1311		(2) 4258/4259	
10256	10072	10103	6333	*	9919	10094		10254	4432	1311		4258/4259	
10256	10072	10103	6333	*	9919	10094		10254	4432	1311		4258/4259	
10256	10072	10103	6333	*	9919	10094		10254	4432	1311		(2) 4258/4259	
10852	10072	10103	6333	10176	9919	10094	15104		(2) 4432	1311		(3) 4258/4259	
*	10944	10931	6333	*	10515C	10182			4432	1311		4258/4259	97176
11744	10944	10931	6333	11245	10515C	10182			4432	1311		4258/4259	97176
19308	10944	12231		21378	10515C	21120			4432			5126/6837	19275
*	10944	12231	6333		10515C	*	*		12841			(3) 4258/4259 (1)	
19293	10944	19251		24107***	10515C	23946		19295	4432			(2) 4258/4259 (1)	97176
12596	15883	12231/12855		12328	10515C		12303	12856	4432			(2) 4258/4259 (2)	97176
*	10944	10971	6333		10515C	10182	*	*	4432	1311		(2) 4258/4259	10769
12596	10944	12231/12855		12328	10515C		12228	12856	4432	9420		(3) 4258/4259 (2)	10769
*	15883	12231/12855		12328	10515C		12303	12856	4432	*		(3) 4258/4259 (2)	*
*	10072	10103	6333	*	9919	10094	*		4432	1311		4258/4259	
*	10072	10103	6333	*	9919	10094	*		4432	1311		4258/4259	*
*	10072	10103	6333	*	9919	10094			4432	1311		4258/4259	
*	*	9484	6333	*	*	*		*		1311		4258/4259	*
*	10072	9484	6333	*	9919	*		*	4432	1311		4258/4259	
*	10072	10103	6333	*	9919	10094			4432	1311		4258/4259	
*	*	9484	6333	*	*	*	*	*		*		4258/4259	*
*	*	9484	6333	*	*	*	*	*		413		4258/4259	*
*	10072	(2) 10103	6333	*	9919	10094	*	*	4432	413		4258/4259	*
*	(2) 10072	(2) 10103	6333	*	9919	10094	*	*	4432	413		4258/4259	*
*	10072	(2) 10103	6333	*	9919	10094	*	*	4432	413		4258/4259	*
*	(2) 10072	(2) 10103	6333	*	9919	10094	*	*	4432	413		4258/4259	*
*	10072	10512C		*	10515C	*	*		4432	1311	*	5328/4259	*
*	10072	10512C		*	10515C	*	*		4432	1311	*	5328/4259	*
*	10072	10103	6333	*	10515C	10094			4432	1311		(3) 4258/4259	
*	10072	10103	6333	*	10515C	10094			4432	1311		(3) 4258/4259	*
*	10929	10931	6333	*	10515C	10182			4432	1311	7070	4258/4259	*
10858	10285	10286		*	10195	10593			10093	*	*	4303/4304	*
14055		10575				*	*				*	10574	*
14055		10575				*	*				*	10574	*
10256	10072	10103	6333	*	9919	10094		10254	4432	1311		4258/4259	
10256	10072	10103	6333	*	9919	10094		10254	4432	1311		4258/4259	
10256	10072	10103	6333	*	9919	10094		10254	4432	1311		(2) 4258/4259	
10852	10072	10103	6333	10176	9919	10094	15104		(2) 4432	1311		(3) 4258/4259	
12596	10944	12231/12855		12227	10515C		12228	12856	4432			(3) 4258/4259 (2)	*
18569	18663	19964			10195	24125	19963		13777			4258/4259	*
21861	18663	19964			10195	24125	21862		13777			(2) 4258/4259	21859
21861	18663	19964			10195	24125	21862		13777			(2) 4258/4259 (1)	
10944	12231/12855		12227	10515C		12228	12856	4432/12622	11541		12305 (2) 4258/4259	12326/12393	

ENGINE MANUFACTURER		SHERWOOD NUMBER	PUMP AVAIL	PREPLACEMENT PUMP	PORTS		IMPELLER KIT	MINOR REPAIR KIT	MAJOR REPAIR KIT	SEAL & SEAT/ LIP SEAL	BEARING ASSEMBLY	
ENGINE MODEL	ENGINE PART NO.				INLET	OUTLET						
MARINE CORP. OF AMER. (SEE STAR POWR)												
MARINE POWER												
	G157	S		1 1/2"	1 1/2"	15000K	23980	23981	12859	(2) 23448	21231	
	P105	S		1 1/4"	1 1/4"	10615K	10615K	19354	18652	8490	19308	
NORTH AMERICAN ENGINE												
	6.2L Diesel	G56	O		1 1/4"	1 1/4"	10615K	23976	23977	12859	(2) 23448	
ONAN												
	12MDJC-15 MDJF	RPGC	O	*	3/4" NPT	3/4" NPT	09959K	09959K	12246	10545	4306	
	30MDEH-50MDEG	RPGC	O	*	3/4" NPT	3/4" NPT	09959K	09959K	12246	10545	4306	
	4Cyl Diesel	K75	O	K75B	1"	1"	09959K	23979	12665	12859	(2) 23448	
	4Cyl Diesel	K75B	S		1"	1"	09959K	23979	12665	12859	(2) 23448	
	5Cyl Diesel	L10	O	L10B	1 1/4"	1 1/4"	10615K	23976	23977	12859	(2) 23448	
	5Cyl Diesel	L10B	S		1 1/4"	1 1/4"	10615K	23976	23977	12859	(2) 23448	
	5Cyl Diesel	G905	O		1"	1"	09000K			12859/18570	(2) 23448	
	5Cyl Diesel	G1004	O	G1010	1"	1"	10615K	10615K	22014	21208/21209	(2) 23448	
	5Cyl Diesel	G1005	O	G1010	1"	1"	10615K	10615K	22014	21208/21209	(2) 23448	
OSCO MOTORS												
		P105	S		1 1/4"	1 1/4"	10615K	10615K	19354	18652	8490	
OWENS FLAGSHIP MARINE												
	Model V8	6587	L9887	O	*	-	-			7269/10546	*	
		M10230	O	*	-	-			7269/10546	*	*	
		Q10750	O	*	-	-			10545	*	*	
OMC												
	In Board	981939	G45-2	O	G46	1 1/4"	1 1/4"	10615K	23976	23977	12859	(2) 23448
	V8 Chevy	981937	H-85	O		1 1/4"	1 1/4"	10615K	23976	23977	12859	(2) 23448
	V8 Chevy	985096	G46	O		1 1/4"	1 1/4"	10615K	23976	23977	12859	(2) 23448
	6-8 Cyl	3852398	G9901	S		1 1/4"	1"	09959K	23979	12665	12859	(2) 23448
	4Cyl	3852399	G9902	O	G9903	1 1/4"	1"	09959K	23979	12665	12859	(2) 23448
	4Cyl	3855079	G9903	S		1 1/4"	1"	09959K	23979	12665	12859	(2) 23448
PALMER												
	I.H. 60	E20	O	*	1/2" NPT	1/2" NPT	10077K			10859/11628	4306	
PATHFINDER VOLKSWAGON ENG												
	4 Cyl	J90	O	*	1"	1"	09959K			12859	*	
PERKINS ENGINE U.S.												
	40-107 Diesel	B06	O	G65	3/4" NPT	3/4" NPT	09959K	09959K	*	11237/10514	*	
	40-108 Diesel	NA003335	G65	S	3/4" NPT	3/4" NPT	09959K	09959K	12221	10514C	(2) 23448	
	4-154 Diesel	NA005576	H5	S	1"	1"	09959K		12980	10514/06602	(2) 4257	
	6-354 Diesel	NA001175	RPBC	S	1" NPT	1" NPT	10615K	10999	11068	10927	4257	
PLEASURECRAFT MARINE												
	Chevy 454	G55-2	S		1 1/4"	1 1/4"	10615K	23976	23977	12859	(2) 23448	
	302 and 351	G20	O	G21	1"	1"	09959K	23979	12665	12859	(2) 23448	
	302 and 351	G21-01	P	G21	1"	1"	09959K	23979	12665	12859	(2) 23448	
	Mitsubishi 4 Cyl	G22-01	P	*	-	-	09959K	23979	12665	12859	(2) 23448	
	7.3L Diesel	G26-01	P	*	1 1/4"	1 1/4"	10615K	23976	23977	12859	(2) 23448	

SHAFT	CAM	GASKET / O-RING	BUSHING	BODY	CAM SCREW	COVER	HOUSING	WEAR PLATE	KEY	PIN	SLINGER	RETAINING RING	PULLEY / GEAR / HUB / ADAPTER
18314	12231/12855		12227	10515C		17684	12856	4432			(3) 4258/4259 (2)		
10944	12231		21378	10515C	21120			4432			5126/6837	19275	
12596	10944	12855/12231		12328	10515C		12907	12856	4432	9420		(2) 4258/4259 (3)	10769
*	10072	10103	6333	*	9919	10094			4432	1311	14990	4258/5484	
*	10072	10103	6333	*	9919	10094			4432	1311	14990	4258/5484	
13363	15883	12231/12855		*	10515C		13793	12856	4432			(3) 4258/4259 (2)	13795
13363	15883	12231/12855		19948	10515C		13793	12856	4432			(3) 4258/4259 (2)	13795
13363	10929	12231/12855		*	10515C		13899	12856	4432			(3) 4258/4259 (2)	13795
13363	10929	12231/12855		19948	10515C		13899	12856	4432			(3) 4258/4259 (2)	13795
*		(2)19964/*		*		*	*	*				(3) 4258/4259	
21207	10929	12231		*	10515C	21173	21150	21163	4432			4258/4259 (2)	
21207	10929	12231		*	10515C	21173	21150	21163	4432			4258/4259 (2)	
19308	10944	12231		21378	10515C	21120			4432			5126/6837	19275
*		(2) 5248	2075/*	*	*	*	*	*	17658	1311		4304	*
	*	2075/*	*	*	*	*	*	*	17658	1311	4304	*	
	*	6333 (2)/*	*	*	*		*	17658	1311		4304	*	
12233	10929	12231/12855		12328	10515C		12952	12856	4432/12622	11541		(2) 4258/4259 (2)	12326
12596	10929	12231/12855		12328	10515C	*	12952	12856	4432			(3) 4258/4259 (2)	*
13363	10929	12231/12855		12328	10515C		12952	12856	4432			(3) 4258/4259 (2)	15048
13363	15883	12231/12855		21153	10515C		21151		4432			(3) 4258/4259	21154
13363	15883	12231/12855		21153	10515C		21151		4432			(3) 4258/4259	21175
13363	15883	12231/12855		21759	10515C		21151		4432			(3) 4258/4259	21175
11747	10285	10286		*	10195	10593			10093			4303/4304	
*	*	*	*		9919	*	*		4432	*		4258/12840	
*	10072	11360		*	10515C	11389			4432				
12444	10072	11360		12440	10515C	11389			4432				
13272	15883	12231		11794	10515C	11795			4432/13271			4259/12582	
11374	10944	10931	6333	11370	10515C	10182			4432/10093	(2) 1311	14990	(3) 4258/4259 (1)	
12596	10944	12231/12855		12328	10515C		12907	12856	4432	9420		(3) 4258/4259 (2)	12926
12367	15883	12231/12855		12328	10515C		12303	12856	4432/12622	11541		4259/4258/12305	*
13363	15883	12231/12855		12328	10515C		12303	12856	4432			(3) 4258/4259 (2)	19729
13363	15883	12231/12855		*	10515C		12303	12856	4432			(3) 4258/4259 (2)	15055
13363	10944	12231/12855		*	10515C		12228	12856	4432			(3) 4258/4259 (2)	19729

ENGINE MANUFACTURER		SHERWOOD NUMBER	PUMP AVAIL	PREPLACEMENT PUMP	PORTS		IMPELLER KIT	MINOR REPAIR KIT	MAJOR REPAIR KIT	SEAL & SEAT/ LIP SEAL	BEARING ASSEMBLY
ENGINE MODEL	ENGINE PART NO.				INLET	OUTLET					
<b>STARPOWER</b>											
Inboard		G151	S		1 1/2"	1 1/2"	15000K	23980	23981	12859	(2) 23448
Stern Drive	800790MI	G155	S		1 1/2"	1 1/2"	15000K	23980	23981	12859	(2) 23448
<b>UNIVERSAL MEDALIST</b>											
Atomic Four		L9960	O	T11165	-	-	09979			*	
Atomic Four		T11165	O	*	3/8"	3/8"	09979	*		10514C	
Utility Four		T11166	O	*	-	-	09979	*		10514C	
Model OK-OL		L9790G	O	*	-	-	*			10546	4306
Model OK-OL		Q10805G	O	*	3/8"	3/8"	10077K			10546	4306
Sabre V6		R10930G	O	*	3/4"	3/4"	09959K	10997		10545	4257
Light Plants		E05	O	R30G	1/2"	1/2"	10077K	10996	24025	11367	4306
Light Plants		R10870G	S	R50G	3/4" NPT	3/4" NPT	09959K	10997	12937	10927	4257
Light Plants	299805	H80A	O	G908-01	3/8"	3/8"	12336	11876		(2) 10514C	
Light Plants	300986	M5	O	G908-01	3/8"	3/8"	12336	11876		(2) 10514C	
Light Plants	302648	G903	O	G908-01	1/2"	1/2"	09000K			12859/18806	(2) 23448
<b>U.S. MARINE</b>											
351 Ford		P151	O		1 1/4"	1 1/4"	15000K			18652	(2) 18662
<b>VOLVO PENTA</b>											
		G30-2	O	G30-2B	1"	1"	09959K	23979	12665	12859	(2) 23448
		G85	O		1 1/4"	1 1/4"	10615K	23976	23977	12859	(2) 23448
		P105	S		1 1/4"	1 1/4"	10615K	10615K	19354	18652	8490
6-8 Cyl	3852398	G9901	S		1 1/4"	1"	09959K	23979	12665	12859	(2) 23448
4Cyl	3852399	G9902	O	G9903	1 1/4"	1"	09959K	23979	12665	12859	(2) 23448

SHAFT	CAM	GASKET / O-RING	BUSHING	BODY	CAM SCREW	COVER	HOUSING	WEAR PLATE	KEY	PIN	SLINGER	RETAINING RING	PULLEY / GEAR / HUB / ADAPTER
25057	18314	12231/12855		12227	12857		17684	12856	4432			(3) 4258/4259 (2)	15055
25057	18314	12231/12855		12227	12857		19880	12856	4432			(3) 4258/4259 (2)	15055
*	*	*		*	*	*					*		
*	*	*		*	*	*							
*	*	*		*	*	*							
*	*	9484	2075	*	*	*		*		*	7070		*
*	10285	10286	2075	*	10195	10279			10093	1311	7070	4304	
*	*	10103	6333	*	*	10094	*		4432	1311		4258/4259	
10289	10285	10197/10286	2075	10596	10195	10279			10093	1311		4303/4304	
*	10072	10171/10103	6333	*	9919	10094	15104		4432/12622	1311		4258/4259	
11873	*	10286	11519	*	10822	10593			10093			12863	
13833	*	10286	11519	*	10822	10593			10093			12863	
*	18663	12231/12855		*	10195		18451	12856	18576		1410-0056	(3) 4258/4259 (1)	
18671	18398	12231			10515C	18509	18660		4432		14990	6837/8781	*
12612	15883	12231/12855		12328	10515C	12856	12303	12856	4432	12791		(3) 4258/4259 (2)	12615
12596	10944	12231/12855		12328	10515C		12228	12856	4432	9420		(3) 4258/4259 (2)	10769
19308	10944	12231		21378	10515C	21120			4432			5126/6837	19275
13363	15883	12231/12855		21153	10515C		21151		4432			(3) 4258/4259	21154
13363	15883	12231/12855		21153	10515C		21151		4432			(3) 4258/4259	21175

SERVICE



SHERWOOD NUMBER	PUMP AVAIL	REPLACEMENT PUMP	PORTS		IMPELLER KIT	MINOR REPAIR KIT	MAJOR REPAIR KIT	SEAL & SEAT/ LIP SEAL	BEARING ASSEMBLY	SHAFT
			INLET	OUTLET						
0 G1	S		1"	1"	09959K	23979	12665	12859	(2) 23448	11877
G1006-01	O	G1010	1"	1"	10615K	10615K	22276	22117/21208	23448	22143
G1006	O	G1010	1"	1"	10615K	10615K	22276	22117/21208	23448	22143
G1008-01	O	G1010	1"	1"	10615K	10615K	22276	22117/21208	8490	23801
G1009-01	P	G1009	1 1/4"	1 1/4"	10615K	23976	23977	12859/10514C	23448	24628
G1009	S		1 1/4"	1 1/4"	10615K	23976	23977	12859/10514C	23448	24628
G1010-01	P	G1010	1"	1"	10615K		25073	22117/25067	12211	25068
G1010	S		1"	1"	10615K		25073	22117/25067	12211	25068
G11	S		1/2" NPT	1/2" NPT	09000K			12859	(2) 23448	21578
G1502	O		1 1/2"	1 1/2"	15000K	23980	23256	12966/12966	*	*
G1503	O		1 1/2"	1 1/2"	15000K	23980	23256	12859/12966	(2) 23448	23228
G1503-01	O		1 1/2"	1 1/2"	15000K	23980	23256	12859/12966	(2) 23448	23228
G1503-02	O		1 1/2"	1 1/2"	15000K	23980	23256	12859/12966	(2) 23448	23228
G1503-03	P		1 1/2"	1 1/2"	15000K			24054/12966	(2) 23448	23228
G1505-01	P	G1505	1 1/2"	1 1/2"	15000K			12859	(2) 2000-0008	25058
G1505	S		1 1/2"	1 1/2"	15000K			12859	(2) 2000-0008	25058
G1508-01	P	G1508	1 1/2"	1 1/2"	15000K	23980	23981	12859	(2) 12211	25057
G1508	S		1 1/2"	1 1/2"	15000K	23980	23981	12859	(2) 12211	25057
G151	S		1 1/2"	1 1/2"	15000K	23980	23981	12859	(2) 23448	25057
G155	S		1 1/2"	1 1/2"	15000K	23980	23981	12859	(2) 23448	25057
G1801	O		2 1/2"	2"	18000K	18000K	*	19878/19869	24000 Shaft Bearing Assy	
G1804	O		2 1/2"	2"	18000K	24004	24006	19878/19869	24001 Shaft Bearing Assy	
G1805	P		2 1/2"	2"	18000K	24023	24024	19878/19869	24000 Shaft Bearing Assy	
G1806	O		2 1/2"	2 1/2"	18000K	24004	24006	19878/19869	24001 Shaft Bearing Assy	
G18061-01	P		2 1/2"	2 1/2"	18000K	24004	24006	23837/19869	24001 Shaft Bearing Assy	
G1807	O	G18071X	2 1/2"	2"	18000K	24023	24024	19878/19869	25112 Shaft Bearing Assy***	
G18071-01	O	G2904X	2 1/2"	2"	18000K	24023	24024	23837/19869	25112 Shaft Bearing Assy***	
G18071X	O	G2904X	W/O Port Elbow	W/O Port Elbow	18000K	24023	24024	23837/19869	25112 Shaft Bearing Assy***	
G1808	O		3 3/4"	3 3/4"	18000K	24004	24007	19878/23045	24002 Shaft Bearing Assy	
G18081-01	P		3 3/4"	3 3/4"	18000K	24004	24007	23837/23045	24002 Shaft Bearing Assy	
G18082-01	O	G2902X	3 3/4"	3 3/4"	18000K	24004	24007	23837/23045	24463 Shaft Bearing Assy	
G18082X	O	G2902X	3 3/4"	3 3/4"	18000K	24004	24007	23837/23045	24463 Shaft Bearing Assy	

\* Assembly includes bearings pressed onto the shaft along with the appropriate spacers, washers and retaining rings.

\*\*\* The 29000 impeller must be used with the 25112 shaft replacement. The change effectively converts the pump to a G2904X.

26 \*\*\*\* The 29000 impeller must be used with the 25103 shaft replacement (the major kit 25045 contains the 29000 impeller and 25103 shaft bearing assembly as well). The change effectively converts the pump to a G2903X.

# Other OEM and General Service Pumps

CAM	GASKET / O-RING	BUSHING	BODY	CAM SCREW	COVER	HOUSING	WEAR PLATE	KEY	PIN	SLINGER	HUB/ ADAPT	RETAINING RING	PULLEY / GEAR
15883	12231/12855		12227	10515C		12303	12856	04432/12622				(3) 4258/4259 (2)	
10929	(2) 12231	6333	22141	10515C	22140	21150	22142	4432	(4) 21056			(3) 4258/4259 (2)	
10929	(2) 12231	6333	22141	10515C	22140	21150	22142	4432	(4) 21056			(3) 4258/4259 (2)	
10929	(2) 12231	6333	23798	10515C	22140	21150	22142	4432	(4) 21056			04258/05126/06837	
10944	12231/12855		24624	10515C		12228	12856	4432				(1)4258/(1)4259/(2)14161	
10944	12231/12855		24624	10515C		12228	12856	4432				(1)4258/(1)4259/(2)14161	
10929	12231		25065	19714	25069	25066	19295	4432		24930		(2) 4258	25071
10929	12231		25065	19714	25069	25066	19295	4432		24930		(2) 4258	25071
18663	12231/12855		12227	10195		18451	12856	12622/18576				(3) 4258/4259 (2)	
	12231		22635		21173	*	22836	4432				(2) 4258/4259 (1)	23870
	12231		23231		21173	23230	22836	4432				(2) 4258/4259 (1)	23870
	12231		23231		21173	23230	22836	4432				(2) 4258/4259 (1)	23870
	12231		23231		21173	23230	22836	4432				(2) 4258/4259 (1)	23870
	12231		23231		21173	23230	22836	4432				(2) 4258/4259 (1)	23870
18314	12231		25059	10515C		19880	12856	4432		24629		(1)4258/(1)24940/(2)24939	25114
18314	12231		25059	10515C		19880	12856	4432		24629		(1)4258/(1)24940/(2)24939	25114
18314	12231		25051	10515C		19880	12856	4432		24629		(2) 4258/4259 (2)	
18314	12231		25051	10515C		19880	12856	4432		24629		(2) 4258/4259 (2)	
18314	12231/12855		12227	12857		17684	12856	4432				(2) 4258/4259 (2)	
18314			12227	12857		19880	12856	4432				(2) 4258/4259 (2)	
19829	19879		*		19837	*	19836			19868		(2) 19762/19867 (1)	
(2) 21533	(2) 21561		*		19837	*	19836		21566	19868		(2) 19762/19867 (1)	
(2) 21106	(2) 21561		22125		19837	21829	19836		21566	19868		(2) 19762/19867 (1)	
(2) 21533	(2) 21561		21986		19837	21829	19836		21566	19868		(2) 19762/19867 (1)	
(2) 21533	(2) 21561		21986		19837	21829	19836		21566	19868		(2) 19762/19867 (1)	
(2) 21106	(2) 21561		21827		19837	21829	19836		21566	19868		(2) 19762/19867 (1)	
(2) 21106	(2) 21561		21827		19837	21829	19836		21566	19868		(2) 19762/19867 (1)	
(2) 21106	(2) 21561		21827		19837	21829	19836		21566	19868		(2) 19762/19867 (1)	
(2) 21533	(2) 21561		22412		19837	24623	19836	22791	21566	19868		(2) 19762/19867 (1)	22789
(2) 21533	(2) 21561		22412		19837	24623	19836	22791	21566	19868		(2) 19762/19867 (1)	22789
(2) 21533	(2) 21561		23916		19837	24623	19836	22791	21566	19868		(2) 19762/19867 (1)	22789
(2) 21533	(2) 21561		23916		19837	24623	19836	22791	21566	19868		(2) 19762/19867 (1)	22789

SHERWOOD NUMBER	PUMP AVAIL	REPLACEMENT PUMP	PORTS		IMPELLER KIT	MINOR REPAIR KIT	MAJOR REPAIR KIT	SEAL & SEAT/ LIP SEAL	BEARING ASSEMBLY	SHAFT
			INLET	OUTLET						
G1810-01	O	G2903X	2 1/2"	2"	18000K	24005	24008	23512/23045	24003 Shaft	Bearing Assy
G1810X	O	G2903X	W/O Port Elbow	W/O Port Elbow	18000K	24005	24008	23512/23045	24003 Shaft	Bearing Assy
G1811-01	P	G1816X	2 1/2"	2"	18000K	24005	24008	23512/23045	24003 Shaft	Bearing Assy
G1814-01	O	G2903X	2 1/2"	2"	24654		25045****	24511/23045	25103 Shaft	Bearing Assy****
G1814X	O	G2903X	W/O Port Elbow	W/O Port Elbow	24654		25045****	24511/23045	25103 Shaft	Bearing Assy****
G1815-01	P	G1815X	2 1/2"	W/O Port Elbow	18000K	24753	24754	23512/19869	24003 Shaft	Bearing Assy
G1815X	S		W/O Port Elbow	W/O Port Elbow	18000K	24753	24754	23512/19869	24003 Shaft	Bearing Assy
G1816-01	P	G1816X	2 1/2"	W/O Port Elbow	18000K	24760	24761	23512/23045	24003 Shaft	Bearing Assy
G1816X	S		W/O Port Elbow	W/O Port Elbow	18000K	24760	24761	23512/23045	24003 Shaft	Bearing Assy
G2	S		1"	1"	09959K	23979	12665	12859	(2) 23448	11877
G2201-01	O		3 3/4"	3 3/4"	22000K	23234	*	23087/23088	(2)23089	23058
G22011-01	P		3 3/4"	3 3/4"	22000K	23234	*	23906/23088	24464 Shaft	Bearing Assy
G22012-01	O	G3001X	3 3/4"	3 3/4"	22000K	23234	*	23906/23088	24465 Shaft	Bearing Assy
G22012X	O	G3001X	3 3/4"	3 3/4"	22000K	23234	*	23906/23088	24465 Shaft	Bearing Assy
G2601-01	O	G2603X	2 1/2"	W/O Port Elbow	26000K	24227	24228	23837/19869	24223 Shaft	Bearing Assy
G2601X	O	G2603X	W/O Port Elbow	W/O Port Elbow	26000K	24227	24228	23837/19869	24223 Shaft	Bearing Assy
G2602-01	O	G2603X	2 1/2"	W/O Port Elbow	26000K	24227	24228	23837/19869	24223 Shaft	Bearing Assy
G2603-01	P	G2603X	2 1/2"	W/O Port Elbow	26000K	24841	24842	23837/19869	24223 Shaft	Bearing Assy
G2603X	S	G2603X	W/O Port Elbow	W/O Port Elbow	26000K	24841	24842	23837/19869	24223 Shaft	Bearing Assy
G2605-01	P	G2603X	2 1/2"	W/O Port Elbow	26000K	24841	24842	23837/19869	24223 Shaft	Bearing Assy
G2902-01	P	G2902X	3 3/4"	3 3/4"	29000K	25146	25147	23837/23045	25145 Shaft	Bearing Assy
G2902X	S		3 3/4"	3 3/4"	29000K	25146	25147	23837/23045	25145 Shaft	Bearing Assy
G2903-01	P	G2903X	2 1/2"	2"	29000K	25044	25045	24511/23045	25103 Shaft	Bearing Assy
G2903X	S		W/O Port Elbow	W/O Port Elbow	29000K	25044	25045	24511/23045	25103 Shaft	Bearing Assy
G2904-01	P	G2904X	2 1/2"	2"	29000K	25146	25148	23837/19869	25112 Shaft	Bearing Assy
G2904X	S		W/O Port Elbow	W/O Port Elbow	29000K	25146	25148	23837/19869	25112 Shaft	Bearing Assy
G3	S		1-1/4"	1-1/4"	10615K	23976	23977	12859	(2) 23448	11877
G3001-01	P	G3001X	3 3/4"	3 3/4"	30000K	25017	25154	23906/23088	25153 Shaft	Bearing Assy
G3001-02	P	G3001X	3 3/4"	3 3/4"	30000K	25017	25154	23906/23088	25153 Shaft	Bearing Assy
G3001X	S		3 3/4"	3 3/4"	30000K	25017	25154	23906/23088	25153 Shaft	Bearing Assy
G4	S		1-1/4"	1-1/4"	10615K	23976	23977	12859	(2) 23448	11877
G701-01	O	G702	1"	1"	10077K		22784	24934/21751	(2) 23448	22769

\* Assembly includes bearing pressed onto the shaft along with the appropriate spacers, washers and retaining rings.

\*\* The 25115 seal kit must be used with the 25119, 25120, and 25100 shaft bearing upgrade. The change converts the pumps to a P17xxC or P2708X and the 15955 or 23799 seals will not work with these upgraded shaft/bearing assemblies.

\*\*\*\* The kit is fitted with 24162. In some instances the 24162 wearplate will not fit. In the P1716 and P1722 pumps, the pin hole may be too shallow and the wearplate does not lay flat against the bottom of the housing bore.

In these instances use the 18441 wearplate with the smaller pin.

CAM	GASKET / O-RING	BUSHING	BODY	CAM SCREW	COVER	HOUSING	WEAR PLATE	KEY	PIN	SLINGER	HUB/ ADAPT	RETAINING RING	PULLEY / GEAR
(2) 21106	1720-0212		23396		19837	23523	19836		21566	19868		(2) 19762/19867 (1)	
(2) 21106	1720-0212		23396		19837	23523	19836		21566	19868		(2) 19762/19867 (1)	
(2) 21106	1720-0212		24174		19837	23523	19836		21566	19868		(2) 19762/19867 (1)	
(2) 21106	1720-0212		23396		19837	23523	19836		21566	19868		(2) 19762/19867 (1)	
(2) 21106	1720-0212		23396		19837	23523	19836		21566	19868		(2) 19762/19867 (1)	
(2) 21533	1720-0212		24174		19837	23523	19836		21566	19868		(2) 19762/19867 (1)	
(2) 21533	1720-0212		24174		19837	23523	19836		21566	19868		(2) 19762/19867 (1)	
(2) 21533	1720-0212		24174		19837	23523	19836		21566	19868		(2) 19762/19867 (1)	
(2) 21533	1720-0212		24174		19837	23523	19836		21566	19868		(2) 19762/19867 (1)	
15883	12231/12855		12227	10515C		11903	12856	04432/12622				(3) 4258/4259 (2)	
(2) 25072	23111		23056		23113	24229	23112		21566			1810-0012/23091/23115	23181
(2) 25072	23111		23056		23113	24229	23112		21566			1810-0012/23091/23115	23181
(2) 25072	23111		23919		23113	24159	23112		21566			1810-0012/23091/23115	23181
(2) 25072	23111		23919		23113	24159	23112		21566			1810-0012/23091/23115	23181
24075	19879		24102	19714	24074	24072	24073			24079		(2) 19762/19867 (1)	24083
24075	19879		24102	19714	24074	24072	24073			24079		(2) 19762/19867 (1)	24083
24075	19879		24102	19714	24074	24072	24073			24079		(2) 19762/19867 (1)	24083
24075	19879		24102	19714	24074	24072	24790			24079		(2) 19762/19867 (1)	24083
24075	19879		24102	19714	24074	24072	24790			24079		(2) 19762/19867 (1)	24083
24075	19879		24102	19714	24074	24072	24790			24079		(2) 19762/19867 (1)	24083
(2) 21533	(2) 21561		23916		19837	24623	19836	22791	21566	19868		(2) 19762/19867 (1)	22789
(2) 21533	(2) 21561		23916		19837	24623	19836	22791	21566	19868		(2) 19762/19867 (1)	22789
(2) 21106	1720-0212		23396		19837	23523	19836		21566	19868		(2) 19762/19867 (1)	
(2) 21106	1720-0212		23396		19837	23523	19836		21566	19868		(2) 19762/19867 (1)	
(2) 21106	(2) 21561		21827		19837	21829	19836		21566	19868		(2) 19762/19867 (1)	
(2) 21106	(2) 21561		21827		19837	21829	19836		21566	19868		(2) 19762/19867 (1)	
10944	12231/12855		12227	10515C		12228	12856	04432/12622				(3) 4258/4259 (2)	
(2) 25072	23111		23919		23113	24159	23112		21566			1810-0012/23091/23115	23181
(2) 25072	23111		23919		23113	24159	23112		21566			1810-0012/23091/23115	23181
(2) 25072	23111		23919		23113	24159	23112		21566			1810-0012/23091/23115	23181
10944	12231/12855		12227	10515C		12907	12856	04432/12622				(3) 4258/4259 (2)	
	21303/22770		*		22767	*	22768	10093				4258/4259	



SHERWOOD NUMBER	PUMP AVAIL	REPLACEMENT PUMP	PORTS		IMPELLER KIT	MINOR REPAIR KIT	MAJOR REPAIR KIT	SEAL & SEAT/ LIP SEAL	BEARING ASSEMBLY	SHAFT
			INLET	OUTLET						
G702	S		1"	1"	10077K			24934/21751	(2) 23448	22769
G702-01	P	G702	1"	1"	10077K			24934/21751	(2) 23448	22769
G8	O		1-1/4"	1-1/4"	10615K	23976	23977	12859	(2) 23448	11877
G8001-01	P	G8001	3/8" NPT	3/8" NPT	08000K			23459	(2) 23323	23445
G8001	S		3/8" NPT	3/8" NPT	08000K			23459	(2) 23323	23445
G8002-01	P	G8002	3/8" NPT	3/8" NPT	08000K			23459	(2) 23448	23679
G8002	S		3/8" NPT	3/8" NPT	08000K			23459	(2) 23448	23679
G8005-01	P	G8005	3/4"	3/4"	08000K			23459	(2) 23323	24914
G8005	S		3/4"	3/4"	08000K			23459	(2) 23323	24914
G907	O	G907P	3/8" NPT	3/8" NPT	09000K	25195	25196	22546	(2) 23448	21861
G907P	S		3/8" NPT	3/8" NPT	09000K	25195	25196	22546	(2) 23448	24124
G909-01	P		3/8" NPT	3/8" NPT	09000K	25195	25196	22546	(2) 23448	24171
G910P	S		3/8" NPT	3/8" NPT	09000K	25195	25196	22546	(2) 23448	24569
G910P-01	P	G910P	3/8" NPT	3/8" NPT	09000K	25195	25196	22546	(2) 23448	24569
GC1	S		1 1/2"	1 1/2"	15000K	23980	23981	12859/10514C	(2) 23448	21069
GC1-01	P	GC1	1 1/2"	1 1/2"	15000K	23980	23981	12859/10514C	(2) 23448	21069
GC4	O	GC5	1 1/2"	1 1/2"	15000K	23980	23981	12859/10514C	(2) 23448	21069
GC5	S		1 1/2"	1 1/2"	15000K	23980	23981	12859/10514C	(2) 23448	19843
GC5-01	P	GC5	1 1/2"	1 1/2"	15000K	23980	23981	12859/10514C	(2) 23448	19843
GP8001-01	O	G8001	3/8" NPT	3/8" NPT	8000K			23459	(2) 23323	23445
GP8002-01	O	G8002	3/8" NPT	3/8" NPT	8000K			23459	(2) 23448	23679
M71	S		1 1/4"	1 1/4"	10615K	23976	23977	12859/10514C	(2) 23448	14159
M71-01	P	M71	1 1/4"	1 1/4"	10615K	23976	23977	12859/10514C	(2) 23448	14159
P105-01	P	P105	1 1/4"	1 1/4"	10615K	10615K	19354	18652	(2) 08490	19308
P105	S		1 1/4"	1 1/4"	10615K	10615K	19354	18652	(2) 08490	19308
P109-01	P	P110	1 1/4"	1 1/4"	10615K	10615K	19354	18652	(2) 08490	19308
P110	S		1 1/4"	1 1/4"	10615K	10615K	19354	18652	(2) 08490	19308
P1012-01	P	P1014	1 1/4"	1 1/4"	10615K	19301	25029	12859	(2) 23448	19293
P1014	S		1 1/4"	1 1/4"	10615K	19301	25029	12859	(2) 23448	19293
P1015-01	P	P1014	1 1/4"	1 1/4"	10615K	19301	25029	12859	(2) 23448	19293
P1016-01	P	P1016	1 1/2"	1 1/2"	10615K	23976	25009	12859	(2) 23448	24885
P1016	S		1 1/2"	1 1/2"	10615K	23976	25009	12859	(2) 23448	24885
P1017-01	P	P1017	1 1/4"	1 1/4"	10615K		25108	22117	(2) 12211	25113
P1017	S		1 1/4"	1 1/4"	10615K		25108	22117	(2) 12211	25113
P1505-01	P	P1505	1 1/2"	1 1/2"	15000K		25089	12859	2000-0008	24936
P1505	S		1 1/2"	1 1/2"	15000K		25089	12859	2000-0008	24936
P171	O	P176X	1 3/4"	1 3/4"	17000K	23973	23975	15955	(2) 15951	*
P1710-02	O	P1710C	W/O Port Elbow	W/O Port Elbow	17000K	23973	25121	15955/21776	25119 Shaft Bearing Assy**	
P1710-04	P	P1710C	W/O Port Elbow	W/O Port Elbow	17000K	25123	25121	25115/21776	25119 Shaft Bearing Assy	
P1710A	O	P1710C	W/O Port Elbow	W/O Port Elbow	17000K	23973	25121	15955/21776	25119 Shaft Bearing Assy**	
P1710C	S		W/O Port Elbow	W/O Port Elbow	17000K	25123	25121	25115/21776	25119 Shaft Bearing Assy	
P1710X	O	P1710C	W/O Port Elbow	W/O Port Elbow	17000K	23973	25121	15955/21776	25119 Shaft Bearing Assy**	
P1711	O	P1719X	W/O Port Elbow	W/O Port Elbow	17000K	23972	23974	15955/19674	(2) 15951	19345
P1712	O	P1716C	1 3/4"	1 3/4"	17000K	23972	23974	15955/19674	(2) 15951	16046
P1716B-01	O	P1716C	2"	1 3/4"	17000K	23972*****	25122*****	15955/19674	25120 Shaft Bearing Assy**	
P1716B-02	O	P1716C	2"	1 3/4"	17000K	23972*****	25122*****	15955/19675	25120 Shaft Bearing Assy**	
P1716-04	P	P1716C	2"	1 3/4"	17000K	25124	25122	25115/19675	25120 Shaft Bearing Assy	
P1716A	O	P1716C	2"	1 3/4"	17000K	23972*****	25122*****	15955/24250	25120 Shaft Bearing Assy**	
P1716C	S		2"	1 3/4"	17000K	25124	25122	25115/19675	25120 Shaft Bearing Assy	

CAM	GASKET / O-RING	BUSHING	BODY	CAM SCREW	COVER	HOUSING	WEAR PLATE	KEY	PIN	SLINGER	HUB/ ADAPT	RETAINING RING	PULLEY / GEAR
	21303/22770		24525			24524	24526	10093				4258/4259	
	21303/22770		24525			24524	24526	10093				4258/4259	
10929	12231/12855		*	10515C		*	12856	04432/12622				(3) 4258/4259 (2)	
	23447		23354		23366	24100						(1) 23325/23443 (1)	
	23447		23354		23366	24100						(1) 23325/23443 (1)	
	23447		23678		23366	24100						(1) 04258/04259 (1)	23680
	23447		23678		23366	24100						(1) 04258/04259 (1)	23680
	23447		24909		24912	25020	24910			13313		(1)24941/(1)23443/(1)23325	24917
	23447		24909		24912	25020	24910			13313		(1)24941/(1)23443/(1)23325	24917
18663	19964			10195	24125	24627		18576				(2) 4258/4259	
18663	19964			10195	24125	24627		18576				(2) 4258/4259	21859
18663	19964			10195	24125	21862		13777				(2) 4258/4259	
18663	19964			10195	24125	24627		18576				(2) 4258/4259	24589
18663	19964			10195	24125	24627		18576				(2) 4258/4259	24589
18398	12231/12855		14160	10515C		17684	12856	4432			18681	4258/14161/4259 (2)	14184
18398	12231/12855		14160	10515C		17684	12856	4432			18681	4258/14161/4259 (2)	14184
18398	12231/12855		14160	10515C		17684	12856	4432			*	4258/14161/4259 (2)	14184
18398	12231/12855		19907	10515C		17684	12856	4432			21700	(2) 4258/4259	19884
18398	12231/12855		19907	10515C		17684	12856	4432			21700	(2) 4258/4259	19884
	23447		23354		23366	23352						23325/23443	
	23447		23678		23366	23352						04258/04259	23680
10944	12231/12855		14160	10515C		12228	12856	4432			18681	4258/14161/4259 (2)	14184
10944	12231/12855		14160	10515C		12228	12856	4432			18681	4258/14161/4259 (2)	14184
10944	12231			10515C	23912	21378		4432				5126/6837	
10944	12231			10515C	21120	21378		4432				5126/6837	
10944	12231			10515C	23912	23791		4432				05126/06837	23770
10944	12231			10515C	21120	23791		4432				05126/06837	23770
10944	19251		24107	10515C	23946		19295	4432				(2) 4258/4259 (1)	97176
10944	12231			10515C	21120	24107	19295	4432				(2) 4258/4259 (1)	97176
10944	12231			10515C	23912	24107	19295	4432				(2) 4258/4259 (1)	97176
10929	12231			24884	24887	24882	19295	4432		24930		(2) 4258/4259 (1)	24883
10929	12231			24884	24887	24882	19295	4432		24930		(2) 4258/4259 (1)	24883
10944	12231			19714	24887	25111	19295	4432		24629		(2) 4258/4259 (1)	25114
10944	12231			19714	24887	25111	19295	4432		24629		(2) 4258/4259 (1)	25114
18314	12231			10515C	24887	24935	19295	4432		24629		(1)4258/(1)24939/(1)24940	24938
18314	12231			10515C	24887	24935	19295	4432		24629		(1)4258/(1)24939/(1)24940	24938
18271	15945			19673	18742	*	24162	15948				(3) 15952/15942(1)	
18271	15945			19714	18742	24161	24162	19667		24156	19699	(3) 15952/15942 (1)	
18271	15945			19714	18742	24161	24162	25152		24156	19699	(2) 15952/15942 (1)	
18271	15945			19714	18742	24161	24162	19667		24156	19699	(3) 15952/15942 (1)	
18271	15945			19714	18742	*	24162	19209			*	(3) 15952	
18271	15945			19673	18742	*	24162	19209			*	(3) 15952/15942 (1)	14184
18271	21570/15945			19714	18742	19630	18441	19667		24156	19727	(3) 15952	22495
18271	21570/15945			19714	18742	19630	18441	19667		24156	19727	(2) 15952	22495
18271	21570/15945			19714	18742	19630	24162	19667		24156	19727	(2) 15952	22495
18271	21570/15945			19714	18742	19630	18441	19667		24156	19727	(2) 15952	22495
18271	21570/15945			19714	18742	19630	24162	19667		24156	19727	(2) 15952	22495

# 09959, 10615, and 15000 G Series Technical Guide

## Assembly/Disassembly Instructions

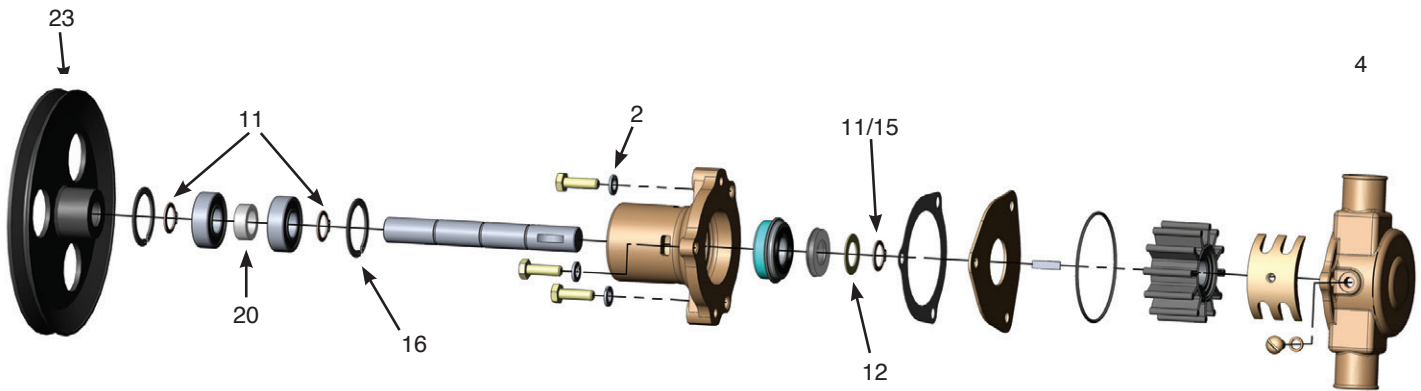

The following assembly/disassembly procedures apply to all G Series pumps. Deviations from pump to pump are primarily a result of different methods of drive and mounting.

### Disassembly:

- A. Remove the screws (1) and lockwashers (2) that hold the body (3) and housing (4) together.
- B. The housing assembly including the impeller (5) can be removed from the body assembly, along with the o-ring (6), spacer plate (7) and gasket (8).
- C. Remove the woodruff key (9) from the shaft (10). If the shaft is to be used again, and if it is put in a vise, always use lead over the jaws of the vise so that the shaft is not damaged.
- D. Remove the retaining ring (11 or 15) from the shaft (impeller end). The shoulder washer (12) and seat assembly (13) can now be removed.
- E. From the drive end of the pump (pulley end, hub end, shaft end), remove retaining ring, remove pin (17), remove woodruff key (18) and loosen setscrew if used. **Note:** If the pulley (23) or hub (24) is pressed on the shaft, it will be necessary to locate a support directly between the pump body and pulley or hub as close to the shaft as possible. Press the shaft out of the pulley or hub. Make sure the body is free and not supported.
- F. For the M71, GC1, GC4 and GC5, remove the two bolts that hold the aluminum adapter onto the bearing body. Pull the adapter off of the bearing body and press the lip seal out of the adapter.
- G. Remove the large internal retaining ring (16) from the body at the end of the bearing.
- H. Support the body, and press the shaft, bearings (19), spacer (20) and retaining rings (11) out through the bearing or pulley end of the body.
- I. The seal assembly (14) is pressed into the body. It can be removed by pushing a tool through the bearing end and up against the metal or back side of the seal. **Note:** On some pumps, there is a spacer located between the pulley (hub) and bearing on the shaft. On other pumps, the bearings are positioned on the shaft with a retaining ring on each end. Support the bearings on the inner race, and push the shaft out of the bearings.

### Assembly:

- A. When assembling the cam (21), put Permatex #1 on the backside of the cam and the screw (22) that retains the cam. Wipe off any Permatex that gets into the impeller cavity.
- B. Assemble a retaining ring (11) on the shaft into the second groove from the impeller end. Push the ball bearing (19) over the shaft (10). Press on the inner race of the bearing. Push the bearing up against the retaining ring. (Push the bearing on from the pulley or drive end, except for M71, GC1, GC4 and GC5 pumps). Assemble a spacer and then the second ball bearing. Assemble the second retaining ring over the shaft and up against the ball bearing, if required.
- C. There is a large internal retaining ring (16) located in the body that provides a shoulder for the bearings (approximately 1.38" from the bearing end of the body). If it has been removed, it must be inserted at this time.
- D. Press the mechanical seal (14) into the body from the impeller end. Make sure that seal is pressed in square. A tool should be used to assure proper assembly.

# 09959, 10615, and 15000 G Series Technical Guide *(continued)*

- E. Push the bearing and shaft assembly into the body using care not to cock the bearing. A tool is recommended that will give you uniform pressure on the bearing outer race. Lock the bearing in place with the large internal retaining ring.
- F. Assemble the seat assembly (13), shoulder washer (12) and retaining ring (11 or 15) over the shaft from the impeller end. Locate the white ceramic surface against the seal – Do not damage (scratch) the white ceramic surface of the seat, or the seal and seat assembly might leak. Lubricate the rubber part of the seat and use a tool for ease of assembly.
- G. For the M71, GC1, GC4 and GC5, press a new lip seal into the aluminum adapter (with the metal backing ring away from the engine). Replace the adapter onto the bearing body. Assemble the lockwashers and bolts to the adapter. Torque the bolts to 24 ft.-lbs.
- H. While supporting the shaft, press the pulley/gear (23) or hub (24) onto the shaft. Secure pulley/hub with pin (17) or key (18) and retaining ring or setscrew as needed.
- I. Press the woodruff key (9) into the shaft. Make sure the stainless steel key is used at this location.
- J. Assemble the impeller (5) into the housing (4). **Note:** Do not use petroleum-based fluid to lubricate the impeller.
- K. Place the o-ring (6) in the groove in the housing (4). A small dab of grease will help hold it in position until the housing to body screws are tightened. Assemble the gasket (8) and spacer plate (7) on the body (3), and line up the screw holes.
- L. Replace the lockwashers (2), and tighten the screws (1). Torque the screws to 84 in.-lbs
- M. After installation, inspect the pump seal, lip seal, body, housing and cam areas for leaks.

## 09959 Chart

Sherwood #		G15	G21	G30-2B	G30-2	G9901	G9903	J70	K75B
Engine Manufacturer		Chris Craft		Chris Craft	Chris Craft	Volvo/OMC	Volvo/OMC	Commander	
Engine Model		350		350	350	6&8 Cyl	4 Cyl	302&351	
Item	QTY			16.80-18346	16.80-18346	3852398	3855079	CM1-10-610	
1	Screw	3	12857	12857	12857	12857	12857	12857	12857
2	Lockwasher	3	12710	12710	12710	12710	21757	21757	12710
3	Body	1	12324	12328	19784	12328	21153	21759	12328
4	Housing	1	12303	12303	12303	12303	21151	21151	12303
5	Impeller	1	9959	9959	9959	9959	9959	9959	9959
6	O-ring	1	12231	12231	12231	12231	12231	12231	12231
7	End Plate	1	25150	25150	25150	25150	25150	25150	25150
8	Gasket	1	12855	12855	12855	12855	12855	12855	12855
9	Key	1	4432	4432	4432	4432	4432	4432	4432
10	Shaft	1	12233	13363	12612	12612	13363	13363	13274
11	Retaining Ring (Ext)	2/3	4258	4258	4258	4258	4258	4258	4258
12	Washer	1	4264	4264	4264	4264	4264	4264	4264
15	Retaining Ring (Ext)	1	12305						
16	Retaining Ring (Int)	2	4259	4259	4259	4259	4259	4259	4259
17	Pin	1			12791	12791			
18	Key	1	12622					12622	
19	Ball Bearing	2	23448	23448	23448	23448	23448	23448	23448
20	Spacer	1	5133	5133	5133	5133	5133	5133	5133
21	Cam	1	15883	15883	15883	15883	15883	15883	15883
22	Cam Screw	1	10515	10515	10515	10515	10515	10515	10515
23	Drive Pulley or Gear	1	12323	19729			21154	21175	13429
24	Hub	1			12615	12615			13795
13/14	Water Seal/Seat Assy	1	12859	12859	12859	12859	12859	12859	12859
	Minor Repair Kit		23979	23979	23979	23979	23979	23979	23979
	Major Repair Kit		12665	12665	12665	12665	12665	12665	12665



# 09959, 10615, and 15000 G Series Technical Guide

## 10615 Chart

Sherwood #		G5	G7	G7B	G45-1	G46	G50	G55-2	K90	L10B	M71
Engine Manufacturer		Chrys.	Chrys.	Chrys.	Chris Craft	OMC	Chrys.		Isuzu		
Engine Model		318, 340	318, 360	318, 360	454	V8 Chevy	318, 340		4,6 Cyl Diesel		
Item	QTY	3675763	4142878	4142878	16.80-18347	985096	3619212		X-26-230-1023		
1	Screw	3	12857	12857	12857	12857	12857	12857	12857	12857	12857
2	Lockwasher	3	12710	12710	12710	12710	12710	12710	12710	12710	12710
3	Body	1	12227	12227	19789	12328	12328	12227	12328	12227	19948
4	Housing	1	12228	12952	12952	12228	12952	12228	12907	12228	13899
5	Impeller	1	10615	10615	10615	10615	10615	10615	10615	10615	10615
6	O-ring	1	12231	12231	12231	12231	12231	12231	12231	12231	12231
7	End Plate	1	25150	25150	25150	25150	25150	25150	25150	25150	25150
8	Gasket	1	12855	12855	12855	12855	12855	12855	12855	12855	12855
9	Key	1	4432	4432	4432	4432	4432	4432	4432	4432	4432
10	Shaft	1	12233	13363	13363	12612	13363	12233	12596	12596	13363
11	Retaining Ring (Ext)	2/3	4258	4258	4258	4258	4258	4258	4258	4258	4258
12	Washer	1	4264	4264	4264	4264	4264	4264	4264	4264	4264
15	Retaining Ring (Ext)	1	12305					12305			
16	Retaining Ring (Int)	2	4259	4259	4259	4259	4259	4259	4259	4259	4259
17	Pin	1	11541			12791		11541	9420		
18	Key	1	12622					12622			
19	Ball Bearing	2	23448	23448	23448	23448	23448	23448	23448	23448	23448
20	Spacer	1	5133	5133	5133	5133	5133	5133	5133	5133	5133
21	Cam	1	10944	10929	10929	10944	10929	10944	10944	10944	10929
22	Cam Screw	1	10515	10515	10515	10515	10515	10515	10515	10515	10515
23	Drive Pulley or Gear	1	12326	15055	15055		15048	12323		14992	14184
24	Hub	1				12615			12926		13795
13/14	Water Seal/Seat Assy	1	12859	12859	12859	12859	12859	12859	12859	12859	12859
	Oil Seal	1									10514
	Minor Repair Kit		23976	23976	23976	23976	23976	23976	23976	23976	23976
	Major Repair Kit		23977	23977	23977	23977	23977	23977	23977	23977	23977

## 15000 Chart

Sherwood #		GC1	GC4	GC5	G151	G155	G157	G1503
Item	QTY							
1	Screw	3	12857	12857	12857	12857	12857	12857
2	Lockwasher	3	12710	12710	12710	12710	12710	
3	Body	1	14160	14160	19907	12227	12227	23231
4	Housing	1	17684	17684	17684	17684	19880	17684
5	Impeller	1	15000	15000	15000	15000	15000	15000
6	O-ring	1	12231	12231	12231	12231	12231	12231
7	End Plate	1	25150	25150	25150	25150	25150	25150
8	Gasket	1	12855	12855	12855	12855	12855	
9	Key	1	4432	4432	4432	4432	4432	4432
10	Shaft	1	21069	21069	19843	19570	19570	21231
11	Retaining Ring (Ext)	2/3	4258	4258	4258	4258	4258	4258
12	Washer	1	4264	4264	4264	4264	4264	4264
15	Retaining Ring (Ext)	1	14161	14161				
16	Retaining Ring (Int)	2	4259	4259	4259	4259	4259	4259
19	Ball Bearing	2	23448	23448	23448	23448	23448	23448
20	Spacer	1	5133	5133	19906	5133	5133	5133
21	Cam	1	18398	18398	18398	18314	18314	18314
22	Cam Screw	1	10515	10515	10515	10515	10515	
23	Drive Pulley or Gear	1	14184	14184	14184	15055	15055	
24	Hub	1					21232	
13/14	Water Seal/Seat Assy	1	12859	12859	12859	12859	12859	12859/12966
	Oil Seal	1	10514	10514	10514			12966
	Cover							21173
	Minor Repair Kit		23980	23980	23980	23980	23980	23980
	Major Repair Kit		23981	23981	23981	23981	23981	23256

# R Series Technical Guide

## Assembly/Disassembly Instructions

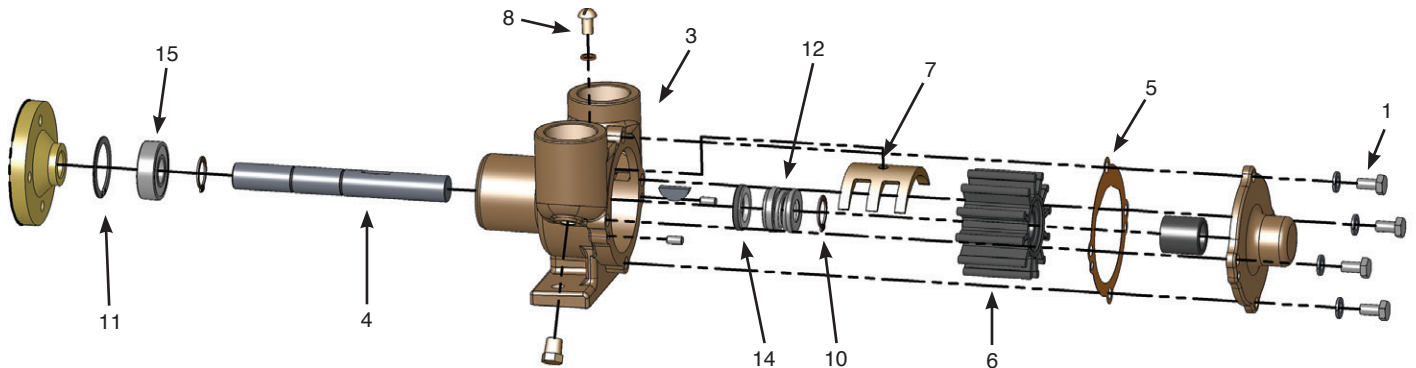

The following assembly/disassembly procedures apply to all R Series pumps. Deviations from pump to pump are primarily a result of different methods of drive and mounting. Pump numbers can be found on the tag or stamped on the pedestal base of the pump.

### Disassembly:

- A. Remove the screws (1) and lockwashers that hold the cover to the body (3). Pull the cover and bushing assembly (2) off the drive shaft (4).
- B. Remove the vellum gasket (5). Sherwood recommends replacing the gasket each time the pump is assembled, however, if you plan to use the same gasket, it should be submerged in water until pump is reassembled. If gasket dries, it will shrink.
- C. The impeller (6) can now be removed by using pliers and grasping a vane on one side, then the other, alternating positions and gently pulling. Make sure you have a good grip on each vane so the pliers will not slip and damage the impeller.
- D. The cam (7) can be removed by removing the screw (8) that goes down through the top of the body between the intake and discharge ports.
- E. Remove the two screws (18) and lockwashers from the bearing housing (9) on the drive shaft end of the housing. This will allow you to remove the bearing housing, seal assembly, and shaft from the body.
- F. Remove the woodruff key from the shaft. If the shaft is to be used again and if it is put in a vise, always use lead over the jaws of the vise so that the shaft is not damaged.
- G. Remove the retaining ring (10) from the shaft at the seal end. The seal (12) can now be removed from the shaft. Note how the seal and seat assembly (14) are arranged so they can be properly reassembled.
- H. For the E35, support the hub and press the shaft and housing assembly off of the hub.
- I. By removing the large internal retaining ring (11) from the bearing housing, the bearing (15) and shaft can be pressed out of the bearing housing. Support the bearing housing, and press on the shaft from the impeller end.
- J. Pumps designed without separate bearing housings may require shaft removal from opposite end depending on housing design.
- K. The seat assembly (13) is pressed into the bearing housing and can be removed by pushing a tool through the bearing end and against the rubber or backside of the seat.

### Assembly:

- A. When replacing the carbon bushing (16) in the cover, care should be taken not to crack the bushing. A tool that pilots on the inside diameter and presses uniformly against the end of the bushing is recommended.
- B. When assembling the cam (7), put Permatex #1 on back side of cam and the screw (8) that retains the cam. Wipe off any Permatex that gets into the impeller cavity.
- C. Assemble a retaining ring (10) on the shaft into the second groove from the drive shaft end. Push the ball bearing (15) over the shaft (4). Press on the inner race of the bearing. Push the bearing up against the retaining ring. Assemble the second snap ring (10) over the shaft and up against the ball bearing, from the flat shaft end.
- D. Push the bearing and shaft assembly into the bearing housing (9) using care not to cock the bearing. A tool is recommended that will give you uniform pressure on the bearing outer race. Lock the bearing in place with the large internal retaining ring.
- E. For pumps without a bearing housing, assemble the seat (13) into the counter bore in the housing (3) with the ceramic facing the impeller. Push the shaft and bearing assembly into the housing. Lock the bearings in place with retaining ring (11). While supporting the shaft, press the hub onto the shaft.

# R Series Technical Guide

## Assembly/Disassembly Instructions

- F. From the opposite end (woodruff key end of the shaft), assemble the seat (13) over the shaft, rubber side first. Push it into the counter bore in the bearing housing. Do not damage (scratch) the white ceramic surface on the seat, or the seal and seat assembly might leak.
- G. Push the seal assembly (12) over the shaft and down against the seat. Do not damage the black carbon washer that rides against the ceramic.
- H. Assemble the third retaining ring (10) on the shaft. It will be necessary to compress the seal assembly to allow the retaining ring to enter the groove on the shaft.
- I. Press the woodruff key into the keyway in the shaft.
- J. Assemble the small gasket (17) over the pilot on the bearing housing and assemble the complete shaft, bearing, and seal assembly to the body. Use the two long screws (18) for fastening the bearing housing to the body. Torque the screws to 50 in.-lbs. for the R30G and R30G-1 or 84 in.-lbs. for the R10870G and R50G.
- K. Assemble the impeller (6) over the shaft (4). Line up the key in the shaft with the keyway in the impeller, and push the impeller into the body (3).
- L. Push the gasket (5) and cover (2) over the dowel pins, and attach the cover with the screws (1) and lockwashers. Torque the screws (1) to 50 in.-lbs. for the R30G and R30G-1 or 84 in.-lbs. for the R10870G, R50G, R102 and E35.
- M. After installation, inspect the pump seal, body, housing and cam areas for leaks.

		<b>Sherwood #</b>	<b>R30G</b>	<b>R30G-1</b>	<b>R10870G</b>	<b>R50G</b>	<b>R102</b>	<b>E35</b>
		Port Size (NPT)	1/2"	1/2"	3/4"	3/4"	1"	1"
		Shaft Drive Description	Flat	Keyed	Keyed	Flat	Keyed	Pulley Hub
<b>Item</b>	<b>QTY</b>							
1	Screw	4/6	12686	18999	01482	01482	01483	01483
2	Cover Assy	1	10281	10281	10096	10096	10183	10183
3	Body Assy	1	10597	10597	10177	10177	18503	11246
4	Shaft	1	10289	11854	10852	10175	18502	11744
5	Gasket, Cover	1	10286	10286	10103	10103	10931	10931
6	Impeller	1	10077	10077	09959	09959	10615	10615
7	Cam	1	10285	10285	10072	10072	10929	10929
8	Cam Screw	1	10195	10195	09919	09919	10515	10515
9	Bearing/Housing Assy	1	10198	10198	10172	10172		
10	Retaining Ring (Ext)	3	04304	04304	04258	04258	04258	04258
11	Retaining Ring (Int)	1	04303	04303	04259	04259	04259	04259
12	Seal	1	10522	10522	18743	18743	18743	18743
13	Seat	1	11361	11361	10926	10926	10926	10926
14	Seal/Seat Assy	1	11367	11367	10927	10927	10927	10927
15	Ball Bearing	1	04306	04306	04257	04257	04257	04257
16	Bushing	1	02075	02075	06333	06333	06333	06333
17	Gasket, Housing	1	10197	10197	10171	10171		
18	Screws	2	05437	05437	04265	04265		
	Key	1	10093	10093	04432	04432	04432	04432
	Dowel Pin	2	01311	01311	01311	01311	01311	01311
	Plug	1/2	00336	00336	00336	00336	00336	00336
	Hub	1						97176
	Minor Repair Kit		10996	10996	10997	10997	10999	10999
	Major Repair Kit		24025	24025	12937	12937	11068	11068

# P Series Technical Guide – 10615 Impeller

## Assembly/Disassembly Instructions

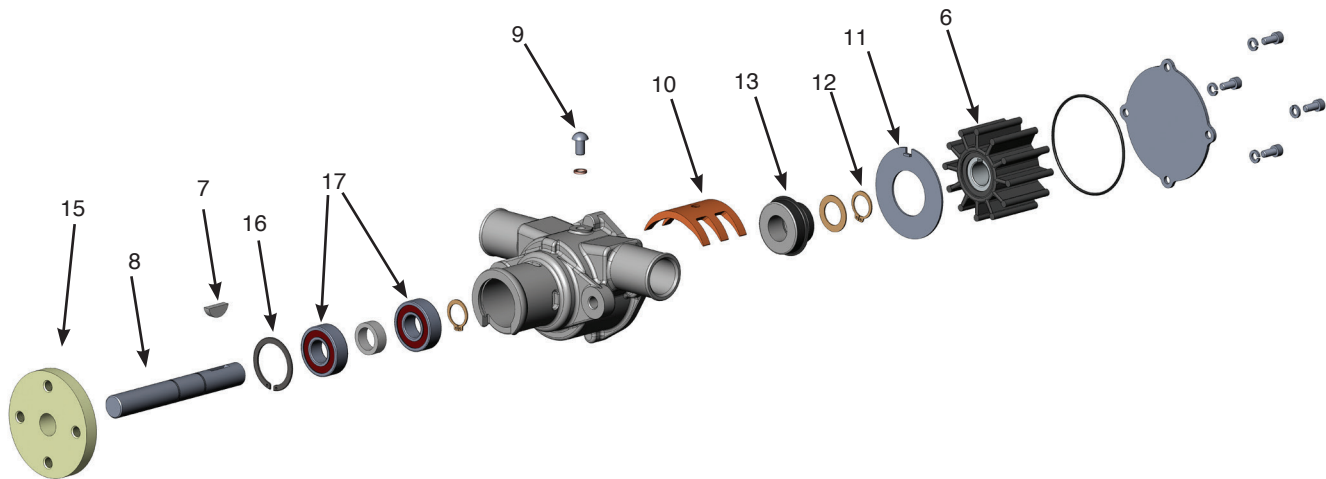

The following assembly/disassembly procedures apply to many P Series pumps. Deviations from pump to pump are primarily a result of different methods of drive and mounting.

### Disassembly:

- A. Remove the screws (1) and lockwashers (2) that hold the cover (3) to the housing (4).
- B. Remove the o-ring or gasket (5) from the housing.
- C. Using two pliers or an impeller puller, remove the impeller (6) from the housing. Knock the key (7) out of the shaft (8).
- D. Remove the cam screw and washer (9) from the cam (10) and pull the cam out of the housing. The wear plate (11) can now be removed from the housing.
- E. Using an external snap ring pliers, remove the retaining ring (12) that holds the seal seat in place. Slide the seal seat (13) and washer (14) off the shaft.
- F. From the drive end of the pump (pulley end or hub end) locate a support directly between the pump housing and hub (15) as close to the shaft as possible. Make sure the housing is free and not supported, and then press the shaft out of the hub.
- G. Remove the large internal retaining ring (16) from the housing at the end of the bearing.
- H. Support the housing and press the shaft, bearings (17), spacer (18), slinger (19), and retaining ring (12) out through the pulley end or hub end of the housing.
- I. The seal assembly (13) is pressed into the body. It can be removed by pushing a tool through the bearing end and up against the metal or back side of the seal.
- J. Remove the retaining ring from the shaft and bearing assembly. Support the bearings on the inner race and push the shaft out of the bearings.

### Assembly:

- A. Assemble a retaining ring (12) on the shaft into the second groove from the impeller end. Push the first ball bearing (17) from the pulley or drive end of the pump over the shaft (8) and against the retaining ring by pressing on the inner race of the bearing. Assemble the spacer (18), and then push the second ball bearing on the shaft and against the spacer in the same manner the first bearing was pressed on the shaft. Slide the slinger (19) against the retaining ring (it should be positioned between the bearings and mechanical seal).
- B. Press the mechanical seal (13) into the body from the impeller end. Make sure the seal is pressed in square and that the carbon face is not scratched during assembly. A tool should be used to assure proper assembly. The carbon face is positioned toward the impeller.
- C. Push the bearing and shaft assembly into the housing (4) using care not to cock the bearing. A tool is recommended that will give you uniform pressure on the bearing outer race. Lock the bearing in place with the large internal retaining ring (16).
- D. Assemble the ceramic seat assembly (13), washer (14) and retaining ring (12) over the shaft from the impeller end. Locate the white ceramic surface against the carbon face of the seal. Warning: Do not damage (scratch) the white ceramic surface of the seat or the carbon face of the seal – minor scratches can cause the seat assembly to leak. Lubricate the rubber part of the seat with a non-petroleum fluid for ease of assembly.
- E. Support the shaft at the impeller end without contacting the mechanical seal. Press the hub (15) onto the shaft flush to the

## P Series Technical Guide – 10615 Impeller

### Assembly/Disassembly Instructions

ball bearings. Failure to support the shaft or placing pressure against the mechanical seal during this step will cause seal and/or bearing damage.

- F. Place the wear plate (11) in the housing. Put Permatex #1 on the backside of the cam (10) and the screw (9) that retains the cam. Wipe off any Permatex that gets into the impeller cavity. Assemble the cam by placing it into the housing and securing it with the cam screw and washer assembly. Press the woodruff key (9) into the shaft.
- G. Assemble the impeller (5) into the housing. **Note:** Do not use petroleum-based fluid to lubricate the impeller.
- H. Assemble the gasket or o-ring (5) and cover (3) on the housing. Replace the lockwashers (2) and screws (1) on the cover and torque the screws to 30-42 in-lbs on the P1016 and 50-60 in-lbs for all other pumps.
- I. After installation inspect the pump seal, housing, cam area, and cover for leaks.

	Sherwood #		P101	P1012	P1014	P1015	P1016
Item		QTY					
1	Cap Screw	4	21381	23966	23966	23966	24888
2	Lockwasher	4	00343	00343	00343	00343	24889
3	Cover Plate	1	19291	23946	21120	23912	24887
4	Housing	1	19294	19294	24107	24107	24882
5	O-Ring/Gasket	1	19251	19251	12231	12231	12231
6	Impeller	1	10615	10615	10615	10615	10615
7	Key	1	04432	04432	04432	04432	04432
8	Shaft	1	19293	19293	19293	19293	24885
9	Cam Screw Assy.	1	10515C	10515C	10515C	10515C	24884/19996
10	Cam	1	10944	10944	10944	10944	10929
11	Wear Plate	1	19295	19295	19295	19295	19295
12	Retaining Ring	2	04258	04258	04258	04258	04258
13	Water Seal/Seat Assy.	1	12859	12859	12859	12859	12859
14	Washer	1	04264	04264	04264	04264	04264
15	Hub	1	97176	97176	97176	97176	24883
16	Retaining Ring	1	04259	04259	04259	04259	04259
17	Bearing	2	12211	12211	12211	12211	12211
18	Spacer	1	05133	05133	05133	05133	24886
	Minor Repair Kit		19301	19301	23976	23976	23976
	Major Repair Kit		25029	25029	25029	25029	25009



# 17000 Series Technical Guide

## Assembly/Disassembly Instructions

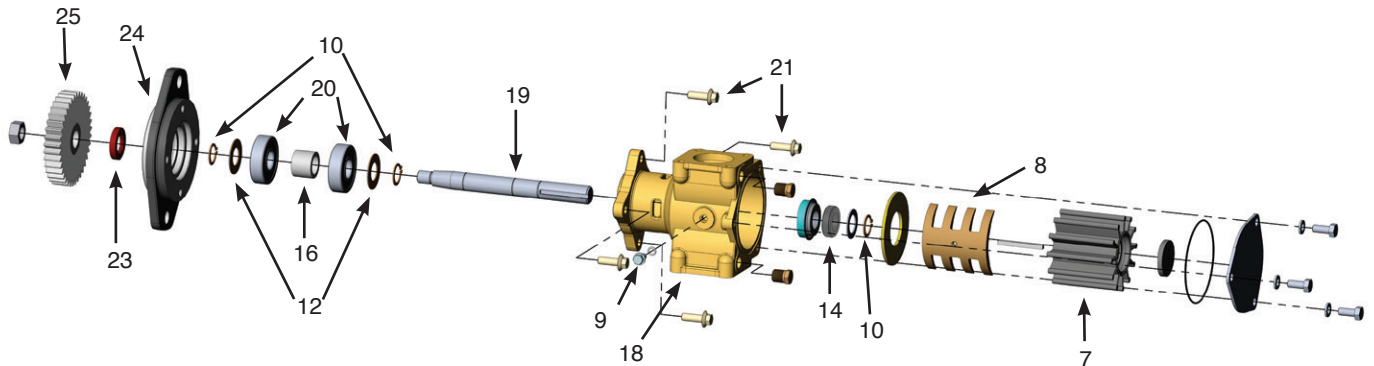

The following assembly/disassembly procedures apply to all 17000 Series pumps. Deviations from pump to pump are primarily a result of different methods of drive and mounting. Pump model numbers can be found stamped into the cover plate of the pump.

### Disassembly:

- A. Remove the three bolts (1) and lock washers (2) from the pump cover (3). The cover and o-ring (4) are now free. The impeller end cap (5) can be pried off with a screwdriver. Normally, impellers (7) can be removed by using the 23631 or 25105 impeller puller (3/4" – 16 bolt) for the 17000 threaded impeller or by using two pair of pliers to grip two of the impeller's vanes on opposite sides of the impeller. A penetrating lubricant will help loosen a stuck impeller. Also, rotating the shaft by hand may help free the impeller. The 3/16" key (6) will also be removed at this time.
- B. Remove any pulleys or drive gears (25) from the drive shaft. For tapered shaft models (all models except P173 and P1719), it is necessary to remove the shaft nut and pull the gear or pulley with a puller. For models with pressed on gears (P173), two threaded holes are provided in the gear. An appropriate puller may be attached to these two holes to remove the gear from the shaft.
- C. Most models will be equipped with a flange adapter (24). The flange adapter is held to the pump body by two socket head cap screws (21), either 3/8" or 10mm, depending on the model. The screws are removed by using a hex socket wrench. More current models are mounted with four 8mm flange hex head bolts. The adapter is then removed. If the lip seal (23) in the adapter requires replacing, it can be pressed out at this time.
- D. The cam (8) and cam screw (9) are removed. The internal wear plate (13) will drop out. The retaining ring (10), washer (11) and seal seat (14) are then removed. Pump models P1710C, P1716C, P1722C, P1727C, P1730C, P1732C, and P17XX-04 do not utilize this retaining ring and washer. For these pumps, the seal seat can be removed in step F below.
- E. From the ball bearing end, the internal snap ring (17) must be removed on models P171 through P176, P1710 and P1732. All other models have extended bearing assemblies and are held together by means of the flanged adapter.
- F. The shaft/bearing assembly (19) is pressed out of the body from the impeller end of the housing and removed from the engine end of the pump. For pump models P1710C, P1716C, P1722C, P1727C, P1730C, P1732C, and P17XX-04, the seal seat will press off of the shaft when the shaft is forced out of the pump.
- G. On earlier models, the two external snap rings (10) are removed from the shaft (19) along with the bearing washers (12), permitting removal of bearings (20). More recent designs do not utilize the bearing washers, and they have one retaining ring in-between the ball bearings. The mechanical seal (15) may now be removed by pressing it out from the bearing side of the housing (18).

**Warning:** If a shaft/bearing assembly exists for the particular model that is being repaired, do not try to build the shaft/bearing assembly from the individual parts, but instead purchase the entire assembly. Due to extremely tight tolerances, special assembly procedures for this assembly must be followed to prevent galling and subsequent leakage in the oil seal area of the pump.

### Reassembly:

- A. Press mechanical seal (15) into housing (18), using the seal pusher provided in the 25115 seal kit if applicable, with the grey silicon carbide or black carbon seal face toward the impeller.
- B. On all older model pumps with mounting adapters, the lip seal (23) will have to be replaced prior to replacing the flange adapter (24). Care should be taken to ensure proper alignment of the lip seal to the adapter and that the lip seal is uniformly pressed to prevent distortion. The metal backing ring of the lip seal goes toward the pump and away from the engine.
- C. Skip this step if the entire shaft/bearing assembly is available for the particular model that is being repaired. Install external snap ring (10) on shaft (19). Next, place washer (12), bearing (20), bearing spacer (16), second bearing (20) and washer (12) and secure with the second external snap ring (10). The bearings will have to be pressed on from the pulley/gear end. Note that it is extremely important to properly align the bearings to the shaft prior to the press, otherwise the possibility exists of galling the shaft in the area of the lip seal.

## 17000 Series Technical Guide

**Warning:** The new 25119 and 25120 shaft and bearing assemblies can only be used with the 25115 mechanical seal kit which utilizes a pressed on seal seat. This seal is an upgrade over the standard mechanical seal. Attempting to use the 15955 or 23799 mechanical seal with the 25119 or 25120 shaft bearing assembly or in a standard P1700 pump will damage the seal and cause a shaft leak. The 25115 mechanical seal kit CANNOT be used on the standard P1700 shaft due to the design. The 25115 mechanical seal kit can only be used in either a P1710C, P1716C, P1722C, P1727C, P1730C, P1732C, or P17XX-04 pump or with a P1700 series pump that has been upgraded with the 25119 or 25120 shaft and bearing assembly. Attempting to use the 25115 mechanical seal on an older shaft design will damage the shaft and mechanical seal which will cause a seal leak.

**Note:** The 25119 and 25120 shaft and bearing assemblies can be identified by the indentation machined into the shaft on the impeller end, the slightly undercut shaft in the key area which allows the seal seat to slide down the shaft to within 3/8" of the mechanical seal on the 25120, or the use of a plunged key on the 25119, or the lack of a snap ring groove between the impeller and the bearing closest to the impeller. These features are all absent on older shaft bearing versions of the shaft.

- D. Press the bearing and shaft assembly into the housing (18). In applicable pump models, replace the internal snap ring (17). The use of Loctite #262 or equivalent is recommended on the adapter bolts. The adapter (24) may be reassembled to the pump housing (18) at this time with two or four bolts (21) as applicable. Torque the adapter bolts to 18 ft-lbs.
- E. The seal seat (14) is now installed from the impeller end of the housing. The grey silicon carbide or white ceramic seat should be placed against the grey silicon carbide or black carbon seal face of the mechanical seal (15). **Caution:** Care must be taken to remove all burrs, salt buildup, and other corrosion from the keyway and seal seat area to prevent cutting the rubber cup or galling the 25115 metal seal sleeve.
1. When installing the 25115 seat with the metal sleeve (see the Warning and Note above), use the seal installation tool provided in the mechanical seal, minor and major kits, to press the seal seat (14) to the correct position on the shaft. Place the seal seat in the seal installation tool with the grey silicon carbide face away from the tool and the metal backing cup inside the tool. Slide the seal seat and tool over the shaft from the impeller end of the pump. The seal seat is pressed onto the shaft until the seal installation tool contacts the metal edge of the mechanical seal case. This metal to plastic contact between the seal edge and the plastic seal installation tool ensures the proper seal compression. The press holds the seat in place; no snap ring is used in this design.
  2. When installing the ceramic and rubber boot, a pusher should be used with a diameter only slightly greater than the shaft diameter (.80"). Soapy water or a lubricant from a seal manufacturer may be used in assembly. Oil or grease must not be used as it will prevent the rubber cup from properly gripping the shaft. The seat and cup are pressed just beyond the external/snap ring groove. The seat should be inspected to ensure that the cup did not become partially dislodged during the press procedure. The washer (11) and external snap ring (10) are then installed.
- F. The internal wear plate (13) is dropped in place, anti-rotation pin aligned with the cast slot in the bottom of the housing. The cam (8) is reinstalled and secured with the cam screw (9) and cam screw o-ring. Older model cam screws were sealed by means of a nylon washer requiring Permatex or other sealant to seal the cam screw. The cam screw should be inspected to ensure that it does not protrude below the cam. This condition is possible if the nylon seal is badly deformed or if a substitute screw is used. Should the screw protrude beneath the cam, replace it with a new screw, or grind flush. Failure to do so will result in immediate impeller damage.
- G. At this time, if applicable, press on any gears (25), pulleys, or hubs onto the shaft. While pressing on the drive mechanism, the shaft (19) must be securely supported from the impeller end and in line with the press. Failure to do so will result in either damaged bearings and/or a canted gear with excessive run out. For the base model pumps P1716, P1722, P1727, P1730 and P1731, replace the tapered gear and gear nut on the shaft. Use Loctite #262 on the gear threads and torque the nut to 50 ft-lbs. For all other tapered gear and shaft assemblies, see the applicable engine manufacturers' requirements for thread sealant and torque specifications.
- H. Install the plunged key into the shaft for pumps P1710C, P1732C, and equivalent P17XX-04 designs without the thru-key.  
**Note:** The 1-1/2" key in the 17000K impeller kit is the plunged key.
- I. Install the impeller (7) using a non-petroleum based lubricant such as silicon or soapy water. **Note:** Do not use petroleum-based fluids as they will damage the impeller. The impeller is installed using a twisting motion. Ensure the impeller blades are bent in the same direction as upon removal. Once installed, rotate the shaft to align keyway and slide the key (6) in place (not applicable for the plunged key designs P1710C, P1732C, and equivalent P17XX-04). **Note:** The 2" key found in the 17000K is used in all models other than the designs P1710C, P1732C, and equivalent P17XX-04. Cover the key hole in the impeller insert with the rubber end plug (5). **Caution:** Failure to place the plug in place on the 17000A impeller will cause the key to walk out of the shaft keyway and damage the cover. The 17000 impeller requires that the key be placed on the shaft prior to installation.
- J. Replace the cover o-ring (4), cover (3), lock washers (2), and the cover cap screws (1). Torque the cap screws to 14 ft-lbs.  
**Note:** If the cover is replaced with a new one, record the information on the original cover to help identify the pump for future repairs and maintenance.
- K. After installation, inspect the pump seal, lip seal, body, housing, and cam areas for leaks.

# 17000 Series Technical Guide

Sherwood #			P176X	P1710A	P1710C	P1716A	P1716C	P1719X	P1722A	P1722C	P1726X
			P176	P1710	P1710-04	P1716B-01	P1716-04	P1719	P1722B-01	P1722-04	P1726
			P176-02	P1710-02		P1716B-02		P1719-01	P1722B-02		
				P1710X		P1716X		P1719F-01	P1722X		
Item		QTY									
1	Cap Screw	3	16029	19626	19626	19626	19626	19626	19626	19626	19626
2	Lockwasher	3	15944	15944	15944	15944	15944	15944	15944	15944	15944
3	Cover Plate	1	18742	18742	18742	18742	18742	18742	18742	18742	18742
4	O-ring	1	15945	15945	15945	15945	15945	15945	15945	15945	15945
5	Impeller Cap	1	24626	24626	24626	24626	24626	24626	24626	24626	24626
6	Key	1	19667	19667	25152	19667	19667	19667	19667	19667	19667
7	Impeller	1	17000	17000	17000	17000	17000	17000	17000	17000	17000
8	Cam	1	18271	18271	18271	18271	18271	18271	18271	18271	18271
9	Cam Screw	1	10515	19714	19714	19714	19714	19714	19714	19714	19714
10	Retaining Ring (Ext)	1/2/3	15952	15952		15952		15952	15952		15952
11	Washer	1	15959	15959		15959		15959	15959		15959
12	Washer	2	19614					19614			
13	Wear Plate-Pin Assy	1	18441	24162	24162	18441	24162	24162	18441	24162	24162
14/15	Water Seal/Seat Assy	1	15955	15955	25115	15955	25115	15955	15955	25115	15955
16	Spacer	1	15940					19615			
17	Retaining Ring (Int)	1	15942	15942	15942						15942
18	Housing	1	19015	24161	24161	19630	19630	24409	19630	19630	24161
19	Shaft	1	19620					19345			
19	Shaft/Bearing Assy	1		25119*	25119	25120*	25120		25120	25120	25119*
20	Ball Bearing	2	15951					15951			
21	Adaptor Bolts	4		19708	19708	19708	19708	19708	19708	19708	19708
23	Oil Lip Seal	1		21776	21776	24250	24250	24250	24250	24250	21776
24	Adaptor	1		19699	19699	19727	19727	19700	19955	19955	19699
	Gear Assy/Hub	1				22495	22495		22495	22495	
	Cam Screw O-ring	1		19712	19712	19712	19712	19712	19712	19712	19712
	Gear Nut	1				19730	19730		19730	19730	
	Adaptor Gasket	1				21570	21570		21570	21570	
	Flanged Port O-rings	2									
	Flanged Port Bolts	8									
	Slinger	1		24156	24156	24156	24156		24156	24156	24156
	Minor Repair Kit		23973	23973	25123	23972**	25124	23972	23972**	25124	23973
	Major Repair Kit		23975	25121	25121	25122**	25122	23974	25122**	25122	25121

Sherwood #			P1727A	P1727C	P1730A	P1730C	P1731	P1731-04	P1732A	P1732C	P1733X
			P1727FB	P1727-04	P1730-01	P1730-04	P1731-01		P1732-01	P1732-04	P1733F-01
			P1727FB-01		P1730-02	P1730F-04	P1731F-02		P1732-02		
			P1727FB-02		P1730F-01				P1732X		
			P1727X		P1730F-02						
					P1730X						
Item		QTY									
1	Cap Screw	3	19626	19626	19626	19626	19626	19626	19626	19626	19626
2	Lockwasher	3	15944	15944	15944	15944	15944	15944	15944	15944	15944
3	Cover Plate	1	18742	18742	18742	18742	18742	18742	18742	18742	18742
4	O-ring	1	15945	15945	15945	15945	15945	15945	15945	15945	15945
5	Impeller Cap	1	24626	24626	24626	24626	24626	24626	24626	24626	24626
6	Key	1	19667	19667	19667	19667	19667	19667	19667	25152	19667
7	Impeller	1	17000	17000	17000	17000	17000	17000	17000	17000	17000
8	Cam	1	18271	18271	18271	18271	18271	18271	21318	21318	18271
9	Cam Screw	1	19714	19714	19714	19714	19714	19714	19714	19714	19714
10	Retaining Ring (Ext)	1/2/3	15952		15952		15952		15952		15952
11	Washer	1	15959		15959		15959		15959		15959
12	Washer	2									19614
13	Wear Plate-Pin Assy	1	24162	24162	24162	24162	24162	24162	24162	24162	24162
14/15	Water Seal/Seat Assy	1	15955	25115	15955	25115	15955	25115	15955	25115	15955
16	Spacer	1									24014
17	Retaining Ring (Int)	1							15942	15942	
18	Housing	1	24176	24176	24176	24176	24176	24176	24161	24161	24409
19	Shaft	1									24015
19	Shaft/Bearing Assy	1	25120*	25120	25120*	25120	25120*	25120	25119*	25119	
20	Ball Bearing	2									15951
21	Adaptor Bolts	4	19708	19708	19708	19708	19708	19708	19708	19708	19708
23	Oil Lip Seal	1	24250	24250	24250	24250	24250	24250	21776	21776	24017
24	Adaptor	1	21205	21205	21985	21985	21985	21985	19699	19699	24016
	Gear Assy/Hub	1	22495	22495	22495	22495					
	Cam Screw O-ring	1	19712	19712	19712	19712	19712	19712	19712	19712	
	Gear Nut	1	19730	19730	19730	19730	19730	19730			
	Adaptor Gasket	1	21570	21570	21570	21570					
	Flanged Port O-rings	2	21525	21525	21525	21525	21525	21525			21525
	Flanged Port Bolts	8			21484	21484	21484	21484			
	Slinger	1	24156	24156	24156	24156	24156	24156	24156	24156	
	Minor Repair Kit		23972	25124	23972	25124	23972	25124	23973	25123	23972
	Major Repair Kit		25122	25122	25122	25122	25122	25122	25121	25121	25038

\* The 25115 seal kit must be used with the 25119, 25120, and 25100 shaft bearing upgrade. The change converts the pumps to a P17xxC or P2708X and the 15955 or 23799 seals will not work with these upgraded shaft/bearing assemblies.

\*\* Kit fitted with the 24162 wearplate. In some instances, the 24162 wearplate will not fit in the P1716 and P1722 pumps; the pin hole may be too shallow and the wearplate does not lay flat against the bottom of the housing bore. In these instances, use the 18441 wearplate with the smaller pin.

# 27000 Series Technical Guide

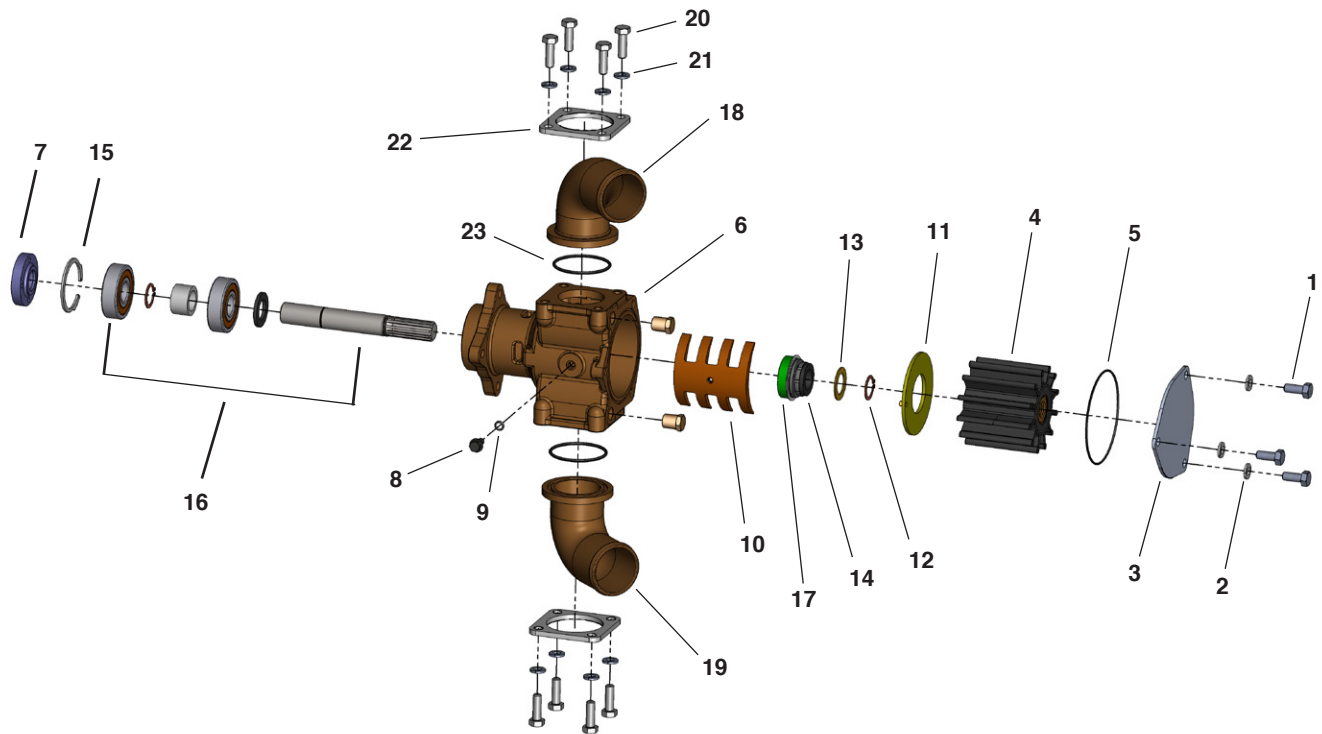

Result of different methods of drive and mounting. Pump model numbers can be found stamped into the cover plate of the pump.

## Disassembly:

- A. Remove the three bolts (1) and lockwashers (2) from the pump cover (3). Note the direction of the impeller blades upon removal. Remove the impeller (4) using the appropriate 24412 or 25106 M16 x 1.5 impeller puller. Remove the o-ring (5) from the housing (6).
- B. Remove the pulley hub (7) from the shaft using a bearing puller.
- C. Remove the cam screw (8), cam screw o-ring (9), and cam (10). The internal wear plate (11) will drop out. For the P2701-P2706 models, the retaining ring (12), washer (13) and seal seat (14) can then be removed.
- D. From the ball bearing end, the internal snap ring (15) must be removed. The shaft bearing assembly (16) is pressed out of the body from the impeller end of the housing. For pump models P2708-P2710, the mechanical seal seat (14) is now loose inside of the housing and can be removed. The mechanical seal (17) may now be pressed from the bearing side of the housing (6).
- E. Removal of the port adapters (18/19) is not necessary under normal conditions. If needed, first note the angle of each port to be able to reassemble to the correct orientation. Remove the bolts (20) and lockwashers (21) from the port adapter bracket (22). Remove and inspect the o-rings (23) for damage.
- F. Inspect the shaft for heavy fretting of the spline portion that drives the impeller. Inspect the bearings for loss of grease, corrosion, and rough rotation. If the shaft or bearings exhibit such wear, replace the entire shaft and bearing assembly (16) listed below.

**Warning:** The new water seal kit 25115-SHW is designed to be used with newer pump designs (P2708-01, P2708X, P2709-01, and P2710-01) or upgraded older pump designs using the new 25100-SHW shaft/bearing assembly that facilitates the new metal sleeve water seal. The 25115-SHW metal sleeve water seal cannot be used with the previous shaft and bearing assemblies. Doing so will cause damage to the shaft and the seal.

## Identifying the proper shaft for use with the 25115-SHW mechanical seal kit:

25100-SHW shaft/bearing assemblies do NOT have a retaining ring groove on the shaft in the area between the impeller and the first bearing (the bearing on the impeller end of the pump). These shaft and bearing assemblies can be used with the 25115-SHW. If a retaining ring exists between the impeller and the first bearing, do not use the 25115-SHW mechanical seal kit.

## 27000 Series Technical Guide *(continued)*

### Reassembly:

- A. Press mechanical seal (17) into housing (6) with the grey silicon carbide face of the mechanical seal toward the impeller cavity.
- B. Press the bearing and shaft assembly (16) into the housing (6) from the pulley end of the pump. Replace the internal snap ring (15).

**Warning:** The new water seal kit 25115-SHW is designed to be used with newer pump designs P2708-01, P2708X, P2709-01, and P2710-01) or upgraded older pump designs using the new 25100-SHW shaft/bearing assembly that facilitates the new metal sleeve water seal. The 25115-SHW metal sleeve water seal cannot be used with the previous shaft and bearing assemblies. Doing so will cause damage to the shaft and the seal.

### Identifying the proper shaft for use with the 25115-SHW mechanical seal kit:

25100-SHW shaft/bearing assemblies do NOT have a retaining ring groove on the shaft in the area between the impeller and the first bearing (the bearing on the impeller end of the pump). These shaft and bearing assemblies can be used with the 25115-SHW. If a retaining ring exists between the impeller and the first bearing, do not use the 25115-SHW mechanical seal kit.

- C. For Models P2701-P2706, the grey silicon carbide seat and rubber cup (14) is now installed from the impeller end of the housing with the grey face of the seal seat contacting the grey mechanical seal (17) face. In pressing the seal seat, a pusher should be used with a diameter only slightly greater than the shaft diameter (.80"). Soapy water or a lubricant from a seal manufacturer may be used in assembly. Oil or grease must not be used as it will prevent the rubber cup from properly gripping the shaft. The seat and cup are pressed just beyond the external/snap ring groove. The seat should be inspected to ensure that the cup did not become partially dislodged during the press procedure. The washer (13) and external snap ring (12) are then installed.
- D. For Models P2708-P2710, use the seal installation tool provided in the mechanical seal, minor and major kits, to press the seal seat (14) to the correct position on the shaft. Place the seal seat in the seal installation tool with the grey silicon carbide face away from the tool and the metal backing cup inside the tool. Slide the seal seat and tool over the shaft from the impeller end of the pump. The seal seat is pressed onto the shaft until the seal installation tool contacts the metal edge of the mechanical seal case. This metal to plastic contact between the seal edge and the plastic seal installation tool ensures the proper seal compression. Because the seal seat is pressed onto the shaft, there is no need for a snap ring to hold the seal seat in place.
- E. The internal wear plate (11) is dropped in place with the anti-rotation pin aligned with the cast slot in the bottom of the housing. Replace the cam screw o-ring (9) on the cam screw (8), then the cam (10) can be reinstalled and secured with the cam screw. The cam screw should be inspected to ensure that it does not protrude below the cam. Should the screw protrude beneath the cam, replace it with a new screw, or grind flush. Failure to do so will result in immediate impeller damage.
- F. At this time, press on the pulley hub (7). The shaft bearing assembly (16) must be securely supported from the impeller end and in line with the press. Failure to do so will result in either damaged bearings and/or a canted pulley hub with excessive run out.
- G. Install the impeller (4) using a non-petroleum based lubricant such as silicone or soapy water. **Note:** Do not use petroleum-based fluids as they will damage the impeller. The impeller is installed using a twisting motion. Ensure the impeller blades are bent in the same direction as upon removal.
- H. Replace the o-ring (5), cover (3), lockwashers (2), and three bolts (1). Torque the cap screws to 14 ft-lbs. **Note:** If the cover is replaced with a new one, record the information on the original cover to help identify the pump for future repairs and maintenance.
- I. If necessary, place the o-ring (23) in the port adapters (18/19). Slide the port adapter bracket (22) onto the ports, then replace the lockwashers (21) and bolts (20) to secure the ports to the housing. Be sure to align the ports as they were prior to removal.
- J. After installation, inspect the pump seal, lip seal, body, housing, and cam areas for leaks.



# 27000 Series Technical Guide

Sherwood #		P2701-01	P2701X	P2703-01	P2708-01	P2708X	P2709-01	
		P2704-01	P2702-01	P2705-01		P2710-01		
			P2706-01					
Item	QTY							
1	Cap Screw	3	19626-SHW	19626-SHW	19626-SHW	19626-SHW	19626-SHW	19626-SHW
2	Lockwasher	3	15944-SHW	15944-SHW	15944-SHW	15944-SHW	15944-SHW	15944-SHW
3	Cover Plate	1	18742-SHW	18742-SHW	18742-SHW	18742-SHW	18742-SHW	18742-SHW
4	Impeller	1	27000-SHW	27000-SHW	27000-SHW	27000-SHW	27000-SHW	27000-SHW
5	O-ring	1	15945-SHW	15945-SHW	15945-SHW	15945-SHW	15945-SHW	15945-SHW
6	Housing	1	24161-SHW	24161-SHW	24161-SHW	24161-SHW	24161-SHW	24161-SHW
7	Gear Assy/Hub	1	24879-SHW	24879-SHW	24879-SHW	24879-SHW	24879-SHW	24879-SHW
8	Cam Screw	1	19714-SHW	19714-SHW	19714-SHW	19714-SHW	19714-SHW	19714-SHW
9	Cam Screw O-ring	1	19712-SHW	19712-SHW	19712-SHW	19712-SHW	19712-SHW	19712-SHW
10	Cam	1	18271-SHW	18271-SHW	18271-SHW	18271-SHW	18271-SHW	18271-SHW
11	Wear Plate-Pin Assy	1	24162-SHW	24162-SHW	24162-SHW	24162-SHW	24162-SHW	24162-SHW
12	Retaining Ring (Ext)	1/3	15952-SHW	15952-SHW	15952-SHW	15952-SHW	15952-SHW	15952-SHW
13	Washer	1	15959-SHW	15959-SHW	15959-SHW			
14/17	Mech Seal/Seat Assy	1	15955-SHW*	15955-SHW*	15955-SHW*	25115-SHW	25115-SHW	25115-SHW
15	Retaining Ring (Int)	1	15942-SHW	15942-SHW	15942-SHW	15942-SHW	15942-SHW	15942-SHW
16	Shaft/Bearing Assy	1	25100-SHW**	25100-SHW**	25100-SHW**	25100-SHW	25100-SHW	25100-SHW
18	Port	1	19236-SHW		19236-SHW	19236-SHW		19236-SHW
19	Port	1	19236-SHW		21988-SHW	19236-SHW		21988-SHW
20	Bolts	8	21484-SHW		21484-SHW	21484-SHW		21484-SHW
21	Lockwasher	8	21573-SHW		21573-SHW	21573-SHW		21573-SHW
22	Port Bracket	2	21373-SHW		21373-SHW	21373-SHW		21373-SHW
23	O-ring	2	21525-SHW		21525-SHW	21525-SHW		21525-SHW
	Minor Repair Kit		24580-SHW	24580-SHW	24580-SHW	25125-SHW	25125-SHW	25125-SHW
	Major Repair Kit		25126-SHW	25126-SHW	25126-SHW	25126-SHW	25126-SHW	25126-SHW

\* 15955-SHW is to be only used with the original shaft and bearing assembly. The original shaft and bearing assembly has a snap ring groove between the impeller and the first ball bearing. Do not use the 15955-SHW with the 25100-SHW shaft bearing assembly designed for the pressed-on seal seat.

\*\* When replacing the shaft bearing assembly with the 25100-SHW, the 25115-SHW mechanical seal kit must also be used. The 25100-SHW shaft and bearing assembly can be identified by the absence of the snap ring groove between the impeller and the first ball bearing. Do not use the 15955-SHW with the 25100-SHW assembly.



# 18000 Series Technical Guide

## Assembly/Disassembly Instructions

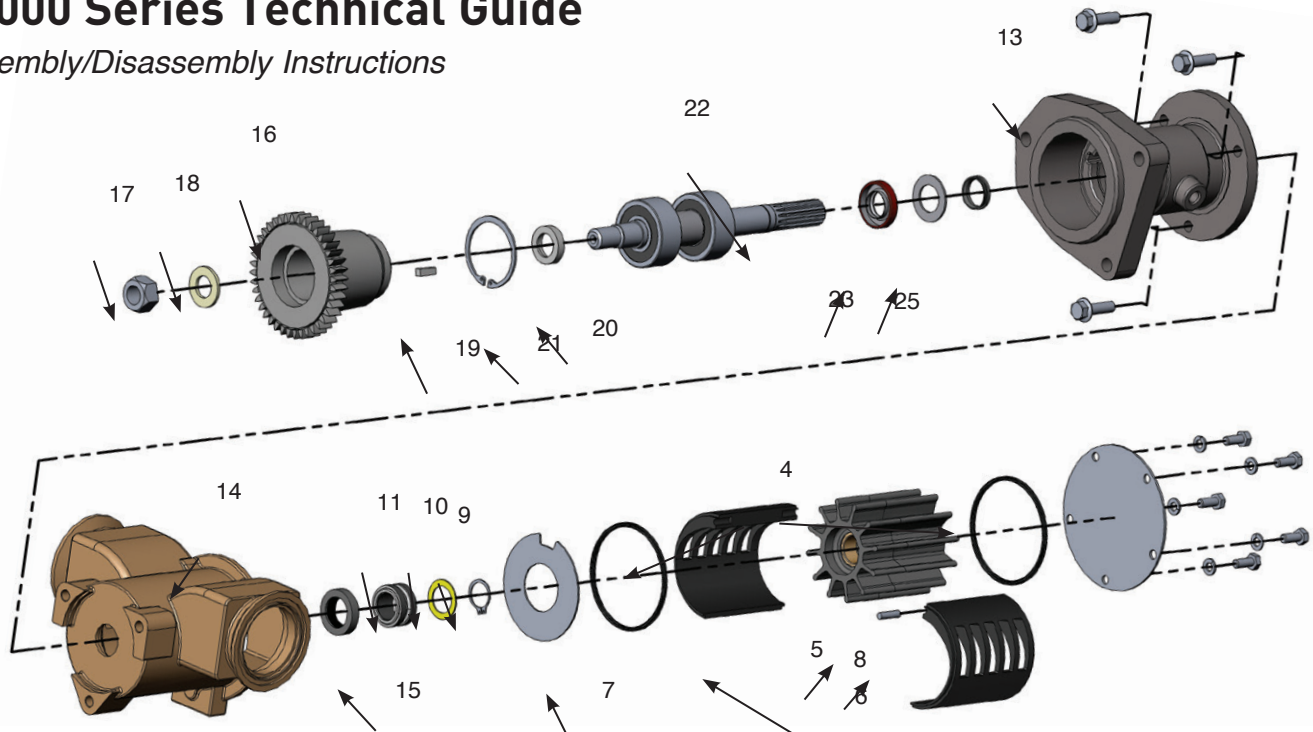

The following assembly/disassembly procedures apply to all 18000 Series pumps. Deviations from pump to pump are primarily a result of different methods of drive and mounting. Pump numbers can be found stamped into the cover plate of the pump.

### Disassembly:

- A. Remove the bolts (1) and lockwashers (2) from the cover (3).
- B. Remove the cover, quad rings (4), impeller (5), cam liner halves (6), and wearplate (7). Note the direction of the impeller blades to ensure proper replacement of the impeller during the assembly procedure. **Caution:** the pin (8) might fall out from its place between the cam liner halves. The impeller can be removed using impeller puller 23631, 25105, or a 3/4" x 16 UNF bolt.
- C. Using external snap ring pliers, remove the retaining ring (9) from the shaft.
- D. Slide the washer (10) and mechanical seal (11) off of the shaft.
- E. Remove the bolts (12) holding the body (13) to the housing (14).
- F. Slide the housing off of the shaft and body assembly.
- G. Press the seal seat (15) out of the housing.
- H. When applicable remove the drive gear assembly: while supporting the drive gear (16), remove the nut (17), nut washer (18), and key (19) from the shaft. Slide the gear off of the shaft and remove the thrust washer (20) behind the gear.
- I. Using internal snap ring pliers, remove the retaining ring (21) from the body. Remove the bearing shield (24) from the body.
- J. Press the bearing and shaft assembly (22) out of the body.
- K. Remove the lip seal (23) and washer (25) from the body.
- L. Inspect the shaft for grooving of the lip seal area and heavy fretting of the spline portion that drives the impeller. Inspect the bearings for loss of grease, corrosion, and rough rotation. If the shaft or bearings exhibit such a wear, replace the entire shaft and bearing assembly (22).

**Warning:** Do not try to build the shaft and bearing assembly from the individual parts, but instead purchase the entire shaft and bearing assembly. Due to extremely tight tolerances, special assembly procedures for this assembly must be followed to prevent galling of the shaft in the lip seal area.

### Assembly:

- A. Replace the washer (25) then press the lip seal (23) into the pump body (13) with the metal backing ring of the lip seal toward the housing (14) and away from the engine. Care should be taken to ensure proper alignment of the lip seal to the pump body and that the lip seal is uniformly pressed to prevent distortion.
- B. Press the shaft and bearing assembly (22) into the pump body.
- C. Slide the bearing shield (24) into the pump body and against the inner bearing.
- D. Using internal snap ring pliers, install the retaining ring (21) into the body.

# 18000 Series Technical Guide *(continued)*

- E. Press the mechanical seal seat (15) into the housing with the white ceramic seal face or gray silicon carbide face toward the impeller. Lubricate the outside of the seat boot with a water soluble lubricant or soapy water for easier assembly. Oil or grease must not be used as it will prevent the rubber cup assembly from properly gripping the housing. The seat should be inspected to ensure that the cup did not become partially dislodged during the assembly procedure.
- F. Slide the housing over the shaft and body assembly. Apply Loctite #262 or equivalent to the bolt threads. Fasten the three bolts (12) and torque them to 25 ft-lbs.
- G. When applicable, replace the drive gear assembly. Slide the thrust washer (20) onto the outer bearing. Place the key (19) in the shaft, then slide the gear (16) on the shaft. Apply Loctite #262 or equivalent to the shaft threads. Replace the washer (18), then tighten the nut (17) onto the shaft for the G1808, G18081-01, G18082-01 and G18082X. While supporting the drive gear, torque the nut to 270 ft-lbs. For all other models, refer to applicable engine manufacturer's torque requirements. 24007 contains 2 thrust washers. The G18082-01 utilizes the 23926 washer, which is .300" thick and 1.38" diameter of solid steel. The G1808 and G18081-01 use the 22779 washer, which is dimensionally the same, except it has a step in the internal diameter.
- H. Lubricate the inner rubber portion of the mechanical seal (11) with a water soluble lubricant or soapy water and slide the seal onto the shaft, with the carbon or silicon carbide portion of the mechanical seal toward the seal seat. Oil or grease must not be used as it will prevent the mechanical seal from properly gripping the shaft.
- I. Place the washer (10) onto the shaft and against the mechanical seal (see below to identify the proper washer) and then using external snap ring pliers, install the retaining ring (9) into the groove in the shaft to compress the mechanical seal.

## Seal Washer Selection

When replacing the mechanical seal, it is necessary to ensure the proper seal washer is used to avoid damage to the pump. It is recommended that all pumps be upgraded with the silicon carbide mechanical seal 23837, except for pump number G1810, G1810-01, G1810x, G1811-01, G1815-01, G1816-01, which can only be fitted with the 23512 seal. The G1814-01 and G1814x use the 24511 silicon carbide mechanical seal. Use the following to determine which washer to use:

- When using the silicon carbide mechanical seal 23837 for replacement, determine the proper spacer to use from the chart below. Silicon carbide is characterized by the charcoal gray-colored seal and seat faces, as opposed to carbon on ceramic, which would be black on white.
- Exceptions to the chart:
  - If the pump is to be fitted with the new shaft and bearing assembly listed on the chart on page 40 (24000, 24001, 24002, and 24003), use the 19866 washer. These shaft and bearing assemblies can only be used with the 23837 silicon carbide mechanical seals.
  - Replacement of the seal with the carbon on ceramic mechanical seal 19878 can only be performed on older units with the original shaft and bearing assemblies still in place. Use the 19866 spacer in such cases. Use of the 19878 seal with the current production units (G18061-01, G18071-01, and G18081-01) or with older units fitted with the new shaft and bearing assemblies will cause damage to the pump.
- J. Install the wearplate (7) with the hole in the plate lined up with the slot in the housing. Install the quad ring (4) into the housing

Pump Number	23837 Seal Spacer Number *
G1801	23840
G1804	23840
G1805	23840
G1806	23840
G18061-01	19866
G1807	23840
G18071-01	19866
G1808	23840
G18081-01	19866
G18082-01	19866
All Others**	N/A

**Note: If the pump is fitted with a silicon carbide seal, it must be replaced with the 23837 silicon carbide seal to prevent damage.**

*\*Note: The 19866 spacer is .060" thick and the 23840 is .260" thick.*

*\*\* G1810, G1810-01, G1811-01, G1815-01, G1816-01 use the 23512 seal only. The G1814-01 and G1814X use the 24511 silicon carbide mechanical seal.*

and on top of the wearplate.

- K. Create the cam assembly by connecting the cam halves (6) together and installing the pin (8) into the cam liner. A dab of grease can be used to hold the pin in place during installation. Place the cam assembly into the housing, ensuring that the pin aligns with the slot in the housing.
- L. Insert the impeller (5) in the housing using a twisting motion. Ensure that the impeller blades are bent in the same direction as upon removal (dependent on the pump model). For ease of installation, apply a silicon lubricant to the impeller. **Caution:** Do not use a petroleum-based lubricant (petroleum product will cause damage to the impeller).

# 18000 Series Technical Guide *(continued)*



Vanes flipped to the left  
(viewed from cover).

**Models:**  
G1808, G18081-01,  
G18082, G18082X,  
G1810, G1810-01,  
G1814-01, G1814X,  
G1811-01 and G1816-01



Vanes flipped to the right  
(viewed from cover).

**Models:**  
G1801, G1804, G1805,  
G1806, G18061-01, G1807,  
G18071-01 and G1815-01

M. Insert the remaining quad ring (4) into the groove, install the cover (3) on the housing, and then fasten the lockwashers (2) and bolts (1) to 8 ft.-lbs. torque.

N. After installation, inspect the pump seal, lip seal, body and housing areas for leaks.

Item	Sherwood #	QTY	G1801	G1804	G1805	G1806	G18061-01	G1807	G18071-01	G1808	G18081-01
1	Cap Screw	5	19626	19626	19626	19626	19626	19626	19626	19626	19626
2	Lockwasher	5	15944	15944	15944	15944	15944	15944	15944	15944	15944
3	Cover Plate	1	19837	19837	19837	19837	19837	19837	19837	19837	19837
4	Quad Rings	2	19879	21561	21561	21561	21561	21561	21561	21561	21561
5	Impeller	1	18000	18000	18000	18000	18000	18000	18000	18000	18000
6	Cam Liner Halves	2	19829	21533	21106	21533	21533	21106	21106	21533	21533
7	Wear Plate	1	19836	19836	19836	19836	19836	19836	19836	19836	19836
8	Pin	1		21566	21566	21566	21566	21566	21566	21566	21566
9	Retaining Ring	2	19762	19762	19762	19762	19762	19762	19762	19762	19762
10	Washer	1	19866	19866	19866	19866	19866	19866	19866	19866	19866
11/15	Mechanical Seal Assy	1	19878	19878	19878	19878	23837	19878	23837	19878	23837
12	Bolt	3	21172	21172	21172	21172	21172	21172	21172	21172	21172
13	Body	1	19827	21476	21920	21986	21986	21827	21827	22412	22412
14	Housing	1	19828	21565	21829	21829	21829	21829	21829	22762	22762
16	Gear	1								22789	22789
17	Nut	1								22790	22790
18	Washer	1								22788	22788
19	Key	1								22791	22791
20	Gear Spacer	1								22779	22779
21	Retaining Ring	1	19867	19867	19867	19867	19867	19867	19867	19867	19867
22	Bearing and Shaft Assy	1	24000	24001	24000	24001	24001	24001	24001	24002	24002
23	Lip Seal	1	19869	19869	19869	19869	19869	19869	19869	23045	23045
24	Bearing Shield	1									
25	Washer	1	19835	19835	19835	19835	19835	19835	19835	19835	19835
	Minor Repair Kit			24004	24023	24004	24004	24023	24023	24004	24004
	Major Repair Kit			24006	24024	24006	24006	24024	24024	24007	24007

\* When using these Shaft and Bearing Assemblies, replace the seal with the silicon carbide mechanical seal 23837 only. Use of the 19878 mechanical seal with these Shaft and Bearing Assemblies may cause pump damage. See "Seal Washer Selection" on page 47.

Item	Sherwood #	QTY	G18082-01	G18082X	G1810	G1810-01	G1810X	G1811-01	G1814-01	G1814X	G1815-01	G1816-01
1	Cap Screw	5	19626	19626	19626	19626	19626	19626	19626	19626	19626	19626
2	Lockwasher	5	15944	15944	15944	15944	15944	15944	15944	15944	15944	15944
3	Cover Plate	1	19837	19837	19837	19837	19837	19837	19837	19837	19837	19837
4	Quad Rings	2	21561	21561	21561	21561	21561	21561	21561	21561	21561	21561
5	Impeller	1	18000	18000	18000	18000	18000	18000S	18000S	18000	18000S	18000S
6	Cam Liner Halves	2	21533	21533	21106	21106	21106	21106	21106	21106	21533	21533
7	Wear Plate	1	19836	19836	19836	19836	19836	19836	19836	19836	19836	19836
8	Pin	1	21566	21566	21566	21566	21566	21566	21566	21566	21566	21566
9	Retaining Ring	2	19762	19762	19762	19762	19762	19762	19762	19762	19762	19762
10	Washer	1	19866	19866	19866	19866	19866	19866	19866	19866	19866	19866
11/15	Mechanical Seal Assy	1	23837	23837	23512	23512	23512	23512	24511	24511	23512	23512
12	Bolt	3	21172	21172	23296	23296	23296	23296	23296	23296	23296	23296
13	Body	1	23916	23916	23396	23396	23396	24174	23396	23396	24174	24174
14	Housing	1	22762	22762	23523	23523	23523	23523	23523	23523	23523	23523
16	Gear	1	22789	22789								
17	Nut	1	22790	22790								
18	Washer	1	22788	22788								
19	Key	1	22791	22791								
20	Gear Spacer	1	23926	23926								
21	Retaining Ring	1	19867	19867	19867	19867	19867	19867	19867	19867	19867	19867
22	Bearing and Shaft Assy	1	24463	24463	24003	24003	24003	24003	24003	24003	24003	24003
23	Lip Seal	1	23045	23045	23045	23045	23045	23045	23045	23045	19869	23045
24	Bearing Shield	1	23425	23425	23425	23425	23425	23425	23425	23425	23425	23425
25	Washer	1										
	Minor Repair Kit		24004	24004	24005	24005	24005	24005			24753	24760
	Major Repair Kit		24007	24007	24008	24008	24008	24008	24655	24655	24754	24761

# 22000 and 30000 Series Technical Guide

## Assembly/Disassembly Instructions

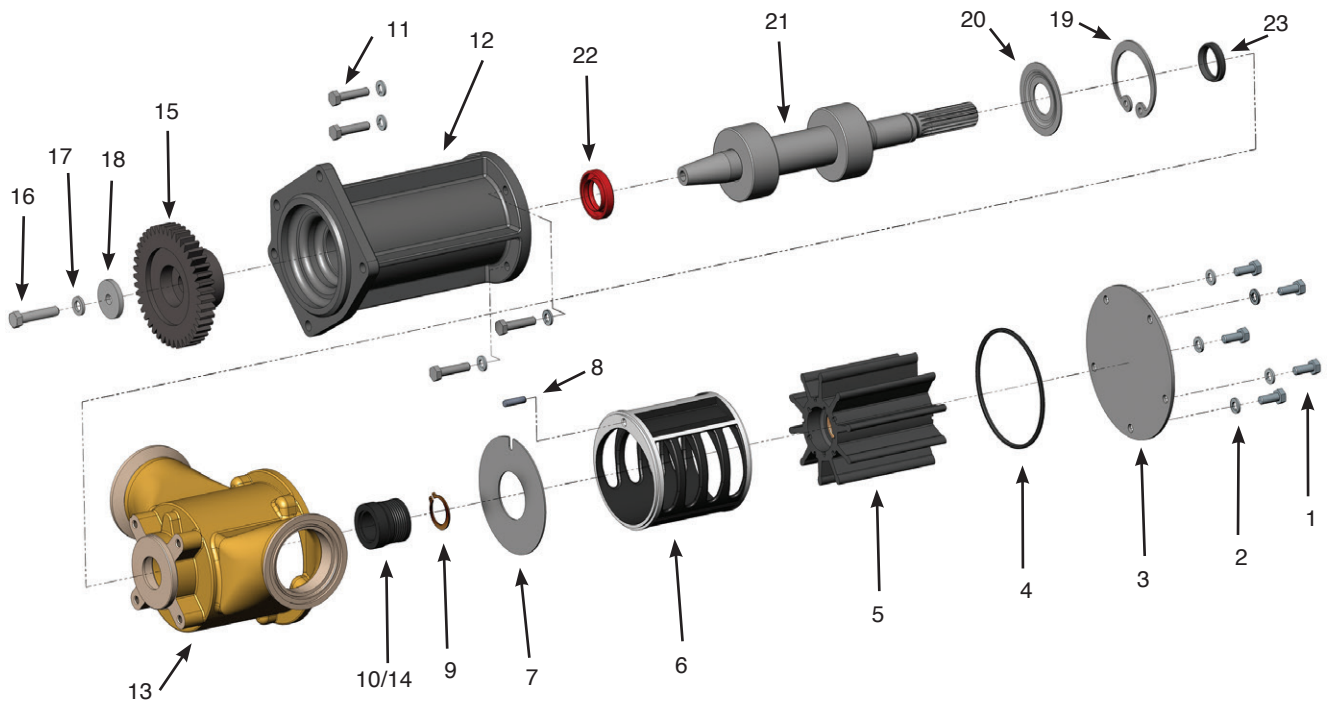

The following assembly/disassembly procedures apply to all G22000/G3000 Series pumps. Pump numbers can be found stamped into the cover plate of the pump.

### Disassembly:

- A. Remove the bolts (1) and lockwashers (2) from the cover (3).
- B. Remove the cover and quad ring (4). Note the direction of the impeller blades to ensure proper replacement of the impeller during the assembly procedure. The impeller (5) can be removed with impeller puller 23631, 25105, or a 3/4" - 16 bolt (by screwing the bolt into the threaded impeller, the impeller is jacked out of the pump).

**Caution:** The pin (8) might fall out from its place when removing the cam.

- C. The cam or cam halves (6), cam anti-rotation pin, and wearplate (7) can be removed.
- D. Using external snap ring pliers, remove the retaining ring (9) from the shaft.
- E. Slide the mechanical seal (10) off of the shaft.
- F. Remove the bolts (11) and lockwashers holding the body (12) to the housing (13).
- G. Slide the housing off of the shaft and body assembly.
- H. Press the seal seat (14) out of the housing.
- I. When applicable, remove the drive gear assembly: while supporting the drive gear (15), remove the bolt (16), lockwasher (17) and thrust washer (18) from the shaft. Pull the gear off of the tapered shaft using a bearing or wheel puller.
- J. Using internal snap ring pliers, remove the retaining ring (19) from the body. For the G22012-01, G22012X, G3001-01, G3001-02 and G3001X, remove the bearing shield (20) from the body.
- K. Press the bearing and shaft assembly (21) out of the body.
- L. Remove the lip seal (22) from the body.
- M. Inspect the shaft for grooving of the lip seal area and heavy fretting of the spline portion that drives the impeller. Inspect the bearings for loss of grease, corrosion and rough rotation. If the shaft or bearings exhibit such a wear, replace the entire shaft and bearing assembly (21) listed on page 51.



## 22000 and 30000 Series Technical Guide *(continued)*

**Warning:** Do not try to build the shaft and bearing assembly from the individual parts, but instead purchase the entire shaft and bearing assembly listed on this page. Due to tight tolerances, special assembly procedures for this assembly must be followed to prevent galling of the shaft in the lip seal area.

### Assembly:

- A. The lip seal (22) should be pressed in the body (12) with the metal backing ring of the lip seal toward the housing (13) and away from the engine.

**Caution:** For the G22012-01, G22012X, G3001-01, G3001-02 and G3001X, when pressing the lip seal in the body from the impeller end, the lip seal should be pressed 0.065" plus/minus 0.010" past the furthest bearing location. See detailed illustration. This position is critical to the performance of the oil seal since it needs to be placed slightly further than the bearing, but not as far as the beginning of the taper. Failure to place the seal at this location will cause the lip seal to contact the tapered portion of the shaft which will cause premature lip seal wear. Care should also be taken to ensure proper alignment of the lip seal to the pump body and that the lip seal is uniformly pressed to prevent distortion.

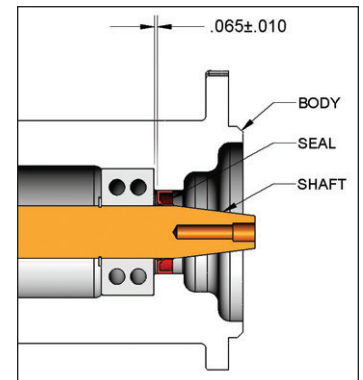

Close-up Drawing of Lip Seal Area

- B. Press the shaft and bearing assembly (21) into the pump body.  
For the G22012-01, G22012X, G3001-01, G3001-02 and G3001X, ensure that the lip seal will not wear on the tapered portion of the shaft (see Caution above). Replace the slinger (23) on the shaft between the mechanical seal position and the bearings.
- C. For the G22012-01, G22012X, G3001-01, G3001-02, G3001X, slide the bearing shield (20) into the pump body and against the inner bearing.
- D. Using internal snap ring pliers, install the retaining ring (19) into the body.
- E. Press the mechanical seal seat (14) into the housing (13) with the gray silicon carbide face toward the impeller. Lubricate the outside of the seat boot with a water soluble lubricant or soapy water for easier assembly. Oil or grease must not be used as it will prevent the rubber cup assembly from properly gripping the housing. The seat should be inspected to ensure that the cup did not become partially dislodged during the assembly procedure.
- F. Slide the housing over the shaft and body assembly. Fasten the four bolts (11) and lockwashers, and torque them to 12-16 ft-lbs.
- G. Replace the drive gear assembly. Slide the gear (15) on the shaft. Place the thrust washer (18) on the gear and against the shaft. Place the lockwasher (17) on the bolt (16), and then apply Loctite #262 or equivalent to the bolt. Fasten the bolt to the shaft and torque it to 36 ft-lbs.
- H. Lubricate the internal rubber portion of the mechanical seal (10) with a water soluble lubricant or soapy water and slide the seal onto the shaft with the silicon carbide portion of the mechanical seal toward the seal seat. Oil or grease must not be used as it will prevent the mechanical seal from properly gripping the shaft.
- I. Using external snap ring pliers, replace the retaining ring (9) on the shaft.
- J. Install the pin (8) into the housing.
- K. Install the wear plate (7) with the hole in the plate aligned with the pin in the housing.
- L. Place the cam (6) in the housing. For the plastic cam halves, create the cam assembly by connecting the cam halves (6) together. Align the hole in the cam with the pin in the housing and ensure the anti-rotation pin is in place after the cam is fully installed.
- M. Insert the impeller (5) in the housing using a twisting motion. Ensure that the impeller blades are bent in the same direction as upon removal (counterclockwise when viewed from the cover). For ease of installation, apply a silicon lubricant to the impeller.
- Caution:** DO NOT USE A PETROLEUM-BASED LUBRICANT (petroleum product will cause damage to the impeller).
- N. Insert the quad ring (4) into the groove, install the cover (3) on the housing, and then fasten the lockwashers (2) and bolts (1). Torque the cover bolts to 5-8 ft-lbs.
- O. After installation, inspect the seal, body, housing and cover for leaks.

# 22000 and 30000 Series Technical Guide

Sherwood #			G2201	G22011-01	G22012-01	G22012X	G3001-01	G3001-02	G3001X
Item		QTY							
1	Cap Screw	5	19626	19626	19626	19626	19626	19626	19626
2	Lockwasher	9	15944	15944	15944	15944	15944	15944	15944
3	Cover Plate	1	23113	23113	23113	23113	23113	23113	23113
4	Quad Ring	1	23111	23111	23111	23111	23111	23111	23111
5	Impeller	1	22000	22000	22000	22000	30000	30000	30000
6	Cam/Cam Half	1/2	24160	24160	24160	24160	24160	25072	25072
7	Wear Plate	1	23112	23112	23112	23112	23112	23112	23112
8	Pin	1	21566	21566	21566	21566	21566	21566	21566
9	Retaining Ring	1	23115	23115	23115	23115	23115	23115	23115
10/14	Mechanical Seal Assy.	1	23087	23906	23906	23906	23906	23906	23906
11	Bolt	4	23211	23211	23211	23211	23211	23211	23211
12	Body	1	23056	23056	23919	23919	23919	23919	23919
13	Housing	1	23057	24299	24159	24159	24159	24159	24159
15	Gear	1	23181	23181	23181	23181	23181	23181	23181
16	Bolt	1	23194	23194	23194	23194	23194	23194	23194
17	Lockwasher	1	23196	23196	23196	23196	23196	23196	23196
18	Thrust Washer	1	23195	23195	23195	23195	23195	23195	23195
19	Retaining Ring	1	23091	23091	23091	23091	23091	23091	23091
20	Bearing Shield	1			23922	23922	23922	23922	23922
21	Bearing and Shaft Assy.	1	24464	24464	24464	24464	25153	25153	25153
22	Lip Seal	1	23088	23088	23088	23088	23088	23088	23088
23	Slinger	1			23924	23924	23924	23924	23924
	Minor Repair Kit		24870	24870	24870	24870	25017	25017	25017



## 26000 Series Technical Guide

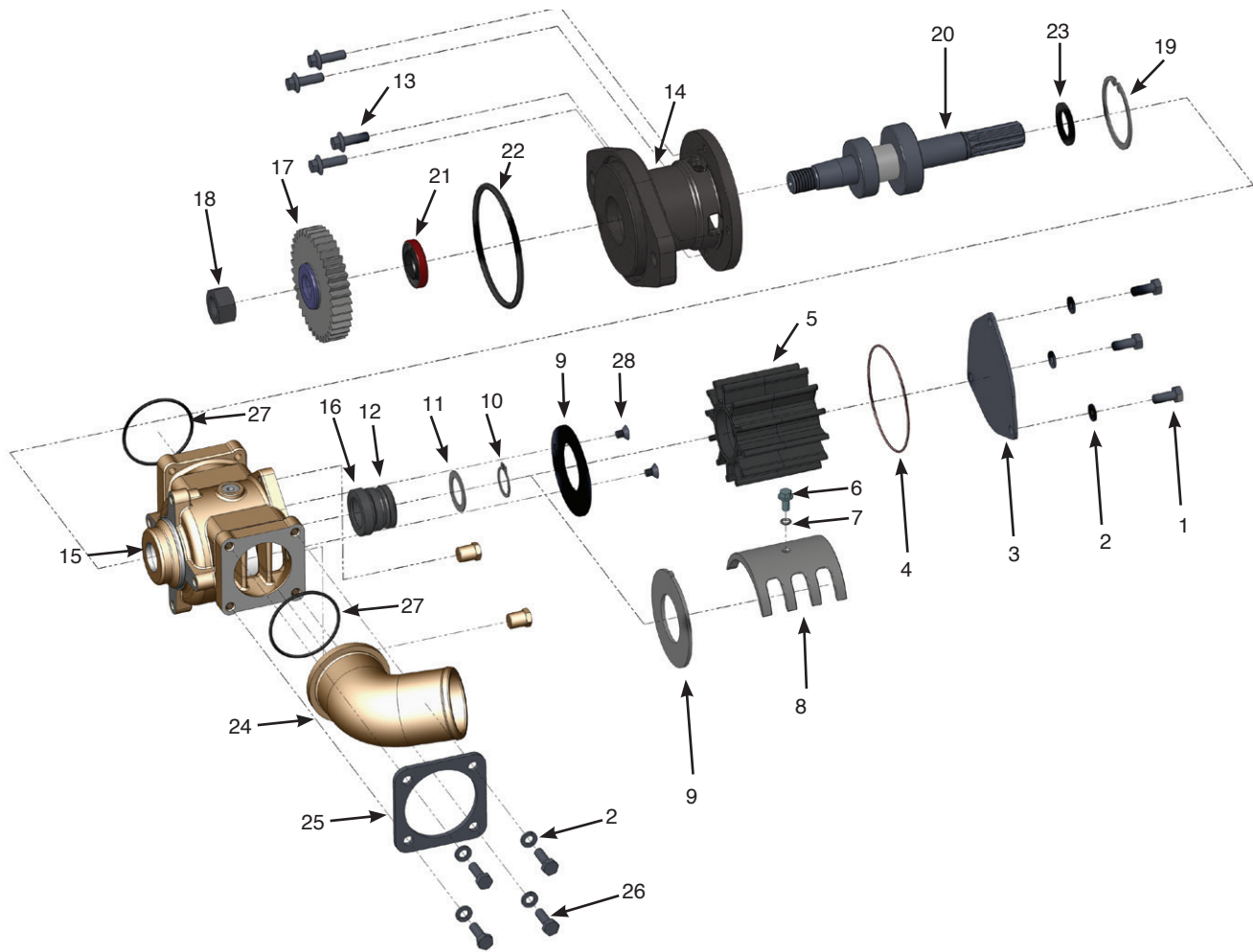

### Disassembly:

**Note:** It may not be necessary to perform the entire disassembly procedure for the intermediate and minor kits.

- A. Remove the bolts (1) and lockwashers (2) from the cover (3).
- B. Remove the cover, o-ring (4), and impeller (5), using puller number 23631, 251055, or 3/4" x 16 UNF bolt. Note the direction of the impeller blades to ensure proper replacement of the impeller during the assembly procedure.
- C. When applicable, remove the cam screw (6) and cam screw o-ring (7) from the cam. The cam (8) and wearplate (9) can now be taken out of the housing.
- D. For the G2603, G2604 and G2605 pump models with integrated cam designs, remove the two wearplate flat head screws (28) holding the wearplate in place.
- E. Using external snap ring pliers, remove the retaining ring (10) from the shaft.
- F. Slide the washer (11) and mechanical water seal (12) off of the shaft.
- G. Remove the bolts (13) holding the body (14) to the housing (15).
- H. Slide the housing off of the shaft and body assembly.
- I. Press the seal seat (16) out of the housing.
- J. Remove the drive gear assembly. While supporting the drive gear (17), remove the nut (18) from the shaft.
- K. Using internal snap ring pliers, remove the retaining ring (19) from the body.
- L. Press the bearing and shaft assembly (20) out of the body.
- M. Remove the lip seal (21) and o-ring (22) from the body.
- N. Inspect the shaft for grooving of the lip seal area and heavy fretting of the spline portion that drives the impeller. Inspect the bearings for loss of grease, corrosion and rough rotation. If the shaft or bearings exhibit such a wear, replace the entire shaft and bearing assembly (20).

## 26000 Series Technical Guide *(continued)*

### Assembly:

**Warning:** Do not try to build the shaft and bearing assembly from the individual parts, but instead purchase the kit with entire shaft and bearing assembly. Special assembly procedures for this assembly must be followed to prevent galling of the shaft in the lip seal and mechanical seal area, which could cause premature seal leaks.

- A. Replace the o-ring (22) in the pump body (14), then press the lip seal (21) in place with the metal backing ring of the lip seal toward the housing (15) and away from the engine, until it is flush with the body surface. Care should be taken to ensure proper alignment of the lip seal to the pump body and that the lip seal is uniformly pressed to prevent distortion.
- B. Press the shaft and bearing assembly (20) into the pump body. Preferably, use a sleeve or piece of tubing, slightly bigger than the shaft (25mm) or about an 1" opening, to push against the inner race of the ball bearing.
- C. Using internal snap ring pliers, install the retaining ring (19) into the body. Then slide the slinger (23) onto the impeller end of the shaft to about 1/8" away from the bearings.
- D. Press the mechanical seal seat (15) into the housing with the gray silicon carbide face toward the impeller. Lubricate the out side of the seat boot with a water-soluble lubricant or soapy water for easier assembly. Oil or grease must not be used, as it will prevent the rubber cup assembly from properly gripping the housing. The seat should be inspected to ensure that the cup did not become partially dislodged during the assembly procedure.
- E. Slide the housing (15) over the shaft and body assembly. Use Loctite® Primer and Loctite® 262 or equivalent on the body to housing bolts. Fasten the three bolts (13) and torque them to 18 ft-lbs.
- F. When applicable, replace the drive gear assembly. Use Loctite® Primer and Loctite® 262 or equivalent on the gear nut. Slide the gear (17) on the shaft, and then tighten the nut (18) onto the shaft. While supporting the drive gear, torque the nut to 130-140 ft-lbs.
- G. Lubricate the inner rubber portion of the mechanical water seal (12) with a water soluble lubricant or soapy water and slide the seal onto the shaft, with the silicon carbide portion of the mechanical water seal (12) toward the seal seat (16).  
**Note:** The two mating surfaces must be the gray silicon carbide portion of the seal to the gray silicon carbide portion of the seal seat. Oil or grease must not be used to prevent the mechanical seal from properly gripping the shaft.
- H. Place the washer (11) onto the shaft and then using external snap ring pliers, install the retaining ring (10) into the groove in the shaft to compress the mechanical seal.
- I. Install the wearplate (9) with the anti-rotation tab into the recess in the housing.
- J. For the G2603, G2604 and G2605 pump models with integrated cam designs, apply Loctite® 242 to the wearplate flat head screw threads (28), replace the two screws to secure the wear plate, and torque them to 50 in-lbs.
- K. When applicable, replace the cam (8) in the housing. Place the cam screw o-ring (7) onto the cam screw (6) and then fasten the cam screw in place.
- L. Insert the impeller (5) in the housing using a twisting motion. Ensure that the impeller blades are bent in the same direction as upon removal. For ease of installation, apply a silicon lubricant to the impeller. **Caution:** Do not use a petroleum-based lubricant (petroleum product will cause damage to the impeller).
- M. Insert the O-ring (4) into the groove, install the cover (3) on the housing, and then fasten the lockwashers (2) and bolts (1) to 8 ft-lbs. torque.
- N. If necessary to replace the port elbow, slide the port (24) through the bracket (25). Replace the o-ring (27). Fasten the lockwashers and bolts (26) through the port bracket to the housing and torque to 12 ft-lbs.
- O. After installation, inspect the seals, housing, body and cam areas for leaks.

## 26000 Series Technical Guide

Item	Sherwood #	QTY	G2601-01	G2601-02	G2601-03	G2601X	G2602-01
1	Cap Screw	3	19626	19626	19626	19626	19626
2	Lockwasher	3/7	21573	21573	21573	21573	21573
3	Cover Plate	1	24074	24074	24074	24074	24074
4	O-Ring	1	19879	19879	19879	19879	19879
5	Impeller	1	26000	26000	26000	26000	26000
6	Cam Screw	1	19714	19714	19714	19714	19714
7	O-Ring	1	19712	19712	19712	19712	19712
8	Cam	1	24075	24075	24075	24075	24075
9	Wear Plate	1	24073	24073	24073	24073	24073
10	Retaining Ring	1	19762	19762	19762	19762	19762
11	Washer	1	19866	19866	19866	19866	19866
12/16	Mechanical Seal Assy	1	23837	23837	23837	23837	23837
13	Bolt	4	19708	19708	19708	19708	19708
14	Body	1	24102	24102	24102	24102	24102
15	Housing	1	24072	24072	24072	24072	24072
17	Gear	1	24083	24083		24083	24083
18	Nut	1	24084	24084	24084	24084	24084
19	Retaining Ring	1	19867	19867	19867	19867	19867
20	Shaft & Bearing Assy	1	24223	24223	24223	24223	24223
21	Lip Seal	1	19869	19869	19869	19869	19869
22	O-Ring	1	1720-0212	1720-0212	1720-0212	1720-0212	1720-0212
23	Slinger	1	24079	24079	24079	24079	24079
24	Port Elbow	1	24076				24132
25	Bracket	1	24081				24081
26	Cap Screw	4	21484				21484
27	O-Ring	2	24052				24052
28	Screw	2					
	Minor Repair Kit		24227	24227	24227	24227	24227
	Major Repair Kit		24840	24840	24840	24840	24228

Item	Sherwood #	QTY	G2603-01	G2603-02	G2603-03	G2603X	G2604-01	G2605-01
1	Cap Screw	3	19626	19626	19626	19626	19626	19626
2	Lockwasher	3/7	21573	21573	21573	21573	21573	21573
3	Cover Plate	1	24074	24074	24074	24074	24074	24074
4	O-Ring	1	19879	19879	19879	19879	19879	19879
5	Impeller	1	26000	26000	26000	26000	26000	26000
6	Cam Screw	1	19714	19714	19714	19714	19714	19714
7	O-Ring	1	19712	19712	19712	19712	19712	19712
8	Cam	1						
9	Wear Plate	1	24790	24790	24790	24790	24790	24790
10	Retaining Ring	1	19762	19762	19762	19762	19762	19762
11	Washer	1	19866	19866	19866	19866	19866	19866
12/16	Mechanical Seal Assy	1	23837	23837	23837	23837	23837	23837
13	Bolt	4	19708	19708	19708	19708	19708	19708
14	Body	1	24102	24102	24102	24102	24102	24102
15	Housing	1	24789	24789	24789	24789	24789	24789
17	Gear	1	24083	24083			24083	24083
18	Nut	1	24084	24084		24084	24084	24084
19	Retaining Ring	1	19867	19867	19867	19867	19867	19867
20	Shaft & Bearing Assy	1	24223	24223	24223	24223	24223	24223
21	Lip Seal	1	19869	19869	19869	19869	19869	19869
22	O-Ring	1	1720-0212	1720-0212	1720-0212	1720-0212	1720-0212	1720-0212
23	Slinger	1	24079	24079	24079	24079	24079	24079
24	Port Elbow	1	24076				24132	24630
25	Bracket	1	24081		24081		24081	24081
26	Cap Screw	4	21484		21484		21484	21484
27	O-Ring	2	24052	24052	24052		24052	24052
28	Screw	2	24840	24840	24840	24840	24840	24840
	Minor Repair Kit		24841	24841	24841	24841	24841	24841
	Major Repair Kit		24842	24842	24842	24842	24842	24842

# 29000 Series Technical Guide

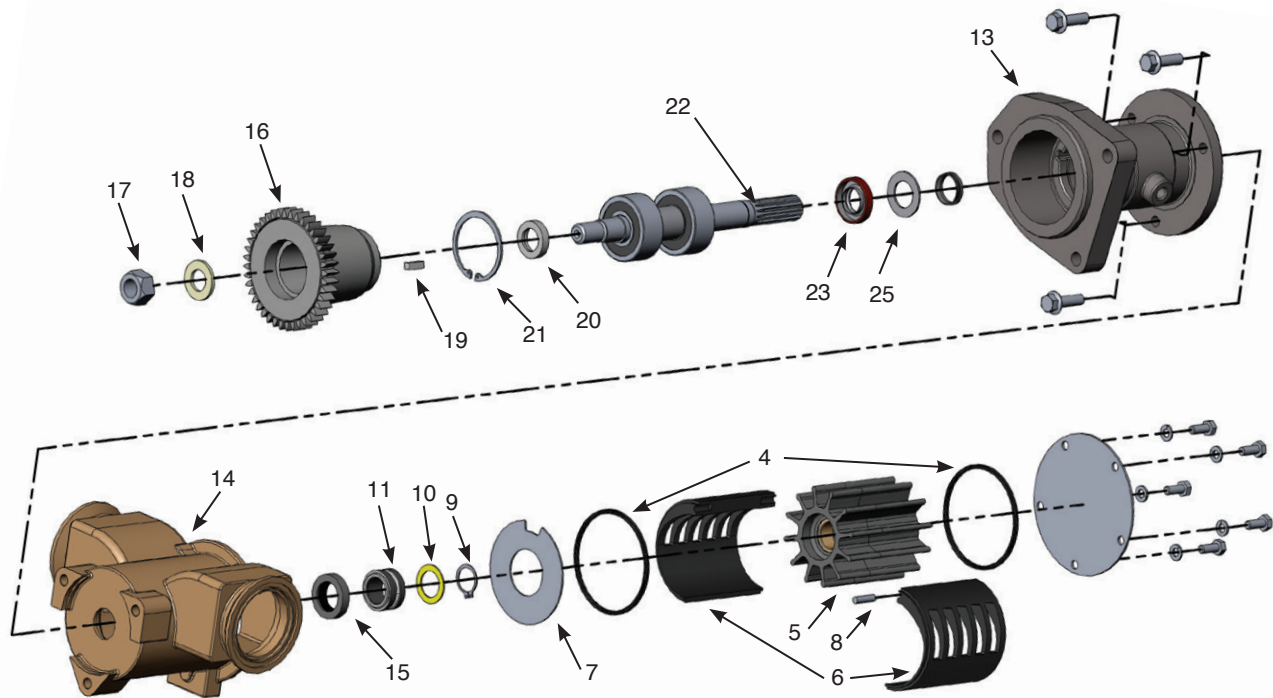

The following assembly/disassembly procedures apply to all 29000 Series pumps. Deviations from pump to pump are primarily a result of different methods of drive and mounting. Pump numbers can be found stamped into the cover plate of the pump.

## Disassembly:

- A. Remove the bolts (1) and lockwashers (2) from the cover (3).
- B. Remove the cover, quad rings (4), impeller (5), cam liner halves (6), and wearplate (7). Note the direction of the impeller blades to ensure proper replacement of the impeller during the assembly procedure. Caution: the pin (8) might fall out from its place between the cam liner halves. The impeller can be removed using impeller puller 23631, 25105, or a 3/4" x 16 UNF bolt.
- C. Using external snap ring pliers, remove the retaining ring (9) from the shaft.
- D. Slide the washer (10) and mechanical seal (11) off of the shaft.
- E. Remove the bolts (12) holding the body (13) to the housing (14).
- F. Slide the housing off of the shaft and body assembly.
- G. Press the seal seat (15) out of the housing.
- H. When applicable remove the drive gear assembly: while supporting the drive gear (16), remove the nut (17), nut washer (18), and key (19) from the shaft. Slide the gear off of the shaft and remove the thrust washer (20) behind the gear.
- I. Using internal snap ring pliers, remove the retaining ring (21) from the body. Remove the bearing shield (24) from the body.
- J. Press the bearing and shaft assembly (22) out of the body.
- K. Remove the lip seal (23) and washer (25) from the body.
- L. Inspect the shaft for grooving of the lip seal area and heavy fretting of the spline portion that drives the impeller. Inspect the bearings for loss of grease, corrosion, and rough rotation. If the shaft or bearings exhibit such a wear, replace the entire shaft and bearing assembly (22) listed on page 57.

**Warning:** Do not try to build the shaft and bearing assembly from the individual parts, but instead purchase the entire shaft and bearing assembly listed below. Due to extremely tight tolerances, special assembly procedures for this assembly must be followed to prevent galling of the shaft in the lip seal area.

## Assembly:

- A. Replace the washer (25) then press the lip seal (23) into the pump body (13) with the metal backing ring of the lip seal toward the housing (14) and away from the engine. Care should be taken to insure proper alignment of the lip seal to the pump body and that the lip seal is uniformly pressed to prevent distortion.
- B. Press the shaft and bearing assembly (22) into the pump body.

**29000 Series Technical Guide** *(continued)*



Vanes flipped to the left  
(viewed from cover).

**Models:** G2902-01, G2902X, G2903-01,  
G2903-02, G2903X

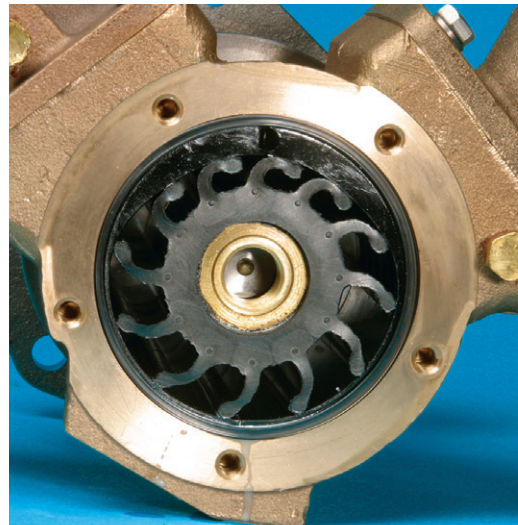

Vanes flipped to the right  
(viewed from cover).

**Models:** G2904-01, G2904X



# 29000 Series Technical Guide

Sherwood #		G2902-01	G2902X	G2903-01	G2903-02	G2903X	G2904-01	G2904X
Item	QTY							
1	Cap Screw	5	19626-SHW	19626-SHW	19626-SHW	19626-SHW	19626-SHW	19626-SHW
2	Lockwasher	5	15944-SHW	15944-SHW	15944-SHW	15944-SHW	15944-SHW	15944-SHW
3	Cover Plate	1	19837-SHW	19837-SHW	19837-SHW	19837-SHW	19837-SHW	19837-SHW
4	Quad Ring	2	21561-SHW	21561-SHW	21561-SHW	21561-SHW	21561-SHW	21561-SHW
5	Impeller	1	29000-SHW	29000-SHW	29000-SHW	29000-SHW	29000-SHW	29000-SHW
6	Cam Liner Halves	2	21533-SHW	21533-SHW	21106-SHW	21106-SHW	21106-SHW	21106-SHW
7	Wear Plate	1	19836-SHW	19836-SHW	19836-SHW	19836-SHW	19836-SHW	19836-SHW
8	Pin	1	21566-SHW	21566-SHW	21566-SHW	21566-SHW	21566-SHW	21566-SHW
9	Retaining Ring	2	19762-SHW	19762-SHW	19762-SHW	19762-SHW	19762-SHW	19762-SHW
10	Washer	1	19866-SHW	19866-SHW	19866-SHW	19866-SHW	19866-SHW	19866-SHW
11/15	Mechanical Seal Assy.	1	23837-SHW	23837-SHW	24511-SHW	24511-SHW	24511-SHW	23837-SHW
12	Bolt	3	21172-SHW	21172-SHW	21172-SHW	21172-SHW	21172-SHW	21172-SHW
13	Body	1	23916-SHW	23916-SHW	23396-SHW	23396-SHW	23396-SHW	21827-SHW
14	Housing	1	24623-SHW	24623-SHW	23523-SHW	23523-SHW	23523-SHW	21829-SHW
16	Gear	1	22789-SHW	22789-SHW				
17	Nut	1	22790-SHW	22790-SHW				
18	Washer	1	22788-SHW	22788-SHW				
19	Key	1	22791-SHW	22791-SHW				
20	Gear Spacer	1	23926-SHW	23926-SHW				
21	Retaining Ring	1	19867-SHW	19867-SHW	19867-SHW	19867-SHW	19867-SHW	19867-SHW
22	Bearing and Shaft Assy.	1	25145-SHW	25145-SHW	25103-SHW	25103-SHW	25103-SHW	25112-SHW
23	Lip Seal	1	23045-SHW	23045-SHW	23045-SHW	23045-SHW	23045-SHW	19869-SHW
24	Bearing Shield	1	23425-SHW	23425-SHW	23425-SHW	23425-SHW	23425-SHW	
	Minor Repair Kit		25146-SHW	25146-SHW	25044-SHW	25044-SHW	25044-SHW	25146-SHW



## Preventative Maintenance and Inspection

Maintenance Schedule	Pleasure Boating (Low Hours)		Commercial/Fishing Use (High Hours)	
	Light Duty	Severe Duty (High RPM, Silt or Sand)	Heavy Duty	Severe Duty (High RPM, Silt or Sand)
Impeller Kit	Every year	6 - 12 months	6 - 12 months	3 - 6 months
Minor Kit	2 years	Every year	Every year	6 months
Major Kit	4 years	2 years	2 years	Every year

\* See pages 16-31 for Repair Kit Part Numbers.

*The #1 reason for premature engine wear is overheating.*

*To maintain engine performance, insist upon genuine Sherwood impellers and service kits.*

### Recommended inspection to be performed at any service interval:

- Impeller ..... Inspect for cracks or tears. Also, inspect for excessive abrasion of vane ends.  
Replace annually, or if any of the conditions exist, as in the picture.
- Wear Plate ..... Inspect for wear, flatness, and pin for fatigue.  
Replace at major pump rebuild or if wear is evident to maintain pump flow and suction performance.
- Cam ..... Replace at minor or major pump rebuild or if pitting/wear is evident.
- Cover ..... Replace at major pump rebuild or if wear exists to maintain pump flow and suction performance.
- Mechanical Seal ..... Replace at minor and major pump rebuild or if leaking.
- Lip Seal ..... Replace at major pump rebuild or if leaking.
- Shaft ..... Inspect for wear in area of lip seal and rubber impeller. Grooving of lip seal area or heavy fretting of the impeller end shaft will require shaft replacement.
- Bearing ..... Inspect for loss of grease, corrosion or rough rotation. Replace at major pump rebuild.

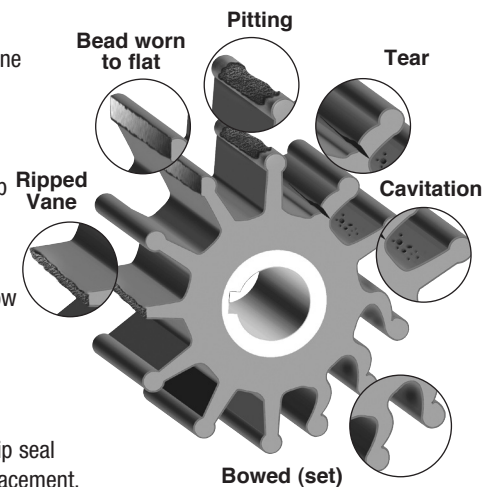

# Sherwood Tech Tips

To maintain best engine performance and to prolong engine life - replace your impeller annually.

Three tips to help you install your new impeller:

- Use a non-petroleum based lubricant (silicon or soapy water) to help slide the impeller into the housing.
- Install the impeller with a twisting motion onto the shaft. Never force an impeller onto the shaft. The impeller must be able to move freely on the shaft to properly prime and function.
- Use a small amount of non-petroleum based lubricant to help hold the o-ring when replacing the cover.

Proper storage of the impellers during a prolonged lay-up can help maintain the life of the impeller. Remove the impeller from the housing and store in a cool, dark place. This will avoid the following:

- Copper bonding of the impeller to the housing
- Ultraviolet deterioration
- Vanes “setting” into position as stored in the housing

## How Does a Rubber Impeller Pump Work?

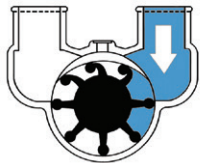

**1** A self-priming vacuum is created as the flexible impeller vanes straighten upon leaving the cam, drawing liquid into the pump.

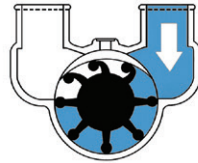

**2** The rotating impeller carries liquid from the inlet to the outlet port. As a consequence of their design, flexible impeller pumps can pass fairly large solids.

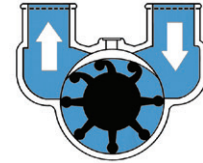

**3** When the flexible impeller vanes regain contact with the cam, they bend and the liquid is discharged from the pump in a uniform flow. Liquids can be pumped in the opposite direction by reversing the rotation of the pump.

## Which is my inlet and which is my outlet port?

If you locate the cam and know which way the pump is rotating, you can figure out which port is which.

Cam (Held in place with single screw in-between the ports)

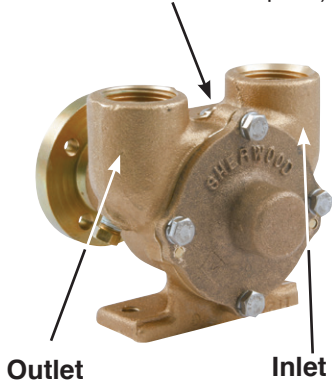

Integrated Cam with no screw (The smallest span between the ports is where the cam is located.)

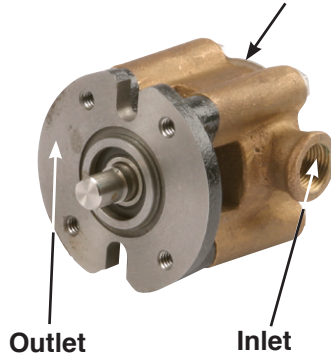

Cam (Held in place with single screw in-between the ports)

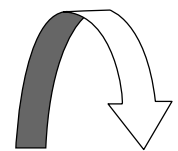
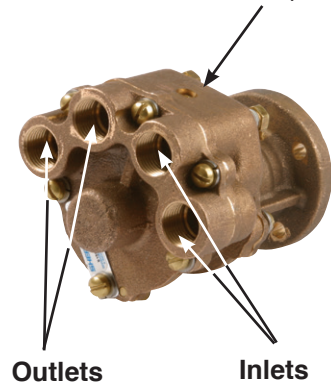

Clockwise Rotation