

Another neat, simple, winning solution from **Seals-It**

NEW! SPRINT CAR

Torque-Ball Seal

- **No dirt keeps Torque-Ball free!**
- **There is no contact between seal and crankshaft, so there is no added drag**
- **Does not interfere with fast engine removal**
- **Rubber seal is bonded by a patented process to precision machined anodized aluminum**



*Keeps the dirt
out of the bell
housing!*

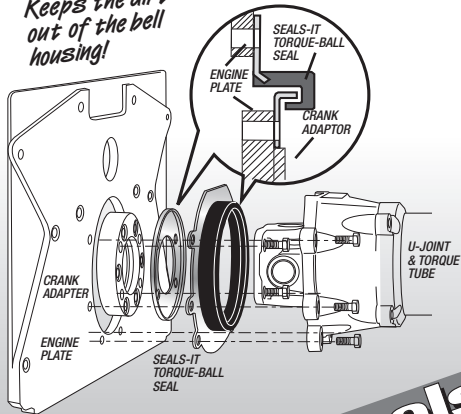

*PATENT PENDING

Seals-it