



Driven Beyond Perfection

LeMans Style Gas Door CSX-9030-A

INSTALLATION INSTRUCTIONS

APPLICATION: 1964 - 1966 and 1970* - 1973 Mustang

*Twist on cap is not compatible with 1970 California Emissions cars.

Thank you for purchasing another quality Scott Drake product. Please refer to the installation instructions below when installing this part.

Note: This gas door will not fit 1967-1968 Mustangs due to interference with the trunk lock. It can be made to fit on 1969 Mustangs with some clearancing on the back of the assembly.

TOOLS REQUIRED:

- ¼ INCH SLOTTED SCREWDRIVER
- #2 PHILLIPS SCREWDRIVER
- 3MM HEX KEY WRENCH
- 5/16 NUT DRIVER
- 3/8 OPEN END WRENCH

KIT INCLUDES:

- 1 - POLISHED ALUMINUM GAS CAP COVER ASSEMBLY
- 1 - COVER MOUNTING PLATE
- 1 - VENTED GAS CAP
- 5 - #12 X 5/8 SHEET METAL SCREWS
- 6 - M5X.8 X 12 FLATHEAD SOCKET SCREWS
- 1 - 10-24 X 7/8 MACHINE SCREW
- 1 - 10-24 LOCK NUT

INSTALLATION INSTRUCTIONS:

WARNING: Always wear protective eye-wear when working on your vehicle. Disconnect the battery. Be sure to work in a well ventilated space away from sparks, flames or heat sources. If any part of this installation seems beyond your level of experience, please seek the help of a professional installer.

Note: The included mounting plate allows the LeMans gas door to be mounted with the latch in the up, down, left or right position. From the factory, the door assembly is set to open to the left. To change the door position, disassemble the door from the mounting plate using a hex wrench and rotate the door to the desired position.

1. Remove the factory gas cap and security cable if equipped.
 2. Depending on how your vehicle is equipped you will need to use either a 5/16 nut driver or a phillips screwdriver, remove the sheet metal screws from the filler neck flange (Pic 1).
 3. Install the new gas cap in to the filler neck.
 4. Position the new gas door over the fuel neck and align the mounting holes with the existing holes around the fuel neck. Using a phillips screwdriver, install the included sheet metal screws and secure the fuel door.
- Note:** On cars equipped with a gas cap security cable, use the included 10-24 machine screw and lock nut in the hole used to attach the cable.



IMPORTANT WARNING

Always use a twist on vented gas cap in conjunction with this door assembly to prevent gas spills.

Pic 1



Figure 2

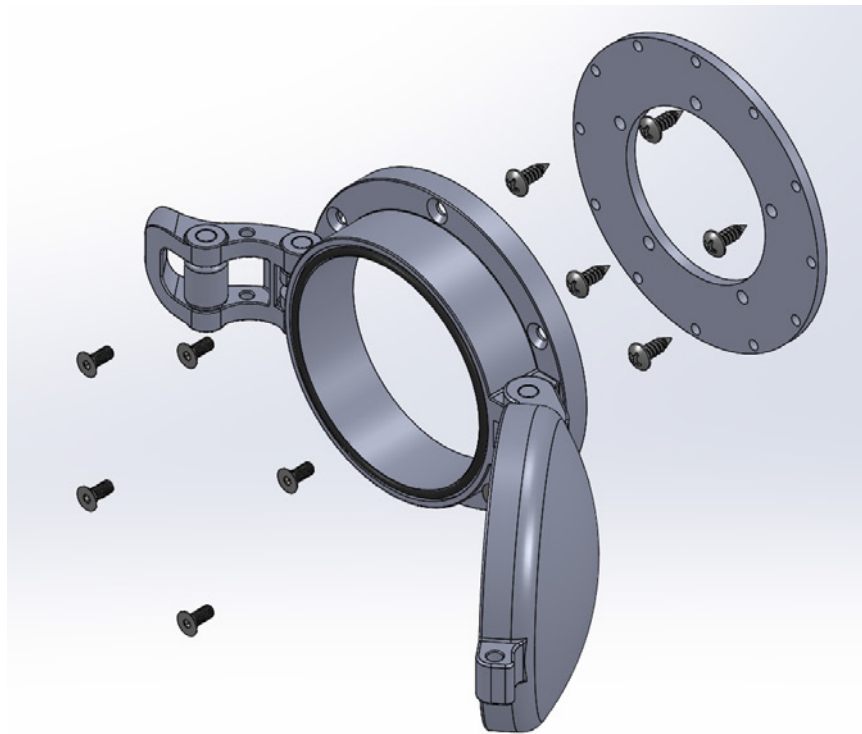
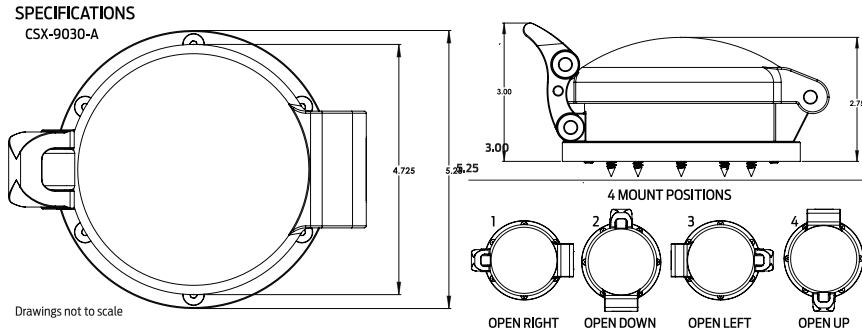

Figure 3



5. Check to make sure that the gas door opens and closes properly and the gas cap can be installed and removed without interference.

Optional Mounting Positions: To position the gas door to open in a different direction, remove the socket head screws from the door assembly and rotate the mounting plate to achieve the desired position. **Check to make sure there is no interference with the door assembly opening and closing properly.** Then reinstalled the socket head screws and machine screws.



CSX-9030-A (exploded view)

Also available from Scott Drake:

Bullet Style Mirrors



C5RZ-17696-AL

Sidewinder™ Billet Tail Light Bezels



B-13489-C