



Driven Beyond Perfection

BILLET ANTENNA INSTALLATION GUIDE

C5ZZ-18813-BL

APPLICATION: 1965- Early 1968 Mustang

Thank you for choosing quality Scott Drake products for your vehicle. Please refer to the installation instructions below when installing this part.

WARNING: Always wear protective eye-wear when working on your vehicle. Disconnect the battery. If any part of this installation seems beyond your level of experience, please seek the help of a professional installer.

INSTALLATION:

1. Remove existing antenna by disconnecting antenna socket from radio and removing cable from any fasteners, clips, etc. that may be in place. Make sure antenna mast is fully extended and remove antenna nut while holding on to antenna mast. Allow antenna assembly to rest in bottom of area between fender and inner fender. Remove antenna base. Pull up on antenna assembly, working it out of the antenna hole and pull out the antenna lead. Save the wedge (#5 in diagram) for reuse in the new billet antenna assembly. If needed it can be purchased separately under P/N: C5ZZ-18A915-A.

2. If necessary, loosen thread cap (cap used to protect mast-threads) on new antenna assembly (1) to expose approximately 1/4 inch of thread. Loop strong twine, fishing line, etc. around threads and tie a firm knot. Leave enough length to ensure other end of twine or line will not fall into antenna hole. This is to ensure antenna assembly does not end up in area between inner fender and fender with no easy means of retrieval.

3. Route antenna wire through antenna hole in fender and kick panel hole. Pull grommet (2) through hole until seated. Install antenna socket into radio (3), and reinstall any clips or fasteners (4) used in original installation.

4. Using twine attached to antenna assembly, lower assembly through antenna hole in fender low enough to install wedge (5) from original antenna. Install new rubber gasket (6) on billet base (7) and thread twine through base allowing it to sit over antenna hole where original base was seated. Pull twine or line until antenna assembly comes up through fender hole. Make sure wedge is properly clocked and seated on antenna assembly and in fender hole.

5. Thread new billet antenna nut (8) over base onto antenna body. Make sure locating notch on base is installed over tab on wedge. There are a few degrees of adjustment built into base to allow for variances in antenna hole slot location.

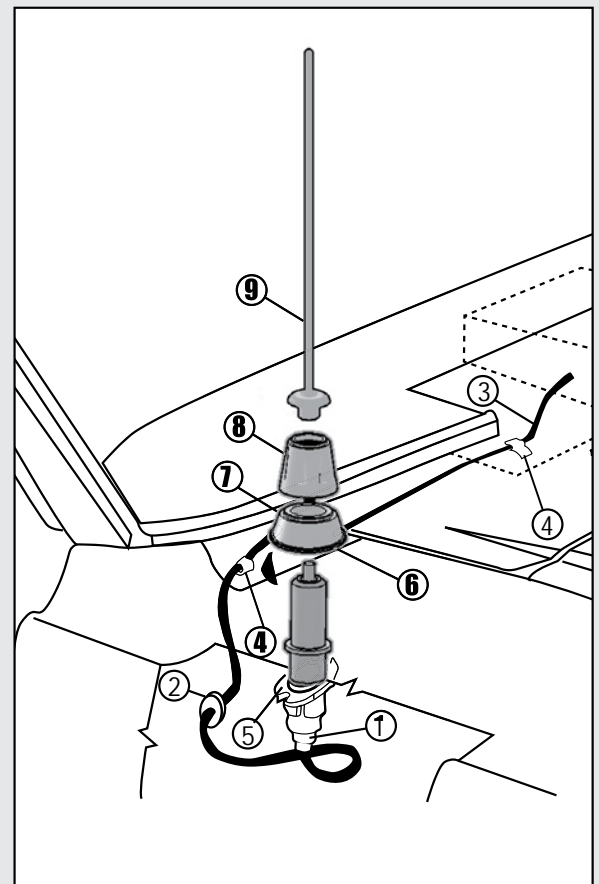

6. Remove string and thread cap from antenna assembly and finish tightening antenna nut until tight against fender.

7. Thread antenna mast (9) onto antenna assembly. Using pliers and a thick rag, strap wrench, or other suitable non marring means, tighten mast securely.

Also available from Scott Drake:



Also available from Scott Drake:

Bullet Style Mirrors



Sidewinder™ Billet Tail Light Bezels

