



Driven Beyond Perfection

# HEATER GASKET KIT INSTALLATION INSTRUCTIONS

C5ZZ-18500-A

APPLICATION: 64-66 Mustang

C7ZZ-18500-A

APPLICATION: 67-68 Mustang (without A/C)

## INSTALLATION

### Step 1:

The coolant system must be drained before removing the heater box. The box is held in place with 4 nuts at the firewall and 1 screw under the dash.

### Step 2:

After loosening the heater box from the firewall, remove the control cables from the box.

### Step 3:

After removing the heater box from the firewall, open the box by removing all clips holding the two halves together. Clean off the old foam seals from the inner doors and chamber box. For best results, sand blasting and painting all metal surfaces to prevent rust is recommended.

### Step 4:

Use a high quality spray adhesive. Spray the metal surface and one side of the foam seal. Let adhesive get tacky before installing.

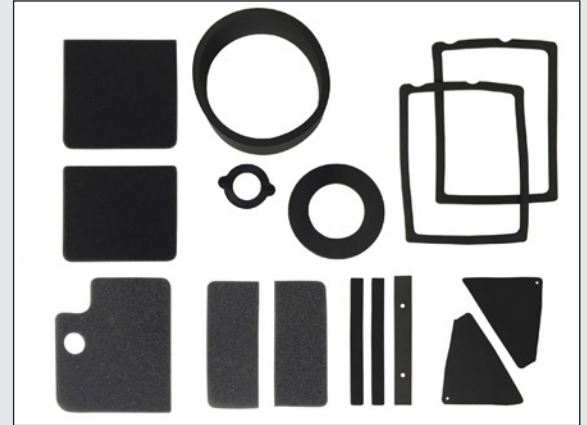

C5ZZ-18500-A

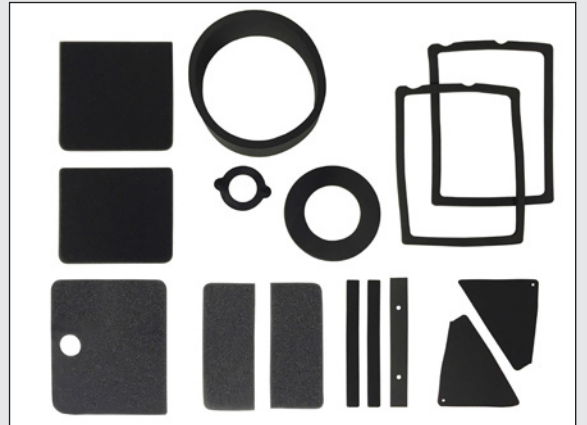

C7ZZ-18500-A

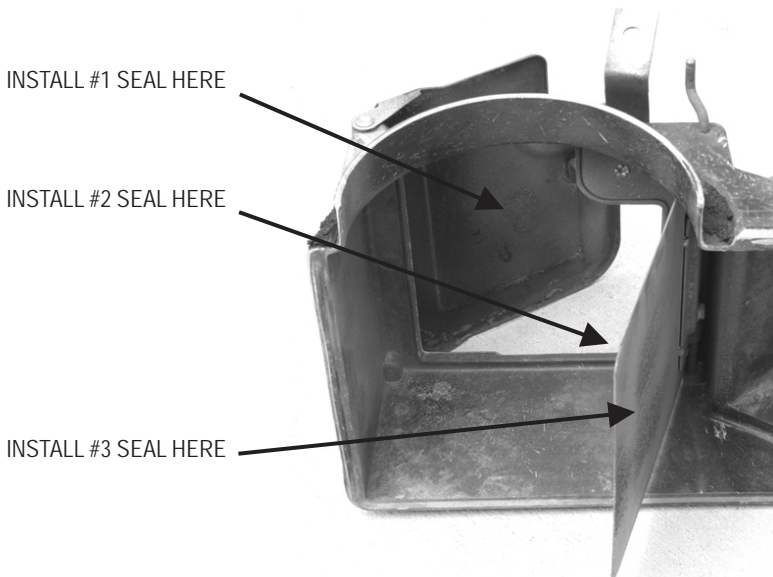

INSTALL #1 SEAL HERE

INSTALL #2 SEAL HERE

INSTALL #3 SEAL HERE

Heater box door assembly



64-66 Heater Box

C5ZZ-18500-A\_INST

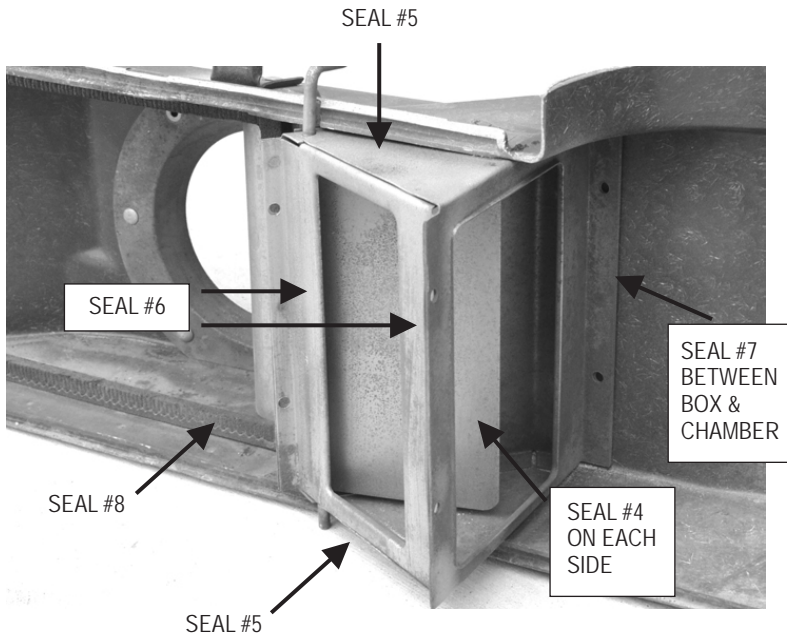

REMOVE BLOWER MOTOR & FAN.

SQUIRREL CAGE MUST BE REMOVED TO INSTALL SEAL #10

