

SCOSCHE[®]

**IN-DASH INSTALLATION KIT FOR
1982-2005 GENERAL
MOTORS VEHICLES**

**GM1504/
GM1504W**

QUICK START GUIDE

INTRODUCTION

The Scosche In-Dash Installation Kit for 1982-2002 General Motors Vehicles provides the parts you need to mount your aftermarket car stereo/CD player into your vehicle's dash. Refer to the individual instructions in this manual to remove your vehicle's factory installed radio.

SCOSCHE GM UNIVERSAL KITS

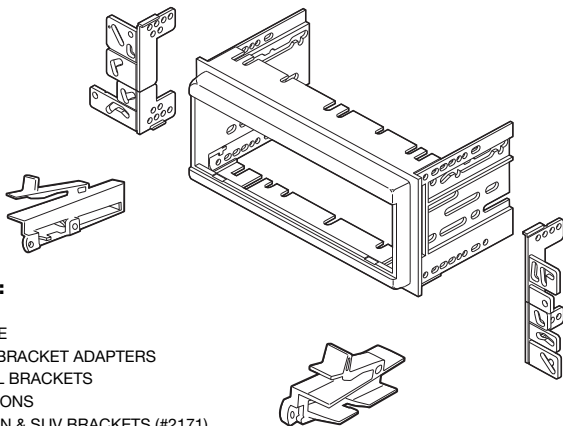

PARTS LIST:

- KIT PANEL
- HARDWARE
- FACTORY BRACKET ADAPTERS
- UNIVERSAL BRACKETS
- INSTRUCTIONS
- TRUCK, VAN & SUV BRACKETS (#2171)

QUICK START GUIDE

STEP 1 PICK YOUR VEHICLE

Locate your vehicle on the front cover of this instruction and disassemble the dash.

STEP 2 FACTORY RADIO?

Does your vehicle have the factory radio? If YES, proceed to next

STEP 3

If NO, go to

STEP 5

STEP 3 REMOVING FACTORY MOUNTING BRACKETS

If your original radio is secured to the dash with factory mounting bracket(s), use a 10mm socket wrench to remove the nut and the bracket(s) as shown.

NOTE: The factory radio may have brackets on the sides, top and/or bottom.

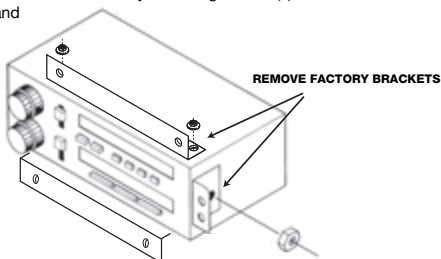

STEP 4 ASSEMBLY WITH FACTORY BRACKETS

TOP/BOTTOM:

Use the supplied carriage bolts and nuts to attach the factory mounting brackets directly to the kit panel as shown.

NOTE: If your bracket has small notches on it, they will have to be flattened out or filed off in order to mount the bracket to the top/bottom of the kit (see inset).

SIDES:

Attach the Factory Bracket Adapters FBA to left and right sides of the kit as shown. The FBA's locator pins should line up with the holes marked #1 on the sides of the kit panel. Be sure to insert a carriage bolt through the FBA facing outward through the square hole (see illustration). Repeat for both sides.

NOTE: Top and bottom factory brackets bolt directly to kit.

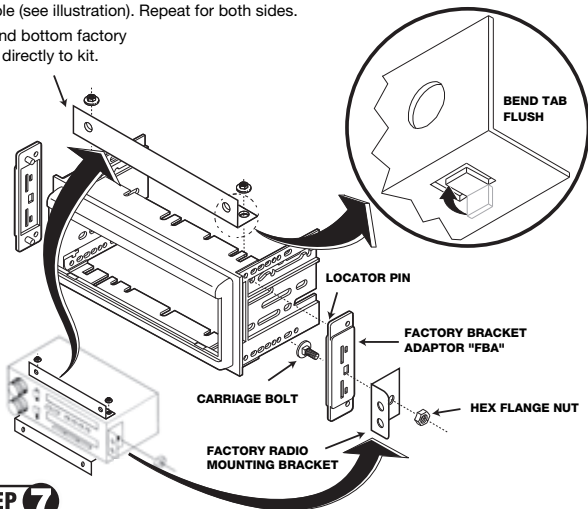

Go to

STEP 7

QUICK START GUIDE

STEP 5 ASSEMBLY WITH UNIVERSAL BRACKETS

ATTACHING THE SUPPLIED UNIVERSAL BRACKETS: (If no factory brackets are available)

The supplied mounting panel and brackets have numbered holes, and each bracket is labeled with a letter. Before you attach the brackets to the panel, locate the instructions for your vehicle in this manual. Each vehicle's instructions shows which brackets and holes to use for assembling the kit. After you identify the proper bracket and holes, mount them as shown in this section. Secure the specified bracket to the kit using the supplied cinch studs and nuts. Insert the cinch stud through the inside of the kit wall as shown.

Attach the brackets to the mounting panel using the cinch studs and nuts supplied with the kit as shown.

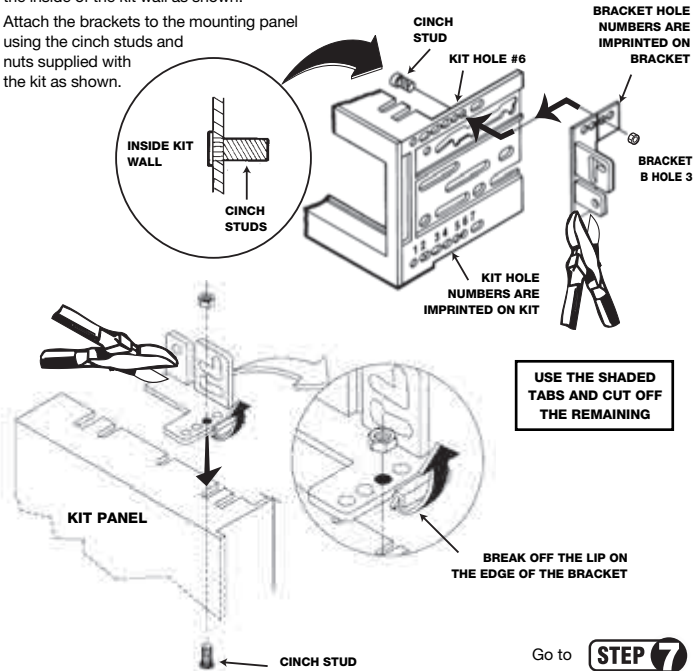

STEP 6 ASSEMBLY WITH TRUCK/SUV/VAN BRACKETS

Attach the Truck/SUV/Van brackets to the GM1504 side walls as shown using the cinch studs and nuts provided. Use two studs for each bracket in lower kit holes #2 and #8. Each bracket contains support pins which rest in kit holes #4 and #7.

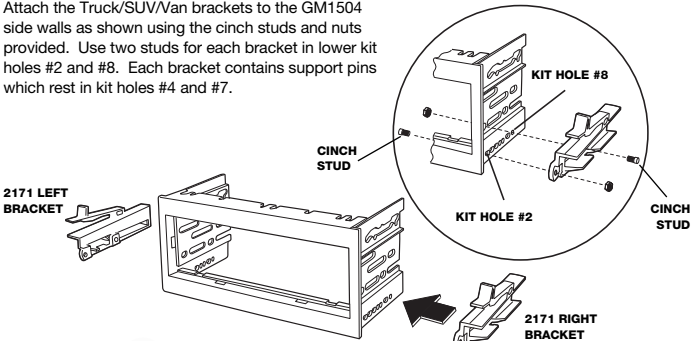

Go to **STEP 7**

QUICK START GUIDE

STEP 7 STEREO ASSEMBLY

NOTE: The mounting sleeve must be removed from the stereo first! Your stereo may be snapped into its sleeve. Slide the mounting sleeve (metal shroud) off the stereo towards the back.

REMOVE SLEEVE FROM STEREO

1. Locate the locking mechanism on your DIN stereo sleeve (typically) on the side.
2. Slip mounting sleeve towards rear of stereo and remove.

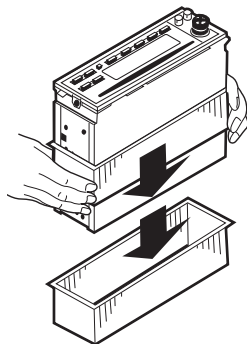

FLAT FACE DIN/DETACHABLE FACEPLATE/PULLOUT (DIN E) STEREO

Slide the mounting sleeve (metal shroud) into the panel's stereo opening and bend all available mounting tabs outward (see inset). Slide the stereo into the mounting sleeve once it has been fastened to the kit panel until the radio locks into place.

NOTE: REAR SUPPORT STRAPS NOT INCLUDED. REAR SUPPORTING THE STEREO ADDS TO THE INSTALLATION'S STRUCTURAL INTEGRITY.

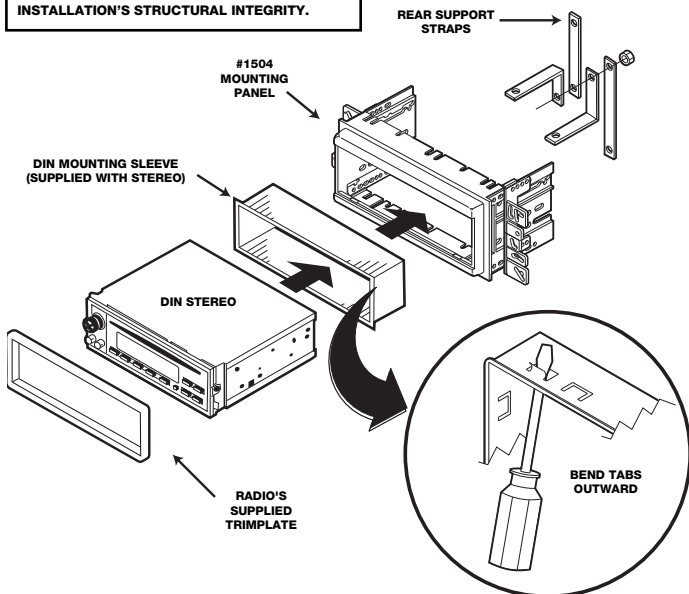

QUICK START GUIDE

STEP 8 STEREO CONNECTION*

USE THE APPROPRIATE SCOSCHE WIRING CONNECTOR (*not included)

Wire up your new aftermarket stereo to the Scosche wiring connector and install the Scosche kit and new stereo assembly in your vehicle. Follow the dash disassembly for your specific vehicle in reverse order to reassemble your dash.

FACTORY WIRING CODES

NOTE: All wire codes are viewed as looking at the front of the plug with the wires exiting the rear.

1978-87 GENERAL MOTORS

BLACK - POWER

- 1 = GROUND
- 2 = POWER
- 3 = LAMP
- 4 = POWER ANTENNA

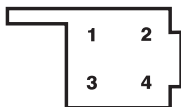

WHITE - FRONT SPEAKERS

- 1 = RF+, RIGHT FRONT POSITIVE
- 2 = R COMMON, RIGHT COMMON
- 3 = LF+, LEFT FRONT POSITIVE
- 4 = L COMMON, LEFT COMMON

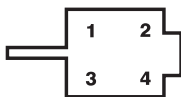

BLUE - REAR SPEAKERS

- 1 = LR+, LEFT REAR POSITIVE
- 2 = L COMMON, LEFT COMMON
- 3 = RR+, RIGHT REAR POSITIVE
- 4 = R COMMON, RIGHT COMMON

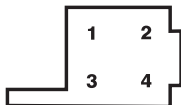

1988-UP GENERAL MOTORS

(Vehicles equipped with "mini-type" connectors)

BLACK - POWER

- 1 = GROUND
- 2 = DIMMER
- 3 = ILLUMINATION
- 4 = POWER ANTENNA
- 5 = +12V SWITCHED, IGNITION
- 6 = +12V CONSTANT, BATTERY



WHITE - FRONT SPEAKERS

- 1 = LF-, LEFT FRONT NEGATIVE
- 2 = LF+, LEFT FRONT POSITIVE
- 3 = RF-, RIGHT FRONT NEGATIVE
- 4 = RF+, RIGHT FRONT POSITIVE



BLUE - REAR SPEAKERS

- 1 = LR+, LEFT REAR POSITIVE
- 2 = LR-, LEFT REAR NEGATIVE
- 3 = RR+, RIGHT REAR POSITIVE
- 4 = RR-, RIGHT REAR NEGATIVE



1997-99 Pontiac Grand Prix

RADIO REMOVAL:

1. Extract two panel fasteners from driver's (left) side underdash cover.
2. Extract two 7mm hex screws from bottom edge of driver's (left) side lower dash panel and carefully pull out on the upper panel to release two panel clips. Unplug and remove the dash piece.
3. Carefully pull out on the complete dash/radio/instrument bezel, unplug, and unplug before removing.
4. Extract two 7mm screws holding the factory radio, unplug connectors and antenna to remove radio.

"A1" BRACKET USE HOLE #2

"A1" SOPORTE USA ABERTURA NO. 2

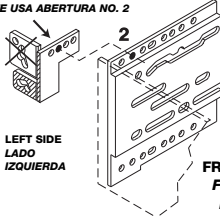

"B1" BRACKET USE HOLE #1

"B1" SOPORTE USA ABERTURA NO. 1

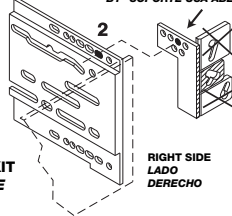

USE THE SHADED BRACKETS & THE INDICATED HOLE LOCATIONS. CUT OFF THE REMAINING BRACKETS & DISCARD.
Usa los soportes asombrados y las localizaciones de aberturas indicadas. Corta los soportes que sobran y deséchalas.

1994-96 Pontiac Grand Prix

RADIO REMOVAL:

1. Remove ash tray.
2. Extract two push pin style fasteners on the bottom side of the radio/dash/bezel where it curves under the dash.
3. Carefully pry out on the dash trim to release two panel clips and remove the dash piece.
4. Extract two 7mm screws holding the factory radio, unplug connectors and antenna to remove radio.

"A1" BRACKET USE HOLE #2

"A1" SOPORTE USA ABERTURA NO. 2

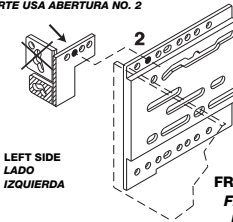

"B2" BRACKET USE HOLE #2

"B1" SOPORTE USA ABERTURA NO. 2

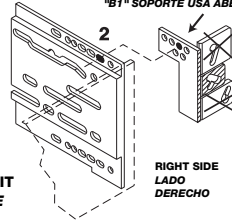

USE THE SHADED BRACKETS & THE INDICATED HOLE LOCATIONS. CUT OFF THE REMAINING BRACKETS & DISCARD.
Usa los soportes asombrados y las localizaciones de aberturas indicadas. Corta los soportes que sobran y deséchalas.

1992-1993 Pontiac Grand Prix

RADIO REMOVAL:

1. Extract the two screws securing the glove box door hinges and remove the door.
2. Extract the two screws securing the radio trim bezel on the passenger side.
3. Extract the three screws from the underside of the dash securing the under dash panel below the steering column. Disconnect all the connectors and remove the panel.
4. Extract the two screws securing the radio trim bezel on the driver's side and remove the bezel.
5. Remove the two nuts from the bottom of the radio cavity securing the radio to the dash. Pull the radio from the cavity, unplug the connectors and remove the radio.

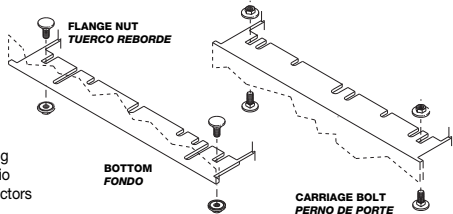

USE THE SUPPLIED CARRIAGE BOLTS & NUTS TO MOUNT THE KIT PANEL TO THE SUB-DASH.
Usa los pernos de portey tuercos proveidos para montar la tablero estuche al tablero-sub.

1995-99 Pontiac Sunfire/Convertible

RADIO REMOVAL:

1. Open glovebox then remove two screws along the right side of the radio/heater trim bezel.
2. Carefully pull out on the right side of the radio/heater trim bezel and two alignment pins will release on the driver's steering column panel.
3. Remove radio/heater trim bezel.
4. Extract two screws holding radio, unplug and remove.

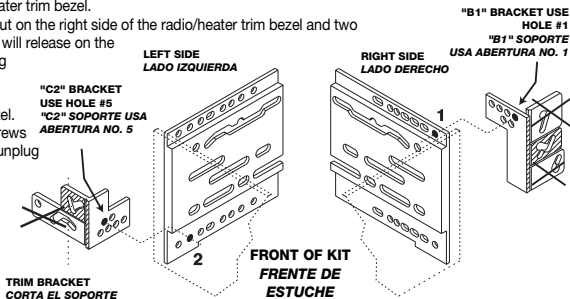

USE THE SHADED BRACKETS & THE INDICATED HOLE LOCATIONS. CUT OFF THE REMAINING BRACKETS & DISCARD.
 Usa los soportes asombrados y las localizaciones de aberturas indicadas. Corta los soportes que sobran y deséchalos.

1982-91 Pontiac 6000

RADIO REMOVAL:

1. Loosen the screw securing the radio trim panel to the left side of the glove box.
2. Carefully pull the panel outward to relieve the clips retaining the left side of the panel. Remove the trim panel.
3. Remove the four screws retaining the radio, and pull the radio out of the cavity.
4. Disconnect the antenna, speaker leads and all the electrical connections, then remove the radio.

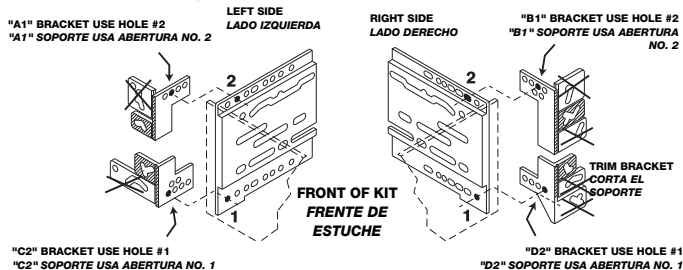

USE THE SHADED BRACKETS & THE INDICATED HOLE LOCATIONS. CUT OFF THE REMAINING BRACKETS & DISCARD.
 Usa los soportes asombrados y las localizaciones de aberturas indicadas. Corta los soportes que sobran y deséchalos.

1991-94 Saturn SC, SL, SL1, SL2

RADIO REMOVAL:

1. Using a panel removal tool/screwdriver, carefully pry outward on the dash bezel to release the clips and remove the bezel.
2. Extract the two screws securing the radio to the dash. Pull the unit out of the dash, unplug the connectors and remove the radio.

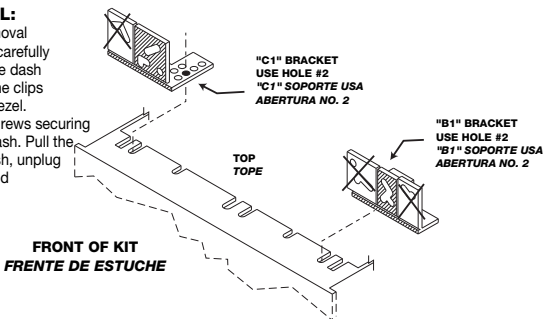

USE THE SHADED BRACKETS & THE INDICATED HOLE LOCATIONS. CUT OFF THE REMAINING BRACKETS & DISCARD.
 Usa los soportes asombrados y las localizaciones de aberturas indicadas. Corta los soportes que sobran y deséchalos.

1982-1996 Buick Century

RADIO REMOVAL:

1. Remove the four screws from under the top edge of the instrument cluster trim piece.
2. Remove the three screws and the two 7mm hex screws from below the instrument cluster trim piece.
3. Remove the three screws and the rocker-switch trim to the right of the instrument cluster. Pull firmly to remove the rocker-switch trim.

NOTE: For cars equipped with a column mounted shift lever, position the lever in low gear for additional clearance.

4. Remove the instrument cluster trim piece.
5. Remove the four screws from the radio brackets, pull the radio out of the cavity, then disconnect the antenna, speaker leads and all the electrical connections. Remove the radio.

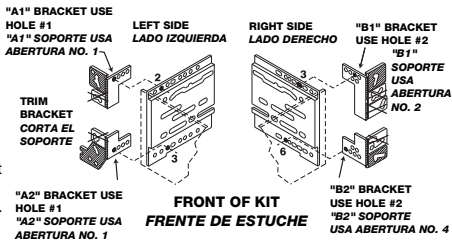

USE THE SHADED BRACKETS & THE INDICATED HOLE LOCATIONS. CUT OFF THE REMAINING BRACKETS & DISCARD.
Usa los soportes asombrados y las localizaciones de aberturas indicadas. Corta los soportes que sobran y deséchalas.

1985-90 Buick Electra/Park Avenue

1986-91 Buick Le Sabre

RADIO REMOVAL:

1. Carefully snap off the trim from around the air-conditioning controls.
2. Remove the four screws from behind the trim piece.
3. Slide the radio trim panel to the left (driver's side) of the car and remove it.

4. Remove the four screws which secure the radio to the dashboard, slide the radio out of the cavity and disconnect the antenna, speaker leads and all the electrical supply harnesses. Remove the radio.

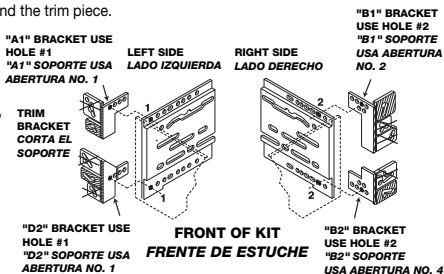

USE THE SHADED BRACKETS & THE INDICATED HOLE LOCATIONS. CUT OFF THE REMAINING BRACKETS & DISCARD.
Usa los soportes asombrados y las localizaciones de aberturas indicadas. Corta los soportes que sobran y deséchalas.

1984-87 Buick Regal

RADIO REMOVAL:

1. Remove the radio trim panel by carefully prying outward evenly around the edges.
2. Remove the four screws securing the radio mounting bracket to the dash. Pull the assembly out of the cavity to gain access to the wiring.
3. Disconnect the antenna and all the electrical connections, then remove the radio.

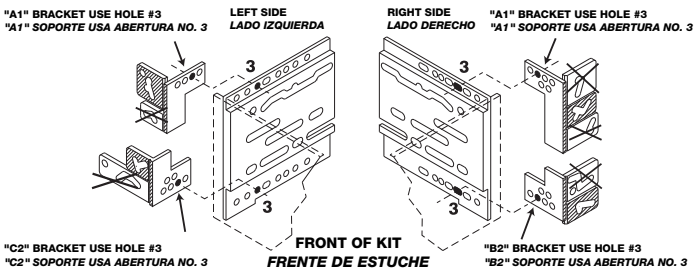

USE THE SHADED BRACKETS & THE INDICATED HOLE LOCATIONS. CUT OFF THE REMAINING BRACKETS & DISCARD.
Usa los soportes asombrados y las localizaciones de aberturas indicadas. Corta los soportes que sobran y deséchalas.

1992-94 Buick Le Sabre 1991-94 Buick Park Avenue

RADIO REMOVAL:

1. Extract the two screws from the top underside of the instrument trim bezel.
2. Remove the trim below the dash bezel on the left and right sides of the steering wheel by carefully prying outward with a panel removal tool/screwdriver to release the fastening clips.
3. Remove the eight screws located behind the trim securing the dash trim bezel and the lower section of the glove box.

4. Remove all four dash vents by pulling them outward and removing the single screw in each.

5. Open the glove box and extract the screws from each top corner and remove the glove box.

6. Remove the dash trim bezel.

7. Extract the five screws securing the radio, unplug all the connectors and remove the radio.

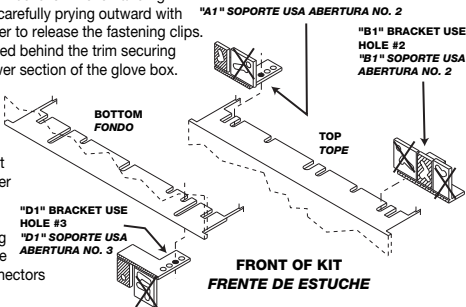

USE THE SHADED BRACKETS & THE INDICATED HOLE LOCATIONS. CUT OFF THE REMAINING BRACKETS & DISCARD.
Usa los soportes asombrados y las localizaciones de aberturas indicadas. Corta los soportes que sobran y desechalas.

1995-99 Buick Riviera

RADIO REMOVAL:

1. Gently pull outward on left and right windshield pillar panels to release (2) snap clips and extract each one.
2. Unsnap side dash panels and remove (1) 7mm screw from behind each.
3. Extract (6) plastic push-pin fasteners from under front edge of upper dash pad. Pull outward to remove the bottom panel of the upper dash pad.
4. Extract (5) 7mm screws securing upper dash pad, lift up and outward to remove pad.
5. Carefully pull outward on dash/instrument bezel to release clips, unplug and remove bezel.
6. Extract (3) 7mm screws from climate control module, unplug and remove module.
7. Extract (4) 7mm screws securing radio, unplug connectors, antenna lead, and remove radio.

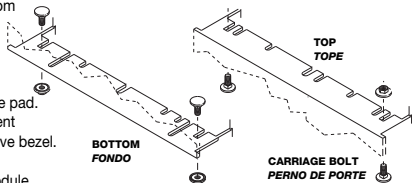

USE THE SUPPLIED CARRIAGE BOLTS & NUTS TO MOUNT THE FACTORY BRACKET TO THE KIT.
Usa los pernos de porte y tuercos proveídos para ensamblar la abrazadera de fábrica al kit.

1991-94 Buick Roadmaster 1991-93 Chevrolet Caprice/Caprice Classic

RADIO REMOVAL:

1. Remove the two screws from along the bottom of the dash which secure the service panel (driver's side). Pull down on the panel to release the four clips and remove the panel.
2. Carefully pry off the trim piece from above the glove box. Remove the screw located behind the trim location.
3. Remove the three screws from the dash bezel (underside of dash pad).
4. Remove one screw from the lower left inside corner of the glove box.
5. Remove one screw from the parking brake release cavity.
6. Work around the perimeter of the dash bezel and release all the spring clips. Tilt the steering wheel down, place the shifter into low and remove the dash bezel.
7. Remove the three screws securing the radio, disconnect the connectors and remove the radio.

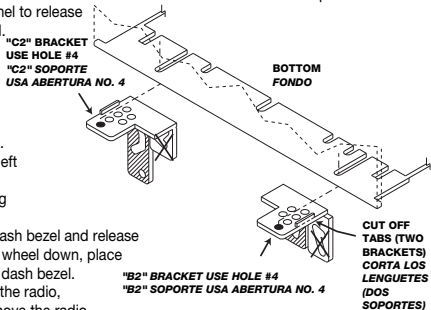

USE THE SHADED BRACKETS & THE INDICATED HOLE LOCATIONS. CUT OFF THE REMAINING BRACKETS & DISCARD.
Usa los soportes asombrados y las localizaciones de aberturas indicadas. Corta los soportes que sobran y desechalas.

1982-89 Buick Skyhawk 1982-88 Oldsmobile Firenza

RADIO REMOVAL:

1. Disconnect the support strap from the glove box door.
2. Remove the four screws securing the glove box liner.
3. Pull the glove box liner outward and remove it.
4. Remove the two screws from below the lighter/heater controls.
5. Remove the three screws securing the lower dash panel (each side of the steering column).
6. Pull the panel down to expose the screw under the panel, and to the left of the heater control. Unsnap the panel assembly and remove it.
7. Remove the four screws securing the radio to the dash; pull the radio out of the dash cavity.
8. Disconnect the antenna and all the electrical connections, then remove the radio.

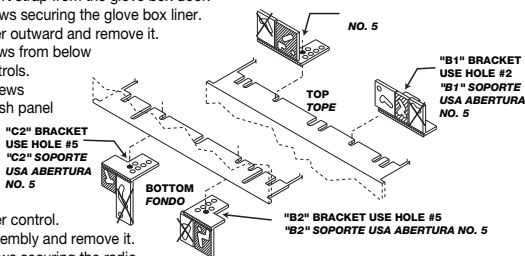

USE THE SHADED BRACKETS & THE INDICATED HOLE LOCATIONS. CUT OFF THE REMAINING BRACKETS & DISCARD.
Usa los soportes asombrados y las localizaciones de aberturas indicadas. Corta los soportes que sobran y desechalas.

1992-95 Buick Skylark

RADIO REMOVAL:

1. Pull out on the ashtray and extract the two screws securing the rear of the ashtray assembly.
2. Extract the two screws securing the front of the ashtray and the lower section of the radio trim bezel in the ashtray cavity.
3. Carefully pry outward on the radio trim bezel with a panel removal tool/screwdriver to release the fastening clips securing it to the dash and remove.
4. Remove the two nuts from the bottom of the radio chassis securing the radio to the dash. Pull the radio from the cavity, unplug all the connectors, and remove the radio.

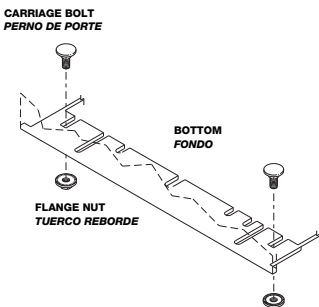

USE THE SHADED BRACKETS & THE INDICATED HOLE LOCATIONS. CUT OFF THE REMAINING BRACKETS & DISCARD.
Usa los soportes asombrados y las localizaciones de aberturas indicadas. Corta los soportes que sobran y desechalas.

1983-85 Buick Skylark

RADIO REMOVAL:

1. Remove the four 9/32 inch hex head screws from the top of the instrument cluster trim panel. Remove one hex head sheet metal screw from the bottom left of the instrument cluster trim panel.
2. Remove the two 7mm hex head sheet metal screws from the trim below the steering column and remove the trim.
3. Place the ignition in the "on" position, apply the emergency brake and put the transmission in second gear. Carefully remove the trim panel from the dash and around the steering column.
4. Remove the four 7mm hex head sheet metal screws from the radio mounting brackets. Slide the radio out of the cavity. Disconnect all the wiring and remove the radio.

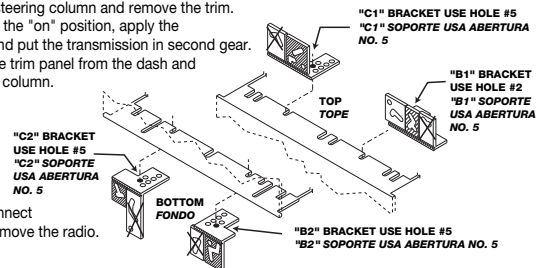

USE THE SHADED BRACKETS & THE INDICATED HOLE LOCATIONS. CUT OFF THE REMAINING BRACKETS & DISCARD.
Usa los soportes asombrados y las localizaciones de aberturas indicadas. Corta los soportes que sobran y desechalas.

1982-88 Cadillac Cimarron
1982-90 Chevrolet Cavalier "VL"
or Base Models
1982-88 Pontiac Sunbird/J-2000

RADIO REMOVAL:

1. Remove the six screws from the dash trim panel.
2. Release the panel at the top first, then carefully at the bottom and remove the trim panel.

NOTE: For column mounted gear selectors, place the gear selector in low gear to provide additional clearance.

3. Remove the two screws from the top of the factory radio retainer bracket.
4. Carefully pull the radio out of the cavity, then disconnect the antenna, speakers and all the electrical connections. Remove the radio.

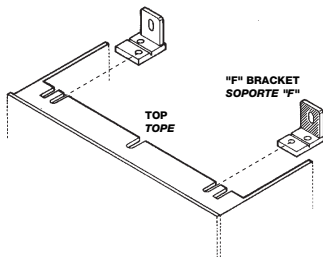

USE THE SHADED BRACKETS & THE INDICATED HOLE LOCATIONS. CUT OFF THE REMAINING BRACKETS & DISCARD.
Usa los soportes asombrados y las localizaciones de aberturas indicadas. Corta los soportes que sobran y deséchalas.

1992-95 Cadillac DeVille

RADIO REMOVAL:

NOTE: The following information is for the non-Bose stereo equipped vehicle.

1. Carefully pull out on the radio perimeter trim bezel.
2. Push the two tabs in on the sides of the factory stereo. One on the upper left side and one on the lower right side.
3. Slide the radio out, unplug and remove the radio.

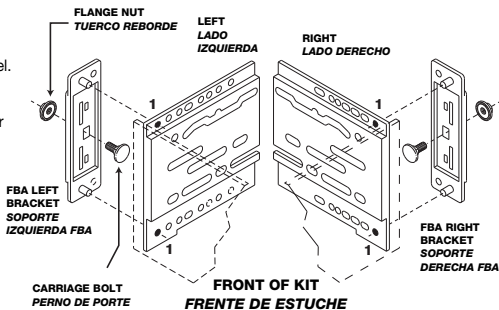

USE THE SHADED BRACKETS & THE INDICATED HOLE LOCATIONS. CUT OFF THE REMAINING BRACKETS & DISCARD.
Usa los soportes asombrados y las localizaciones de aberturas indicadas. Corta los soportes que sobran y deséchalas.

1985-91 Cadillac DeVille
1985-92 Cadillac Fleetwood

RADIO REMOVAL:

1. Remove (2) Phillips head sheet metal screws from top edge of the radio trim panel. Remove the trim panel.
2. Remove (2) 7mm hex head bolts from the top radio mounting bracket.
3. Open ashtray and remove (1) 7mm hex head screw (farthest towards rear of car on driver's side).
4. Slide the radio out of cavity, disconnect all wiring, and remove radio.

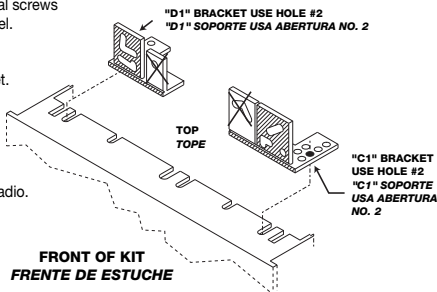

USE THE SHADED BRACKETS & THE INDICATED HOLE LOCATIONS. CUT OFF THE REMAINING BRACKETS & DISCARD.
Usa los soportes asombrados y las localizaciones de aberturas indicadas. Corta los soportes que sobran y deséchalas.

1986-91 Cadillac Eldorado

1986-91 Cadillac Seville

RADIO REMOVAL:

1. Gently pry on the edges of the vent trim piece located above the radio. Release the snaps and remove the trim piece.
2. Remove the three screws from above the radio.
3. Extract the three screws from the dash panel trim piece above the instrument cluster.
4. Gently pry out the driver's side air vent in the dash trim to access the single screw which secures the left side of the trim panel. Remove the screw and the trim panel.
5. Loosen the two bolts which secure the radio to the dash. Slide the radio out of the cavity. Disconnect the antenna, speakers, all the electrical connections and remove the radio.

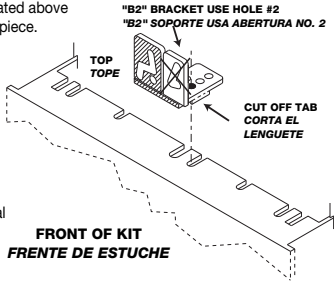

USE THE SHADED BRACKETS & THE INDICATED HOLE LOCATIONS. CUT OFF THE REMAINING BRACKETS & DISCARD.
Usa los soportes asombrados y las localizaciones de aberturas indicadas. Corta los soportes que sobran y deséchalas.

1984-85 Cadillac Eldorado

1984-85 Cadillac Seville

RADIO REMOVAL:

1. Remove the two screws from the top of the radio trim panel and remove the trim panel.
2. Remove the two screws securing the radio bracket to the dash, then pull the radio out of the cavity.
3. Disconnect the antenna, speakers and all the electrical connections, then remove the radio.

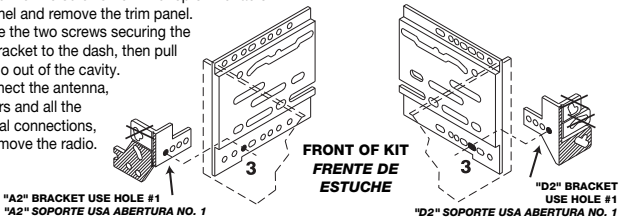

USE THE SHADED BRACKETS & THE INDICATED HOLE LOCATIONS. CUT OFF THE REMAINING BRACKETS & DISCARD.
Usa los soportes asombrados y las localizaciones de aberturas indicadas. Corta los soportes que sobran y deséchalas.

2002 Cadillac Escalade EXT

1999-02 Cadillac Escalade

2001-02 Chevrolet Avalanche

1995-99 Chevrolet Crew Cab Dually Pickup

1995-02 Chevrolet Pickup - Full Size

1995-02 Chevrolet Suburban

1995-02 GMC Pickup - Full Size

1995-02 Chevrolet Tahoe

1995-01 GMC Suburban

1995-00 GMC Crew Cab

2002 GMC Yukon XL

Dually Pickup

1995-02 GMC Yukon

RADIO REMOVAL:

1. Engage parking brake.
2. Place key in ignition and depress brake to shift vehicle into lowest gear. This will allow the gear shift to be out of the way.
3. Carefully pull out on dash instrument / radio dash bezel to release spring clips, unplug connectors and remove panel.
4. Compress the two plastic side radio mounting clips, slide radio out of dash, unplug connectors and remove radio.

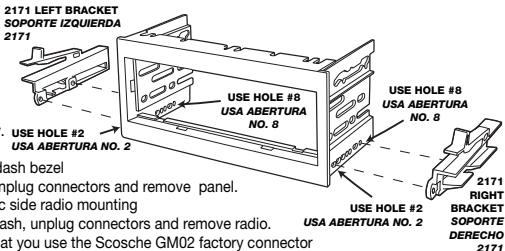

NOTE: We recommended that you use the Scosche GM02 factory connector and the MDA-1 antenna adapter to eliminate the need to cut any of the factory plugs.

USE THE INDICATED BRACKETS AND HOLE LOCATIONS. SEE PAGE 4.
Usa los soportes y localizaciones de aberturas indicadas. Vea la página 4.

1996-02 Chevrolet Astro Van

1996-02 GMC Safari Van

RADIO REMOVAL:

1. Extract (2) T-30 Torx bolts, one from each side of the top console area and pop out top half of center console assembly.
2. Extract (2) 9/32" hex screws from the bottom edge of the driver's side under dash panel and (1) screw from left dash below defroster vent.
3. Carefully pry underdash panel out to release, and use caution when handling parking brake release cable to release spring clips, unplug connectors and remove panel.
4. Insert key into "on", adjust shifter down (low gear), pull outward on the instrument/radio panel to release clips, unplug switches & remove panel.
5. Push down on side tabs securing radio, slide out of dash, unplug & remove radio.

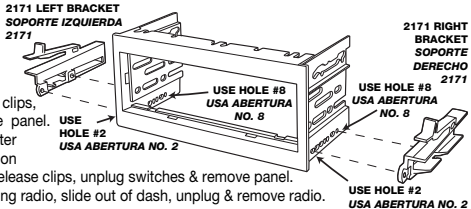

USE THE INDICATED BRACKETS AND HOLE LOCATIONS. SEE PAGE 4.
Usa los soportes y localizaciones de aberturas indicadas. Vea la página 4.

1990-95 Chevrolet Astro

1990-95 GMC Safari

RADIO REMOVAL:

1. Remove two screws from the underside of the center dash trim piece.
2. Carefully release the spring clips securing the center panel trim piece (trim snaps off).
3. Pull the trim away from the dash, disconnect the various electrical connections, and remove the panel.
4. Extract the four screws securing the radio to the dash, two screws at each side, pull the radio out of the cavity, and disconnect the antenna and electrical harnesses. Remove the radio.

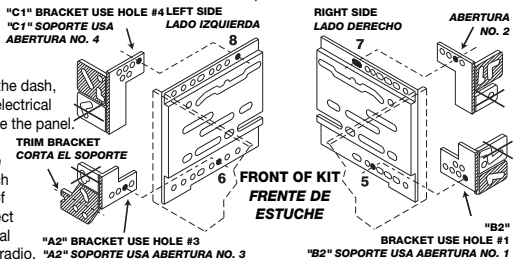

USE THE SHADED BRACKETS & THE INDICATED HOLE LOCATIONS. CUT OFF THE REMAINING BRACKETS & DISCARD.
Usa los soportes asombrados y las localizaciones de aberturas indicadas. Corta los soportes que sobran y deséchalas.

1985-89 Chevrolet Astro

1985-89 GMC Safari

RADIO REMOVAL:

1. Remove three screws from the top edge of the radio trim panel.
2. Remove two 10mm bolts from the lower edge of the trim panel (inside glove box).
3. Pull the console trim towards the rear of the vehicle and remove two 7mm bolts from behind the trim. Remove the radio trim panel.
4. Remove two screws from the bottom of the radio retainer bracket.
5. Carefully pull the radio out of the cavity. Disconnect the antenna, speaker and all electrical connections, then remove the radio.

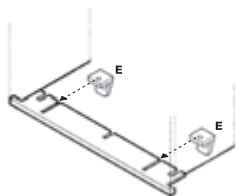

USE THE "E" BRACKETS ON THE BOTTOM LEFT AND BOTTOM RIGHT SIDE OF THE KIT.
Usa los soportes "E" abajo en los lados izquierda y derecha del estuche.

1991-96 Chevrolet Beretta

1991-96 Chevrolet Corsica

RADIO REMOVAL:

1. Remove the radio trim bezel by prying outward with a panel removal tool/screwdriver releasing the snap clips securing it to the dash.
2. Extract two screws securing the radio to the dash. Pull the radio out of the cavity, unplug all connectors and remove the radio.

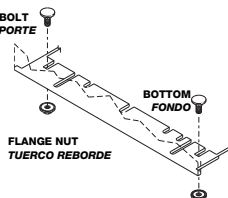

USE THE SHADED BRACKETS & THE INDICATED HOLE LOCATIONS. CUT OFF THE REMAINING BRACKETS & DISCARD.
Usa los soportes asombrados y las localizaciones de aberturas indicadas. Corta los soportes que sobran y deséchalas.

1989-91 Chevrolet Blazer/Jimmy-Full Size

1989-91 Chevrolet/GMC Suburban

1989-91 Chevrolet/GMC Crew-Cab Dually Pickup

RADIO REMOVAL:

1. Remove the eight screws securing the instrument/radio trim panel.
2. Extract the four screws from the steering column bottom trim piece, two on each side of the column.
3. Place the gear selector in low (one) gear to provide additional clearance, then remove the instrument radio trim panel from the dash.
4. Extract the two bolts securing the face of the radio; then, from below the dash, remove the rear support bolt from the bottom of the dash sheet metal.
5. Pull the radio out of the dash cavity, disconnect the radio harnesses and antenna, then remove the radio.

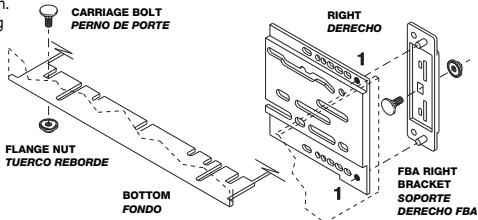

USE THE SHADED BRACKETS & THE INDICATED HOLE LOCATIONS. CUT OFF THE REMAINING BRACKETS & DISCARD.
Usa los soportes asombrados y las localizaciones de aberturas indicadas. Corta los soportes que sobran y deséchalas.

1997-02 Chevrolet Camaro

RADIO REMOVAL:

1. Carefully pry out on the dash trim bezel to release the fastening clips, unplug all switches and remove the bezel.
2. Extract two screws securing the radio, unplug and remove.

"A1" BRACKET USE HOLE #2
"A1" SOPORTE USA
ABERTURA NO. 2

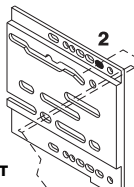
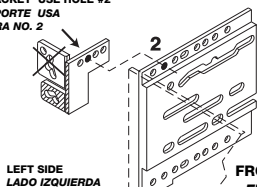

"B1" BRACKET
USE HOLE #2
"B1" SOPORTE USA
ABERTURA NO. 2



USE THE SHADED BRACKETS & THE INDICATED HOLE LOCATIONS. CUT OFF THE REMAINING BRACKETS & DISCARD.
Usa los soportes asombrados y las localizaciones de aberturas indicadas. Corta los soportes que sobran y deséchalas.

1993-96 Chevrolet Camaro

RADIO REMOVAL:

1. Extract three screws from the bottom edge of the dash below the glove box and remove the glove box.
2. Extract three screws in the glove box cavity that secure the radio trim bezel to the dash.
3. Extract two screws from the center of the under dash panel below the steering column.
4. Extract two screws at the bottom edge of the dash below the steering column and remove the underdash panel.
5. Extract two screws from where you removed the under dash panel to remove the radio trim bezel.
6. Extract two screws securing the radio to the dash on the drivers side and the 10mm bolt securing the radio on the passenger side.

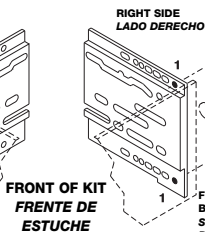
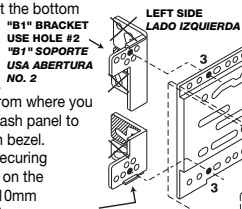

USE THE SHADED BRACKETS & THE INDICATED HOLE LOCATIONS. CUT OFF THE REMAINING BRACKETS & DISCARD.
Usa los soportes asombrados y las localizaciones de aberturas indicadas. Corta los soportes que sobran y deséchalas.

1982-92 Chevrolet Camaro

1982-84 Pontiac Firebird

RADIO REMOVAL:

1. Remove the four screws from the radio trim panel.
2. Pull the panel up and outward towards the right.
3. Remove the four screws from the radio bracket, pull the radio out of the cavity. Disconnect the antenna, speaker and all the electrical connections, then remove the radio.

NOTE: During the installation procedure the right side of the console must be pushed out 1/2 inch to accommodate some units. Loosen the right side of, or remove the factory rear support bar.

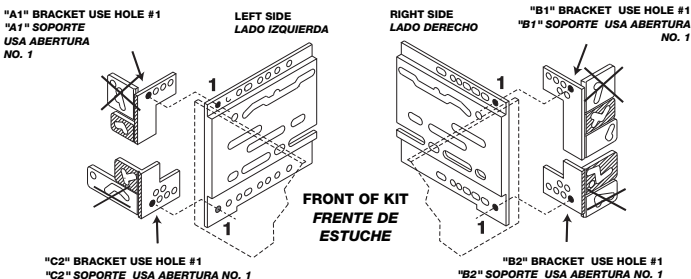

USE THE SHADED BRACKETS & THE INDICATED HOLE LOCATIONS. CUT OFF THE REMAINING BRACKETS & DISCARD.
Usa los soportes asombrados y las localizaciones de aberturas indicadas. Corta los soportes que sobran y deséchalas.

1994-96 Chevrolet Caprice Classic

1994-96 Chevrolet Impala SS

RADIO REMOVAL:

1. Remove the fuse panel on the left side of the dash.
2. Extract one 9/32 inch screw behind the fuse panel.
3. Extract the two 9/32 inch screws from the under the dash panel on the driver's side (not the black wiring access panel).
4. Extract the two 9/32 inch screws from below the ash tray.
5. Extract the two 9/32 inch screws from the top of the instrument panel bezel.
6. Make sure the parking brake is on, then insert the key and turn to the "on" position.
7. Put the vehicle into first or low gear, and tilt the steering column adjustment all the way down and pull outward on the instrument panel bezel. There are two spring clips on the bottom, release and remove the spring clips.
8. Extract the four 9/32 inch screws holding the ash tray, remove the ash tray, unplug the connector for the light.
9. Open the glove box.
10. Starting from the left side of the dash, working below the steering column, pull gently outward to start releasing the spring clips.
11. Work all the way across the dash piece, there are about eight spring clips total. The last one will pop out near the glove box. Remove the dash.
12. Extract the two 9/32 inch screws holding the radio, slide the radio out.
13. Unplug all the connectors and the antenna and remove the radio.

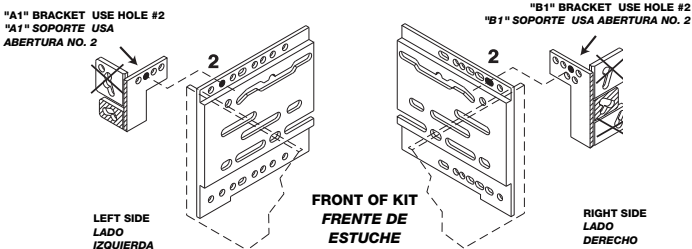

USE THE SHADED BRACKETS & THE INDICATED HOLE LOCATIONS. CUT OFF THE REMAINING BRACKETS & DISCARD.
Usa los soportes asombrados y las localizaciones de aberturas indicadas. Corta los soportes que sobran y deséchalas.

1995-99 Chevrolet Cavalier

RADIO REMOVAL:

1. Extract one screw from the front center defroster vent on top of the dashboard.
2. Using a panel removal tool carefully snap out the vent and remove it.
3. Extract one 7mm hex head screw from under defrost vent.
4. Using a panel removal tool remove the left dash side panel surrounding the fuse block opening and remove one 7mm screw from that location.
5. Using a panel removal tool release the panel at the right side of the dash and remove one 7mm screw behind.
6. Open glove box, extract three screws holding the front edge of the dash panel.
7. Extract two brass 7mm screws from access hole in the roof of glove box securing metal bracket.
8. Carefully release fastening clips securing the top of the dash panel above the instrument cluster, lift the panel up and away to remove.

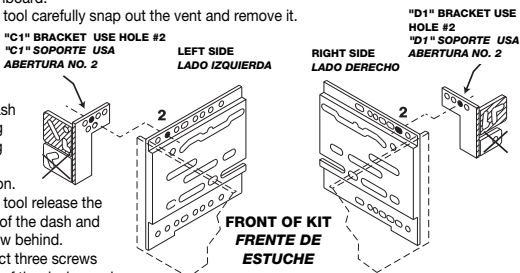

CAUTION! Passenger airbag cover is attached to the dash panel and will come off with the panel. USE EXTREME CARE WHEN WORKING AROUND THE INNER AIRBAG SKIN!

9. Extract three 7mm screws from the radio trim bezel and use a panel removal tool to release the snap clips around the radio and steering column.
10. Unplug bezel and remove.
11. Extract two screws holding radio in, unplug and remove radio.

USE THE SHADED BRACKETS & THE INDICATED HOLE LOCATIONS. CUT OFF THE REMAINING BRACKETS & DISCARD.
Usa los soportes asombrados y las localizaciones de aberturas indicadas. Corta los soportes que sobran y deséchalos.

1991-94 Chevrolet Cavalier

RADIO REMOVAL:

1. Using a panel removal tool/screwdriver, carefully remove the radio trim bezel by prying it outward to release the clips securing it to the dash.
2. Extract the two screws securing the radio to the dash. Pull the radio out of the cavity, unplug all the connectors and remove the radio.

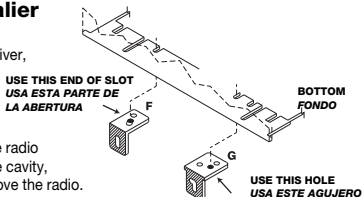

USE THE SUPPLIED CARRIAGE BOLTS & NUTS TO MOUNT THE FACTORY RADIO BRACKET ON THE BOTTOM OF THE KIT.
Usa los pernos de porte y tuercos para montar el soporte de radio de la fabrica en el fondo del estuche.

1985½-90 Chevrolet Cavalier RS, Z24

RADIO REMOVAL:

(All Z24 Models, RS Models through 1988)

1. Carefully pull outward on the console/radio trim panel. Spring clips are located along the top, middle and bottom of the panel.
2. Pull the panel away from the dash, disconnect the ashtray light and remove the panel.
3. Loosen two nuts along the bottom of the radio chassis.
4. Pull the radio out, disconnect the connectors and remove the radio.

RADIO REMOVAL:

(1989-90 RS Models)

1. Carefully pull outward on the console/radio trim panel. Spring clips are located along the top, middle and bottom of the panel.
2. Pull the panel away from the dash, disconnect the ashtray light and remove the panel.
3. Loosen two nuts along the bottom of the radio chassis.
4. Pull the radio out, disconnect the connectors and remove the radio.

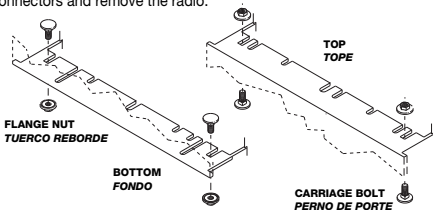

USE THE SUPPLIED CARRIAGE BOLTS & NUTS TO MOUNT THE FACTORY RADIO BRACKET ON THE TOP OF THE KIT.
Usa los pernos de porte y tuercos para montar el soporte de radio de la fabrica arriba del estuche.

1982-90 Chevrolet Celebrity

RADIO REMOVAL:

1. Open the glove box and slide the box towards the rear of the car.
2. Remove the five 1/2 inch nuts from the backside of the dash trim panel (directly above the glove box).
3. Release the locking clip from the headlight knob and remove the knob. Unscrew the plastic nut from behind the headlight knob and remove the nut.

4. Remove the ashtray and extract the three screws from the upper rear edge of the lower dash trim piece.
5. Unhook the cigarette lighter wiring. Unscrew the two-piece cigarette lighter (hold the rear piece behind the dash while unscrewing the front piece from the front side of the dash).

6. Remove the dash trim panel.

7. Remove the two screws from the right and one screw from the left of the radio, pull the radio out of the cavity. Disconnect the antenna, speaker and all the electrical connections, then remove the radio.

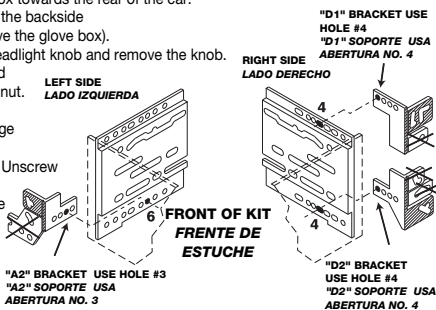

USE THE SHADED BRACKETS & THE INDICATED HOLE LOCATIONS. CUT OFF THE REMAINING BRACKETS & DISCARD.
Usa los soportes asombrados y las localizaciones de aberturas indicadas. Corta los soportes que sobran y deséchalos.

1985 Chevrolet Citation

RADIO REMOVAL:

1. Remove the two screws from the steering column trim panel.
2. Carefully pull the panel down and remove the two bolts which secure the bottom of the radio/instrument trim panel.

3. Remove the six screws from the dash trim panel.

4. Place the gear shift lever in the low position and pull the trim panel away from the dash.

5. Disconnect the wiring harnesses and remove the trim panel.

6. Remove the four bolts which secure the radio to the dashboard, pull the radio out of the cavity, disconnect the wiring harnesses and remove the radio.

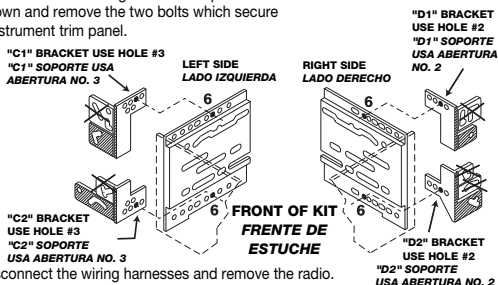

USE THE SHADED BRACKETS & THE INDICATED HOLE LOCATIONS. CUT OFF THE REMAINING BRACKETS & DISCARD.
Usa los soportes asombrados y las localizaciones de aberturas indicadas. Corta los soportes que sobran y deséchalos.

1984-89 Chevrolet Corvette

RADIO REMOVAL:

1. Remove the two screws above the A/C ducts (center console), and one screw on each side of the A/C controls.
2. Extract the two screws from between the right side of the dash console and the pad, then remove the single screw from the left side of the dash console.
3. Remove the dash console trim panel.
4. Remove the four screws from the radio brackets, pull the radio out of the cavity, disconnect the antenna, speaker leads and all the electrical connections, then remove the radio.

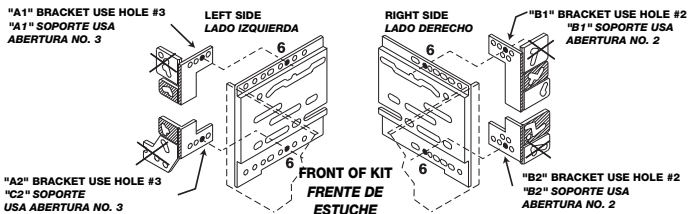

USE THE SHADED BRACKETS & THE INDICATED HOLE LOCATIONS. CUT OFF THE REMAINING BRACKETS & DISCARD.
Usa los soportes asombrados y las localizaciones de aberturas indicadas. Corta los soportes que sobran y deséchalos.

1996-00 Chevrolet Express Van

1996-00 GMC Savannah

RADIO REMOVAL:

- Carefully pull out on dash instrument/radio dash bezel to release spring clips, unplug connectors and remove panel.
- Compress the two plastic side radio mounting clips, slide radio out of dash, unplug connectors and remove radio.

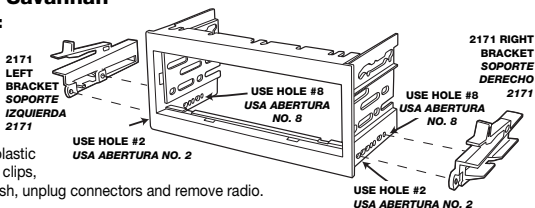

USE THE INDICATED BRACKETS AND HOLE LOCATIONS. SEE PAGE 4.
Usa los soportes y localizaciones de aberturas indicadas. Vea la página 4.

1995-99 Chevrolet Lumina

1995-99 Chevrolet Monte Carlo

RADIO REMOVAL:

- Remove the four T-15 TORX screws from the driver's lower knee bolster.
- Pull on the radio dash bezel to release the spring clips and remove.
- Extract the two 7 mm screws from the radio, unplug and remove the radio.

"C1" BRACKET USE HOLE #2
"C1" SOPORTE USA ABERTURA NO. 3

"D1" BRACKET USE HOLE #2
"D1" SOPORTE USA ABERTURA NO. 2

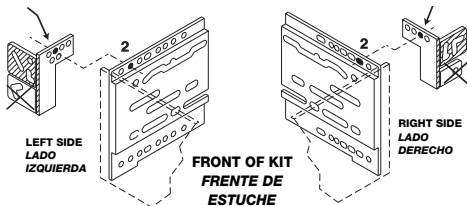

USE THE SHADED BRACKETS & THE INDICATED HOLE LOCATIONS. CUT OFF THE REMAINING BRACKETS & DISCARD.
Usa los soportes asombrados y las localizaciones de aberturas indicadas. Corta los soportes que sobran y deséchalas.

1990-94 Chevrolet Lumina

RADIO REMOVAL:

- Remove the two screws from the lower steering column trim piece (below the column). Pull the panel down to access the bottom portion of the dash trim.
- Pull outward along the top and bottom portion of the trim panel. Release each vent's individual spring clip.
- Extract the four screws from the radio bracket.
- Pull the unit out of the cavity. Disconnect the connectors and remove the unit.

NOTES: 1. Due to its rear support, you might need to use slight force to pull the radio free. 2. The factory antenna uses a micro-size jack. We recommend Radio Shack's GM antenna adaptor (Cat. number 12-1336).

"A1" BRACKET USE HOLE #2
"A1" SOPORTE USA ABERTURA NO. 2

LEFT SIDE LADO IZQUIERDA

RIGHT SIDE LADO DERECHO

"B1" BRACKET USE HOLE #3
"B1" SOPORTE USA ABERTURA NO. 3

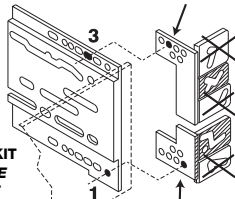
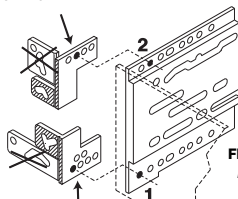

"C2" BRACKET USE HOLE #1
"C2" SOPORTE USA ABERTURA NO. 1

"B2" BRACKET USE HOLE #1
"B2" SOPORTE USA ABERTURA NO. 1

USE THE SHADED BRACKETS & THE INDICATED HOLE LOCATIONS. CUT OFF THE REMAINING BRACKETS & DISCARD.
Usa los soportes asombrados y las localizaciones de aberturas indicadas. Corta los soportes que sobran y deséchalas.

1994-96 Chevrolet Lumina APV

1994-96 Oldsmobile Silhouette

1994-96 Pontiac Trans Sport

RADIO REMOVAL:

1. Open the glove box door and remove the two Phillips-head screws at the right edge of the console.
2. Extract one 9/32 inch hex screw from the interior fan motor cover.
3. On the driver's side, extract the three 9/32 inch hex head screws just below the steering column, one above the hood release, one above the diagnostics plug, and one at the left side of the center console.
4. With the three screws extracted from the under dash cover there is one spring clip holding it, unsnap and remove the cover.
5. Release the four spring clips holding the panel along the bottom of the instrument cluster. Remove the panel.
6. Extract the four 10mm bolts holding the metal steering column access panel, remove the bolts.
7. Extract the two Phillips-head screws along the left edge of the console which become accessible from "step 6".
8. Slide the center console straight outward, unplug all the electrical connectors and remove.
9. Extract the two 10mm bolts underneath the front edge of the radio.
10. Extract the two T-15 Torx bolts above the front edge of the radio.
11. Slide the radio out of the dash, unplug all the connectors and the antenna. Remove the radio.

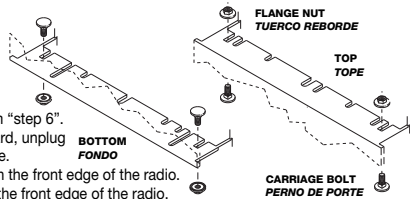

USE THE SUPPLIED CARRIAGE BOLTS & NUTS TO MOUNT THE KIT PANEL TO THE SUB-DASH.
Usa los pernos de portey tuercos proveidos para montar la tablera estuche al tablero-sub.

1990-93 Chevrolet Lumina APV

1990-93 Oldsmobile Silhouette

1990-93 Pontiac Trans Sport

RADIO REMOVAL:

1. Open the glove box to access the two screws on the right side that secure the radio trim.
2. From the driver's side remove the three screws from the belly trim piece: one at the hood release, one above the diagnostic connector and one at the lower backside of the console trim.
3. Release the spring clips from the top of the lower steering column trim piece and remove the trim.
4. Extract the two screws securing the left side of the radio trim and remove the trim.
5. Using a socket wrench, reach under the radio and remove the nut securing the bottom of the radio.
6. Extract two screws from the top radio bracket, pull the unit out, disconnect connectors & remove radio.

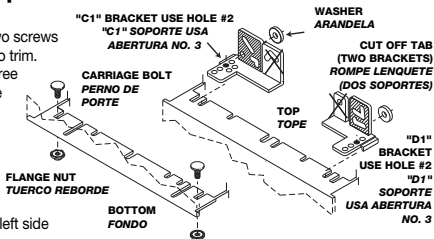

USE THE SUPPLIED CARRIAGE BOLTS & NUTS TO MOUNT THE KIT PANEL TO THE SUB-DASH.
Usa los pernos de portey tuercos proveidos para montar la tablera estuche al tablero-sub.

1997-00 Chevrolet Malibu

RADIO REMOVAL:

1. Carefully pop out plastic collar around ignition key and remove.
2. Carefully pop out radio trim, unplug lighter and remove.
3. Extract two 7mm screws holding radio in, unplug all connectors and remove radio.

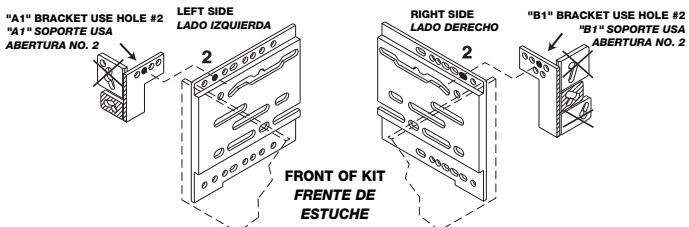

USE THE SHADED BRACKETS & THE INDICATED HOLE LOCATIONS. CUT OFF THE REMAINING BRACKETS & DISCARD.
Usa los soportes asombrados y las localizaciones de aberturas indicadas. Corta los soportes que sobran y desechalas.

1986-88 Chevrolet Monte Carlo

1986-87 Chevrolet El Camino

RADIO REMOVAL:

1. Remove the two screws from the top of the radio trim panel and the two screws from the bottom edge of the trim panel.
2. Remove the four screws which secure the radio, slide the radio out of the dash cavity and disconnect the wiring connectors.
3. Remove the radio.

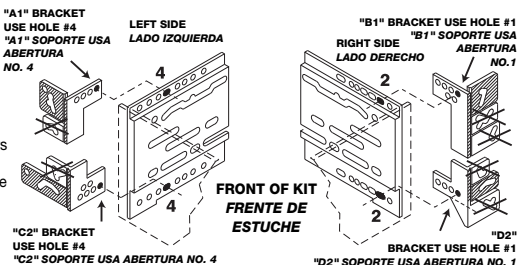

USE THE SHADED BRACKETS & THE INDICATED HOLE LOCATIONS. CUT OFF THE REMAINING BRACKETS & DISCARD.
Usa los soportes asombrados y las localizaciones de aberturas indicadas. Corta los soportes que sobran y deséchalas.

1985-88 Chevrolet Nova

RADIO REMOVAL:

1. Remove the ashtray and extract the two screws from the ashtray bracket. Then remove the bracket.
2. Extract the two screws from the top edge of the radio trim panel, pull the trim out and remove the panel.
3. Remove the four screws which secure the radio to the dash, slide the radio out of the dash cavity, disconnect the wiring harnesses and remove the radio.
4. Remove the two hex nuts from the factory radio mounting bracket, one from each side of the radio, and remove the bracket from the radio.

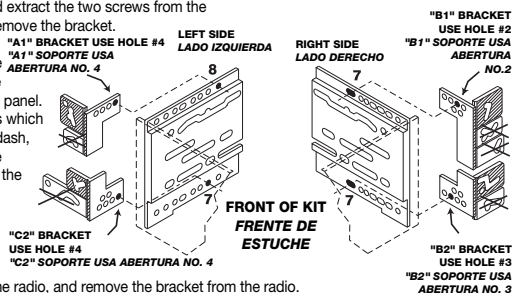

USE THE SHADED BRACKETS & THE INDICATED HOLE LOCATIONS. CUT OFF THE REMAINING BRACKETS & DISCARD.
Usa los soportes asombrados y las localizaciones de aberturas indicadas. Corta los soportes que sobran y deséchalas.

1998-01 Chevrolet S-10 Blazer

1998-01 Chevrolet S-10 Pickup

1998-01 GMC S-15 Jimmy

1998-01 GMC Sonoma Pickup

1998-00 Isuzu Hombre Pickup

RADIO REMOVAL:

1. Extract the (2) screws securing the top area of the driver's side underdash cover panel.
2. Pull the driver's side underdash down to access and extract (2) 7mm hex screws holding the bottom of the dash bezel.
3. Extract the screw located in the top edge of the dash panel at the instrument cluster.
4. Carefully pry out on the dash bezel to release the fastening clips securing the bezel to the dash and unplug headlight / misc. switches on the driver's (left) of the bezel.

CAUTION: At this point, take care around the hazard switch, by tilting the wheel down and/or depressing the switch so the panel will clear. Also take care to snap the passenger air bag switch from the dash panel and push it back through its own hole rather than unplugging the switch. It is a costly repair bill in excess of \$400 to replace the hazard switch.

5. Remove the dash bezel from the vehicle.

USE THE SHADED BRACKETS & THE INDICATED HOLE LOCATIONS. CUT OFF THE REMAINING BRACKETS & DISCARD.
Usa los soportes asombrados y las localizaciones de aberturas indicadas. Corta los soportes que sobran y deséchalas.

1986-94 Chevrolet S-10 Blazer
1986-93 Chevrolet S-10 Pickup
1986-94 GMC S-15 Jimmy
1986-93 GMC S-15 Pickup
1991-94 Oldsmobile Bravada

RADIO REMOVAL:

1. Open the glove box door and remove the two screws from the radio trim panel.
2. Remove the ashtray and remove one screw from the upper inside corner of the recess and one from the lower inside corner. Remove the trim panel.
3. Remove the two screws which secure the radio to the dash, disconnect the wiring, and remove the radio.

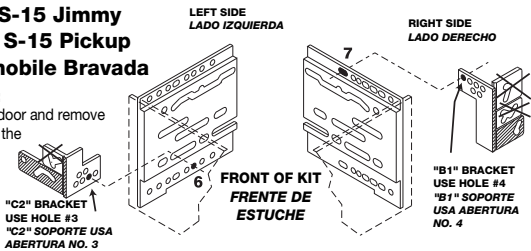

USE THE SHADED BRACKETS & THE INDICATED HOLE LOCATIONS. CUT OFF THE REMAINING BRACKETS & DISCARD.
 Usa los soportes asombrados y las localizaciones de aberturas indicadas. Corta los soportes que sobran y deséchalas.

1982-85 Chevrolet S-10 Blazer, Pickup
1982-85 GMC S-15 Jimmy, Pickup

RADIO REMOVAL:

1. Remove the four screws from the radio trim panel.
2. Remove the single screw from the lower right corner of the instrument cluster trim panel.
3. Remove the radio trim panel.
4. Remove the four screws retaining the radio/dummy panel. Pull the radio out of the cavity, disconnect the antenna, speaker leads, and all the electrical connections, then remove the radio.

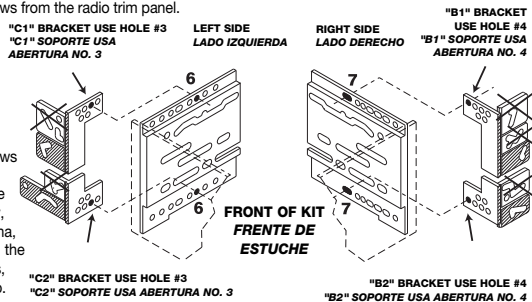

USE THE SHADED BRACKETS & THE INDICATED HOLE LOCATIONS. CUT OFF THE REMAINING BRACKETS & DISCARD.
 Usa los soportes asombrados y las localizaciones de aberturas indicadas. Corta los soportes que sobran y deséchalas.

1988-95 Chevrolet Van, Full Size
1988-95 GMC Van, Full Size

RADIO REMOVAL:

1. Remove the two screws from the top inside of the ashtray area.
2. Remove the two screws from the bottom front of the engine hump cover, pull the cover off and remove the electrical harnesses. Then remove the engine hump cover/shell.
3. Remove the single screw from the right side of the chassis securing the rear support bracket to the firewall. (A 10mm socket wrench will be needed).
4. Carefully snap off the radio trim piece.
5. Remove the two screws (10mm) securing the radio to the dash, one at each side of the chassis.
6. Pull the radio out of the cavity, remove the antenna lead, disconnect the wire harnesses and remove the radio.

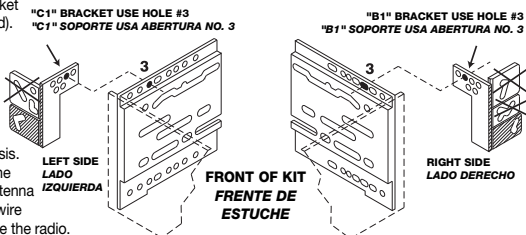

USE THE SHADED BRACKETS & THE INDICATED HOLE LOCATIONS. CUT OFF THE REMAINING BRACKETS & DISCARD.
 Usa los soportes asombrados y las localizaciones de aberturas indicadas. Corta los soportes que sobran y deséchalas.

1997-99 Chevrolet Venture
1997-99 Oldsmobile Silhouette
1997-99 Pontiac Trans Sport

RADIO REMOVAL:

1. Open ashtray and extract one from lower right side of dash bezel.
2. Open 12V socket cover and extract one from lower left dash bezel.
3. Lift bottom of dash bezel out to allow top edge to unhook from under air vents, unplug lighter, switches and remove dash.
4. Extract two 7mm hex head screws holding radio in, unplug connectors and remove radio.

"A1" BRACKET USE HOLE #2
 "A1" SOPORTE USA
 ABERTURA NO. 2

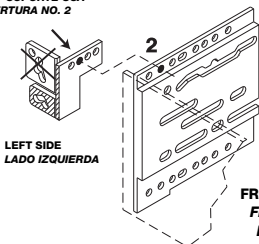

"B1" BRACKET USE HOLE #2
 "B1" SOPORTE USA ABERTURA NO. 2

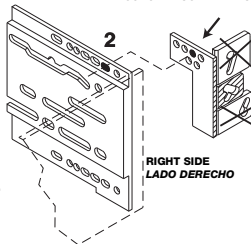

USE THE SHADED BRACKETS & THE INDICATED HOLE LOCATIONS. CUT OFF THE REMAINING BRACKETS & DISCARD.
 Usa los soportes asombrados y las localizaciones de aberturas indicadas. Corta los soportes que sobran y deséchalas.

1992-95 Oldsmobile Achieva

RADIO REMOVAL:

1. Extract the two screws from the bottom of the dash bezel, below the radio and above the console pocket, securing it to the dash.
2. Extract the two screws above the instrument cluster.
3. Remove the two screws above the AC vent located in the center of the dash.
4. Pull the dash bezel out away from the dash and using a panel removal tool/screwdriver, carefully disconnect the fastening clips securing the dash vents (the one in the center and the one on the driver's side) to the bezel.
5. Disconnect all the connectors and slide the dash bezel away from the dash towards the passenger side.
6. Extract the two 10mm bolts securing the radio to the dash, pull the radio from the cavity, unplug all the connectors, and remove the radio.

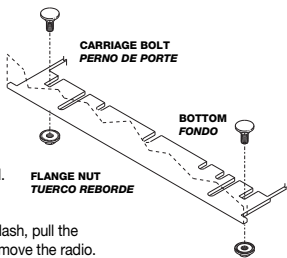

SECURE THE KIT PANEL TO THE DASH USING THE SUPPLIED CARRIAGE BOLTS AND NUTS.
 Asegure el panel estuche al tablero usando los pernos de porte y tuercos proveídos.

1985-91 Oldsmobile Cutlass Calais

RADIO REMOVAL:

1. Open armrest and extract (2) Phillips head screws from bottom of pocket.
2. Remove pocket and extract (2) 10mm bolts from underneath. Lift and slide armrest towards rear of car.
3. Extract (2) 7mm/t-15 bolts from rear edge of gear select lever trim panel. Remove ashtray (on center console) and extract (1) 7mm/t-15 bolt from underneath.
4. Put car in low gear. Lift and slide center console towards rear of car.
5. Gently unsnap and remove radio trim bezel.
6. Extract (2) 7mm/T-15 Torx screws securing radio to the dash, unplug wiring, antenna, and remove radio.

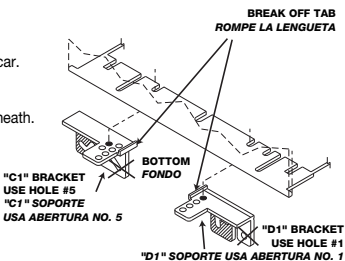

USE THE SHADED BRACKETS & THE INDICATED HOLE LOCATIONS. CUT OFF THE REMAINING BRACKETS & DISCARD.
 Usa los soportes asombrados y las localizaciones de aberturas indicadas. Corta los soportes que sobran y deséchalas.

1982-96 Oldsmobile Cutlass Ciera

RADIO REMOVAL:

1. Remove the ashtray from the mounting bracket.
2. Extract the two screws from the padded portion of the dash in the ashtray location.
3. Remove the single screw from the trim ring below the steering column and remove the trim.
4. Remove the two screws from the top of the trim above the steering column and remove the trim.
5. Carefully pry out each A/C vent, one on each side of the steering column.
6. Remove the two screws from the left A/C vent location and one screw from the right A/C vent location.
7. Carefully pry out the padded portion of the dash trim.

8. Remove the four screws from inside the top edge of the instrument cluster trim and the four screws from the bottom edge and remove the trim.
9. Remove the four screws from the radio bracket/dummy panel; pull the radio out of the cavity, disconnect the antenna, speaker leads and all the electrical connections. Then remove the radio.

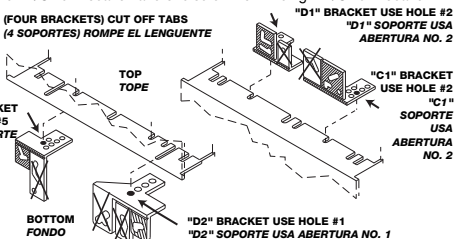

USE THE SHADED BRACKETS & THE INDICATED HOLE LOCATIONS. CUT OFF THE REMAINING BRACKETS & DISCARD.
Usa los soportes asombrados y las localizaciones de aberturas indicadas. Corta los soportes que sobran y deséchalos.

1984-88 Oldsmobile Cutlass Supreme Classic

RADIO REMOVAL:

1. Carefully pry outward on each corner of the radio trim panel to release the spring clips.
2. Unscrew the cigarette lighter housing and remove the panel.
3. Remove the four screws from the radio mounting bracket and pull the unit out of the cavity. Disconnect the antenna, speaker leads and all the electrical connections, then remove the radio.

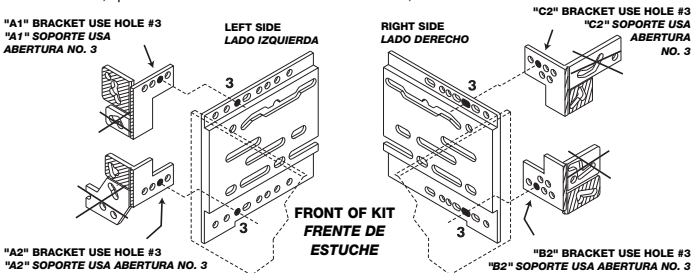

USE THE SHADED BRACKETS & THE INDICATED HOLE LOCATIONS. CUT OFF THE REMAINING BRACKETS & DISCARD.
Usa los soportes asombrados y las localizaciones de aberturas indicadas. Corta los soportes que sobran y deséchalos.

1989-94 Oldsmobile Cutlass Supreme

RADIO REMOVAL:

1. Remove the five screws from the top underside of the radio/instrument trim panel. Carefully release the clips from along the bottom edge of the panel to remove it.
2. Remove the two screws securing the radio to the dash, and pull the radio out of the cavity. Disconnect the wire harnesses and the antenna lead then remove the radio.

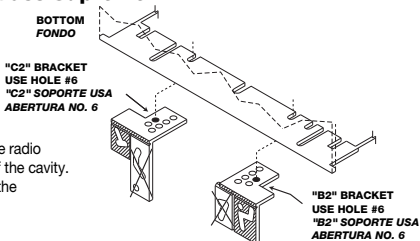

USE THE SHADED BRACKETS & THE INDICATED HOLE LOCATIONS. CUT OFF THE REMAINING BRACKETS & DISCARD.
Usa los soportes asombrados y las localizaciones de aberturas indicadas. Corta los soportes que sobran y deséchalos.

1986-88 Oldsmobile Delta 88

1989-91 Oldsmobile Eighty-Eight Royale

1984-93 Oldsmobile Ninety-Eight

RADIO REMOVAL:

- Place the gear shift lever in the D1 position. Pull the rubber steering column trim boot towards the rear of the car.
- Remove the four screws from the heater control/vent trim panel. Very carefully pull the entire trim panel away from the dash and remove the trim panel.
- Extract the single screw from each end of the padded radio trim panel.
- Remove the four screws from the bottom of the radio/dash trim panel.
- Extract the seven screws from the top of the radio/dash trim panel.
- Unhook the ashtray/light wiring terminal located directly behind the ashtray.
- Remove the trim panel.
- Remove the four screws which secure the radio to the dash and slide the radio out of the cavity. Disconnect the antenna, speaker leads and all the electrical connections, then remove the radio.

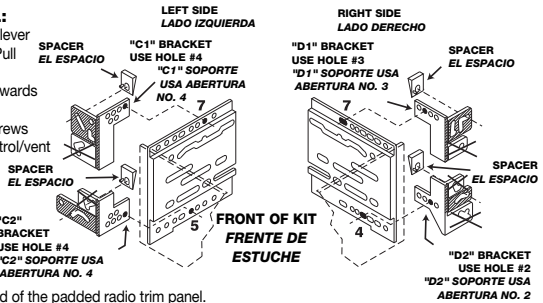

USE THE SHADED BRACKETS & THE INDICATED HOLE LOCATIONS. CUT OFF THE REMAINING BRACKETS & DISCARD.
Usa los soportes asombrados y las localizaciones de aberturas indicadas. Corta los soportes que sobran y deséchalos.

1992-93 Oldsmobile Eighty-Eight Royale

RADIO REMOVAL:

- Extract the three screws securing the radio trim/dash bezel from above the instrument cluster and the radio.
- Remove the screws on each side of the steering column that secure the radio trim/dash bezel. Carefully pull out on the bezel to remove it.
- Extract the four screws securing the radio to the dash, pull the radio from the cavity, unplug all the connectors and remove the radio.

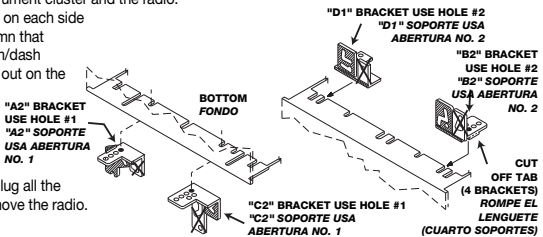

USE THE SHADED BRACKETS & THE INDICATED HOLE LOCATIONS. CUT OFF THE REMAINING BRACKETS & DISCARD.
Usa los soportes asombrados y las localizaciones de aberturas indicadas. Corta los soportes que sobran y deséchalos.

1983-84 Oldsmobile Omega

RADIO REMOVAL:

- Remove the four screws retaining the panel below the steering column and remove the panel.
- Extract the four screws from inside the top edge of the instrument cluster trim.
- Remove the two screws from the lower instrument cluster trim, one on each side of the steering column.
- Remove the dash trim panel.
- Remove the four 7mm hex screws from the radio brackets/dummy panel. Pull the radio out of the cavity, disconnect the antenna, speaker leads and all the electrical connections, then remove the radio.

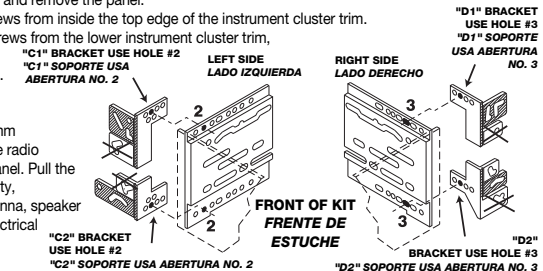

USE THE SHADED BRACKETS & THE INDICATED HOLE LOCATIONS. CUT OFF THE REMAINING BRACKETS & DISCARD.
Usa los soportes asombrados y las localizaciones de aberturas indicadas. Corta los soportes que sobran y deséchalos.

1982-89 Oldsmobile Toronado

RADIO REMOVAL:

1. Remove the five screws from the top underside of the dash trim.
2. Lower the tilt wheel and gently pull out on the trim piece from the top side. This allows clearance to disconnect the electrical connections.

Remove the connections and the panel.

3. Remove the ten screws securing the climate controls and the radio, six screws from the climate controls and four screws from the radio.
4. Disconnect the antenna, speakers, and all the electrical connections and remove the radio.

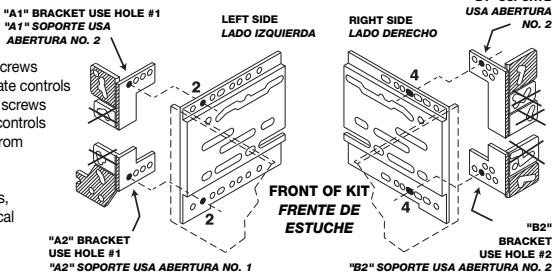

USE THE SHADED BRACKETS & THE INDICATED HOLE LOCATIONS. CUT OFF THE REMAINING BRACKETS & DISCARD.

Usa los soportes asombrados y las localizaciones de aberturas indicadas. Corta los soportes que sobran y deséchalas.

1989-93 Oldsmobile Touring Sedan

RADIO REMOVAL:

1. Open the center console storage compartment, then remove the two screws securing the storage sleeve/pocket. Remove the sleeve/pocket insert.
2. Remove the two screws from the front edge of the console pocket (at the wood trim), then remove the trim section.
3. Pop out and remove the electric seat control panel (located in the center console).
4. Carefully snap off the trim piece from around the gear selector, then remove the four screws securing the wood trim to the console substructure.

5. Remove the wood trim piece from the top of the console, pull the trim piece back and up to remove. Disconnect the wire harnesses and remove the trim piece.

6. Extract the four screws which secure the radio, pull the radio out of the cavity, disconnect the wire harnesses and the antenna, then remove the radio.

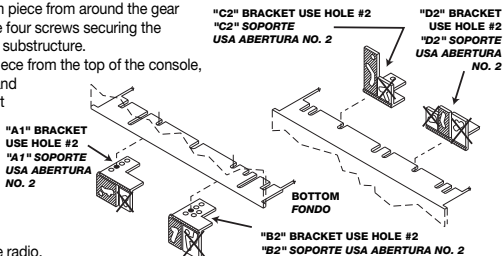

USE THE SHADED BRACKETS & THE INDICATED HOLE LOCATIONS. CUT OFF THE REMAINING BRACKETS & DISCARD.

Usa los soportes asombrados y las localizaciones de aberturas indicadas. Corta los soportes que sobran y deséchalas.

1992-99 Pontiac Bonneville

RADIO REMOVAL:

1. Using a panel removal tool/screwdriver, carefully release the fastening clips from around the perimeter of the radio trim bezel and remove the panel.

2. Extract the three screws securing the radio to the dash, pull the radio from the cavity, unplug all the connectors and remove the radio.

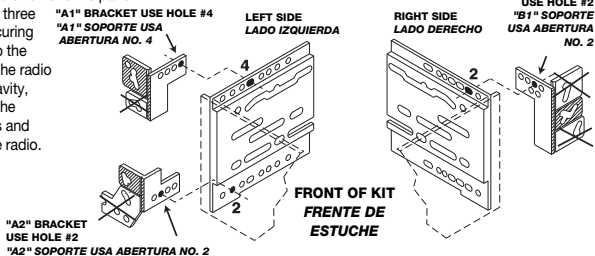

USE THE SHADED BRACKETS & THE INDICATED HOLE LOCATIONS. CUT OFF THE REMAINING BRACKETS & DISCARD.

Usa los soportes asombrados y las localizaciones de aberturas indicadas. Corta los soportes que sobran y deséchalas.

1987-91 Pontiac Bonneville

RADIO REMOVAL:

1. Place the gear selector in low gear to gain clearance.
2. Gently pull on the edges of the radio panel to release the panel clips and remove the panel.
3. Remove the two screws from the bracket above the radio.
4. Remove one screw from the rear support bracket (access through the ashtray cavity).
5. Insert a thin blade screwdriver into the two slots below the radio and pry the metal retaining tabs upward to release them.
6. Slide the radio out of the cavity, disconnect all the electrical connections, then remove the radio.

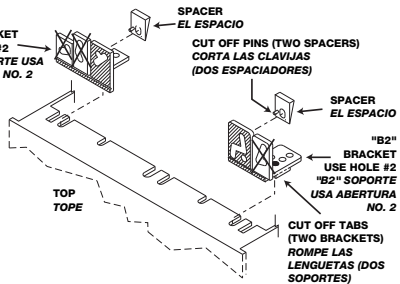

USE THE SHADED BRACKETS & THE INDICATED HOLE LOCATIONS. CUT OFF THE REMAINING BRACKETS & DISCARD.
 Usa los soportes asombrados y las localizaciones de aberturas indicadas. Corta los soportes que sobran y deséchalos.

1984-88 Pontiac Fiero

RADIO REMOVAL:

1. Remove the four screws from the radio trim panel.
2. Pull the panel up and outward toward the right.
3. Remove the four screws from the radio brackets and pull the radio out of the cavity.
4. Disconnect the antenna, speaker leads and all the electrical connections, then remove the radio.

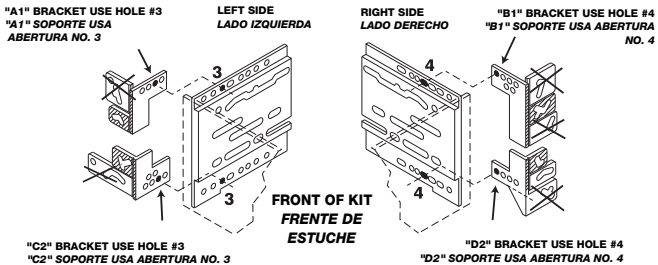

USE THE SHADED BRACKETS & THE INDICATED HOLE LOCATIONS. CUT OFF THE REMAINING BRACKETS & DISCARD.
 Usa los soportes asombrados y las localizaciones de aberturas indicadas. Corta los soportes que sobran y deséchalos.

1993-02 Pontiac Firebird

RADIO REMOVAL:

1. Using a panel removal tool/screwdriver, carefully release the fastening clips from around the perimeter of the radio trim bezel and remove the bezel.
2. Extract the four screws securing the radio to the dash, pull the radio from the cavity, unplug all the connectors, and remove the radio.

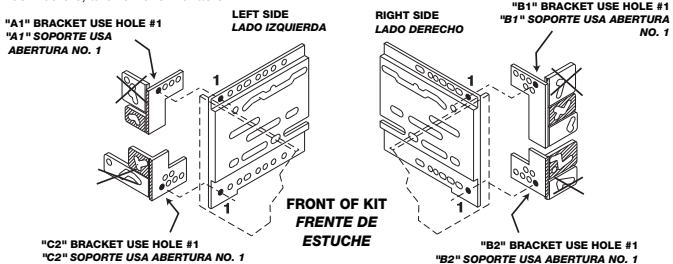

USE THE SHADED BRACKETS & THE INDICATED HOLE LOCATIONS. CUT OFF THE REMAINING BRACKETS & DISCARD.
 Usa los soportes asombrados y las localizaciones de aberturas indicadas. Corta los soportes que sobran y deséchalos.

1985-92 Pontiac Firebird

RADIO REMOVAL:

- Carefully pull on the edges of the radio trim panel to release the panel clips and remove the panel.
- Remove the four screws which secure the radio to the console.
- Disconnect the antenna, speaker leads and all the electrical connections, then remove the radio.

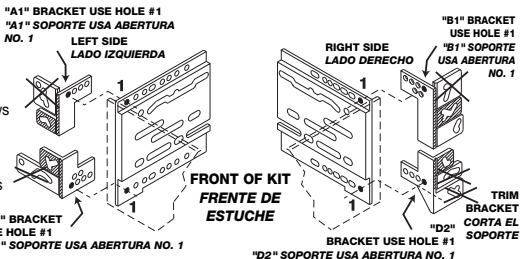

USE THE SHADED BRACKETS & THE INDICATED HOLE LOCATIONS. CUT OFF THE REMAINING BRACKETS & DISCARD.
 Usa los soportes asombrados y las localizaciones de aberturas indicadas. Corta los soportes que sobran y deséchalas.

1996-98 Pontiac Grand Am

RADIO REMOVAL:

- Extract two screws from the dash bezel above instrument/gauges.
- Extract two screws from back of deep storage pocket below the radio.
- Carefully pull out on the instrument/radio panel to release snap clips, unplug switches and remove bezel.
- Extract three 7mm screws securing radio, unplug connectors, antenna lead, and remove radio.

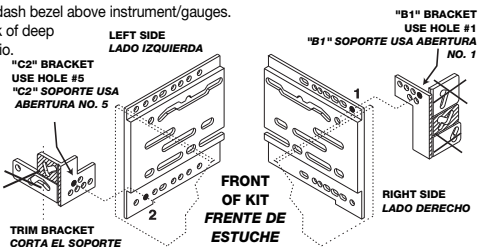

USE THE SHADED BRACKETS & THE INDICATED HOLE LOCATIONS. CUT OFF THE REMAINING BRACKETS & DISCARD.
 Usa los soportes asombrados y las localizaciones de aberturas indicadas. Corta los soportes que sobran y deséchalas.

1992-1995 Pontiac Grand Am

RADIO REMOVAL:

- Extract the screw from the underside of the radio trim bezel.
- Extract the five screws from the upper glove box securing the glove box assembly and remove the glove box.
- Open up the lower glove box and extract the three screws securing the radio trim bezel near the pin switch.
- Extract the three screws from below the steering column that secure the top of the driver's side lower dash.
- Extract the five screws securing the lower section of the driver's side lower dash panel and remove the panel.
- Extract the screw securing the radio trim bezel behind the driver's side lower dash panel.
- Using a panel removal tool/screwdriver, carefully pry the radio trim bezel outward to release and remove it.
- Remove the two nuts from below the radio cavity securing the radio to the dash, pull the radio from the cavity, unplug the leads and remove the radio.

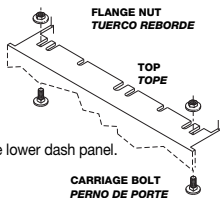

SECURE THE KIT PANEL TO THE SUB-DASH USING THE SUPPLIED CARRIAGE NUTS AND BOLTS.
 Asegura el panel estuche al tablero-sub usando los tuercos y pernos de porte.

1985-91 Pontiac Grand Am

RADIO REMOVAL:

- Unsnap the front edge of the gearshift trim piece from the center console.
- Gently pull on the radio trim panel to release the snaps and remove the trim.
- Remove the two screws which secure the radio and slide the radio out of the cavity.
- Disconnect the antenna, speaker leads and all the electrical connections, then remove the radio.

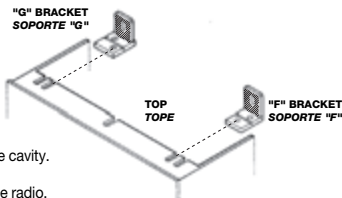

SECURE THE KIT PANEL TO THE SUB-DASH USING THE SUPPLIED CARRIAGE NUTS AND BOLTS.
 Asegura el panel estuche al tablero-sub usando los tuercos y pernos de porte.