

VEHICLE DISASSEMBLY

2006 TOYOTA RAV4

Radio Removal

1. Using a panel removal tool, remove both left and right panels located on each side off the radio.
2. Remove the (4) 10mm bolts securing the radio to the dash. Disconnect and remove.

MOUNTING THE RADIO

DIN-ISO MOUNT

1. Snap the 6117L and 6117R brackets to the mounting locations on the 6113 kit panel. Secure the 6116 pocket to the 6117L/R brackets with the supplied hardware in the installation kit.
2. Align the pocket to the lower edge of the opening in the panel. Then slide in, as shown. (See Illustration 2).
3. Install (2) pocket screws as shown. (See Illustration 2).
4. Align, position and bolt the aftermarket DIN-ISO head unit to the 6117L/6117R brackets. Use hardware supplied with aftermarket radio to secure the mounting brackets to the aftermarket radio.
5. Snap the 6114 single DIN trim ring to complete mounting.

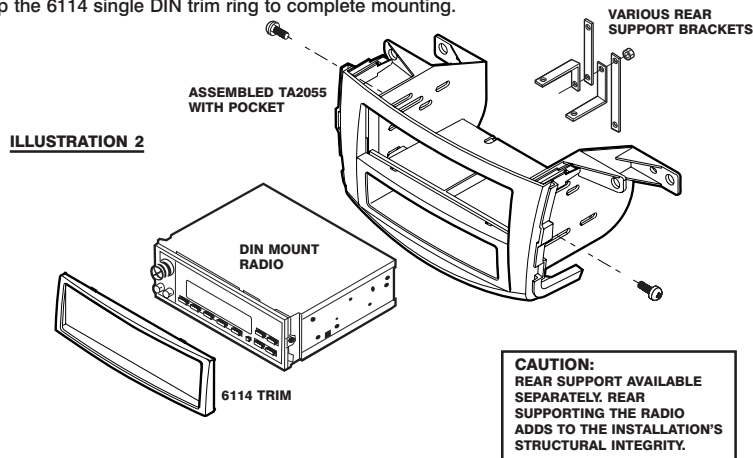

DOUBLE-DIN ISO MOUNT

1. Snap the 6117L and 6117R brackets to the mounting locations on the 6113 kit panel.
2. Align, position and bolt the aftermarket DIN-ISO head unit to the 6117L/6117R brackets. Use hardware supplied with aftermarket radio to secure the mounting brackets to the aftermarket radio.
4. Snap the 6115 double DIN trim ring to complete mounting.

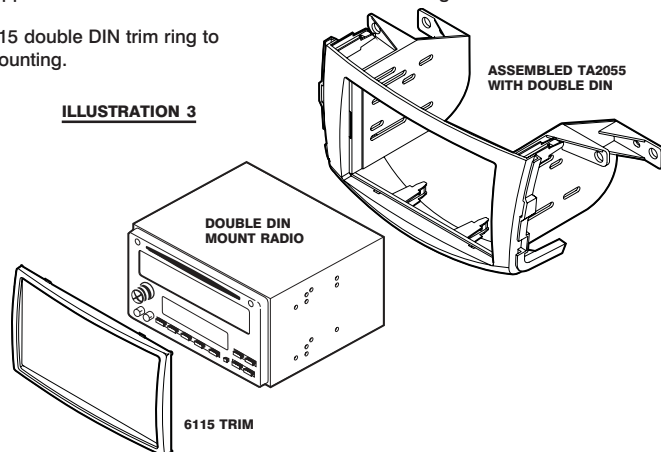

SCOSCHE

TA2055B

IN-DASH INSTALLATION KIT FOR 2006-UP TOYOTA RAV4

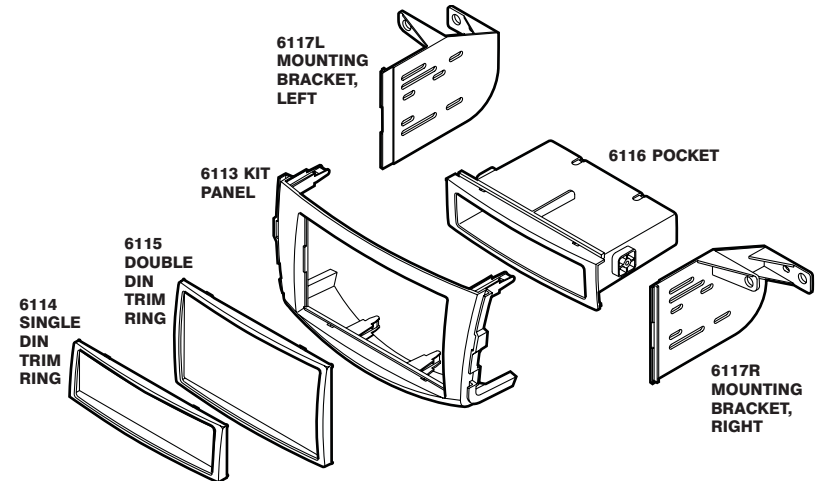

INTRODUCTION / PRELIMINARY

This premium installation kit is for 2006-Up Toyota RAV4 vehicles. Included are all the parts you need to mount your car stereo/cassette or CD player into your vehicle's dash. Refer to the individual instruction in this manual to remove your vehicle's factory radio and assemble the kit.

CAUTION:

DISCONNECT YOUR VEHICLE'S NEGATIVE BATTERY TERMINAL BEFORE THE INSTALLATION TO HELP PREVENT ELECTRICAL DAMAGE. WE RECOMMEND THE USE OF A VOLT/OHM METER OVER A TEST LIGHT TO CHECK WIRING. A TEST LIGHT OR GROUNDED WIRE PROBE CAN CAUSE DAMAGE TO THE VEHICLE'S COMPUTER AND/OR DIAGNOSTIC SYSTEMS. AVOID ALL FACTORY AIRBAG WIRING - AIRBAGS CAN ACCIDENTALLY DEPLOY CAUSING SERIOUS INJURY OR DEATH.

NOTES:

- See your vehicle's instructions for any special tools your installation might require.
- Read all instructions accompanying your car stereo/cassette player for proper wiring and mounting instructions.

CAR STEREO CONNECTORS

PROVIDE EASY CONNECTION OF YOUR CAR STEREO TO FACTORY WIRING HARNESS.

TA02
1987-UP Toyota



LIABILITY DISCLAIMER

This instruction booklet is based on carefully documented data and research of automobile dash disassembly, wire harness/ codes and information pertaining to installation of this kit (TA2055B) in 2006 Toyota RAV4 Vehicles. Scosche Industries, Inc. can not be held responsible for discrepancies/inconsistencies that may occur due to the automobile manufacturing changes or options, or damage that may occur in the automobile during the installation of components while using this booklet.