

OTHER CLASS II GENERAL MOTORS OEM INTEGRATION PRODUCTS:

DCGMOS210B:

OnStar® Interface for Class 2 non-Bose® vehicles. Retains OnStar functions when replacing Factory GM radio.

DCGMOS2B11B:

OnStar® Interface for Class 2 Bose® and Premium Bose® vehicles. Retains OnStar functions when replacing Factory GM stereo with Digital Bose Audio systems

DCGMCM2B12B:

Add on Chime Module for use with DCGMOS210B, DCGMOS2B11B

AXIPGMCL2:

iPod/Aux Input OEM integration interface. All Full control of iPod functions from Factory radio, plus adds an additional RCA Aux input. Provides iPod 30-pin dock connector with charging when iPod is plugged in. Provides a +12V ACCESSORY switched output for external accessories such as a mobile DVD player. Plug and play installation. Compatible with OnStar systems, Factory Navigation systems, Factory XM radio and Standard CD radios. Not compatible with external 6-Disc GM Changers.

AXGM:

Aux Input interface. Provides 1 set of RCA Aux inputs to Factory stereo. Not compatible with Factory XM radio or external CD/Cassette/CD changer units. Plug and play installation.

GMAUX216:

Aftermarket Amplifier interface. Allow connection of 2-channel Aftermarket amp to Factory radio. Audio output is selectable Fade or Non-Fading. Provides +12V remote turn-on output for Aftermarket Amplifier.



GM09SR

FACTORY STEREO REPLACEMENT INTERFACE WITH CHIME (CLASS II DATA SYSTEM)

VEHICLE APPLICATIONS:

BUICK		GMC	
2004-05 Century		2004-07 Canyon	
2004-06 Rainier		2003-07 Savana	
2005-UP Terraza		2003-04 Sonoma	
CHEVROLET		2003-06 Sierra Pickup	
2003-06 Avalanche		1500/3500	
2003 Blazer S-10		2007 Sierra Pickup	
2000-05 Cavalier		Classic	
2004-07 Colorado		ISUZU	
2003-07 Express		2003-06 Ascender	
2000-05 Impala		OLDSMOBILE	
2001-03 Malibu		2001-03 Alero	
2000-05 Monte Carlo		2002-04 Bravada	
2003-06 Silverado Pickup		2000-01 Silhouette	
1500/3500		(w/Integrated chime)	
2007 Silverado Pickup		2002-05 Silhouette	
Classic		PONTIAC	
2003-06 Suburban		2001-05 Aztek	
2003-06 Tahoe		2001-05 Grand Am	
2000-01 Venture		2000-01 Montana	
(w/Integrated chime		(w/Integrated chime)	
from door)		2002-05 Montana	
2002-05 Venture		2000-05 Sunfire	

APPLICATION NOTES:	STD. RADIO	STD. BOSE	PREMIUM BOSE	ONSTAR
Not for use on "Premium Bose" or OnStar systems. See list and note below.	Yes	Yes	No	No

POSSIBLE "PREMIUM BOSE" APPLICATIONS:

2002-05 BUICK Rendezvous	2003-06 GMC Envoy SLT
2003-06 CADILLAC Escalade/ESV/EXT	2002-06 GMC Sierra Denali
2002-06 CHEVROLET TrailBlazer LS/LTZ	2003-06 GMC Yukon/Yukon XL/Denali
2003-06 HUMMER H2	

How to Test for "Premium Bose" systems:

There are 2 types of Bose systems available in some models of vehicles listed above. Turn factory radio volume up and down rapidly. If the sound system reacts immediately then the system is a standard BOSE, not a Premium BOSE. If the sound system volume does not react immediately, but has a noticeable delay, the system is a Premium BOSE and not compatible with the GM09SR. If "Premium" Bose Amplifier is not used or is bypassed, then the GM09SR can be used to retain warning chimes only. Alternate parts are available to INTEGRATE "Premium Bose" and OnStar systems.

PRELIMINARY

This GM09SR Car Stereo Replacement interface will allow you to replace your GM Factory stereo and retain all safety and warning chimes with your NEW Aftermarket Car Stereo.

BEFORE BEGINNING: READ THIS INSTRUCTION MANUAL

****CAUTION**:**

Disconnect Negative Battery Terminal to avoid short circuits. Read ALL manufacturers warnings regarding air bags and Electrical systems in your vehicle. We recommend the use of a volt-ohm meter or computer-safe LED probe when checking wiring. A test light or grounded light probe if used improperly can cause damage to the vehicle's computer and/or diagnostic system.

NOTE: We recommend the GM1583B for DIN installations or a GM1590AB Kit for DOUBLE DIN installations.

WHY YOU NEED THIS PART:

Your Factory stereo is an integral part of your vehicle's SAFETY and WARNING CHIME systems. If the stereo is removed without the proper installation accessory, various warning chimes and/or some functions of your vehicle may be LOST including:

- Seatbelt warning chime
- Key left in ignition chime
- Lights left on chime
- +12V Accessory Power at Radio's location
- RAP (Retained Accessory Power)
- Low fuel
- Check Engine/Service indicator
- Low oil level

Your vehicle's ECM (Electronics Control Module) will also store an error code if operated without the factory radio installed and you may experience difficulty in having the vehicle serviced at the dealership. The GM09SR Interface module / harness allows you to REPLACE the factory stereo and RETAIN all SAFETY and WARNING chimes. Additionally, GM09SR will send the proper data commands to your vehicle's ECM (Electronics Control Module) to indicate a "Healthy" status for diagnostic purposes. The GM09SR Module/Harness ALSO provides a RED +12V Switched ACCESSORY Power source for your aftermarket stereo.

WARRANTY / DISCLAIMER

Scosche Industries, Inc. warrants this product to be free from defects in material and workmanship, for a period of 90 days from the date of purchase. This Scosche product is sold with the understanding that purchaser has independently determined the suitability of this product. This warranty DOES NOT cover any expenses incurred from the installation, removal, or re-installation of this product, incidental or otherwise. This warranty is offered to the original purchaser of the product only. This warranty does not cover the product if physically damaged, subjected to negligence or misuse, abuse, improper installation, alteration, accident, or an act of God. Also excluded from the warranty are costs from the correction of faulty installation, and elimination of electromagnetic interference (engine noise). The original dated sales slip or proof of purchase will establish warranty eligibility. If the product should prove defective within the warranty period, Scosche at its option will repair or replace the product free of charge. In no event shall Scosche be responsible for claims beyond the replacement value of the defective product or in any way be liable or responsible for consequential or incidental damages. Scosche Industries, Inc. cannot be held responsible for discrepancies/inconsistencies that may occur due to manufacturing changes or options.

GM09SR CHIME VOLUME ADJUSTMENT

CHIME AUDIO LEVEL ADJUSTMENT

The GM09SR interface gives you the ability to adjust the chime audio level from soft to loud in order to suit your personal needs. Follow the steps below:

1. With the Ignition key OFF and Key resting in ignition, turn ON Vehicle headlights.
2. Open driver's door. At this point you will hear a reminder chime indicating the Key is in the ignition and lights are on.
3. SLOWLY, rotate the dash illumination dimmer knob to make chime audio adjustments. Turn the knob up to increase chime volume level or turn it down to decrease.
4. Once the desired volume level is achieved, turn off headlights and close the door.

Your personal chime setting will be stored by the GM09SR. You can re-adjust your dash lighting dimmer level with the door CLOSED and headlights on.

OPERATION

There are no specific "user operational steps for this product other than CHIME ADJUSTMENT as stated ABOVE. When connected and installed per these instructions, your Aftermarket Car Stereo should operate just like the Factory System did. All Chimes will be re-produced by the speaker built inside the GM09SR located in the dash behind your stereo. The Retained Accessory Power function of the stereo will continue to operate as normal. The GM09SR module will send the proper DATA commands to your vehicle's Electronics Module to keep your vehicle's Diagnostics System functioning normally as with the Factory Stereo.

Consult your Stereo Owner's Guide for info specific to the operations of your new Car Stereo.

FACTORY CHIMES PRODUCED BY THE GM09SR:

- Seatbelt warning chime
- Key left in ignition chime
- Lights left on chime
- Low fuel
- Service reminders/warnings when displayed on instrument cluster

GM09SR OVERVIEW

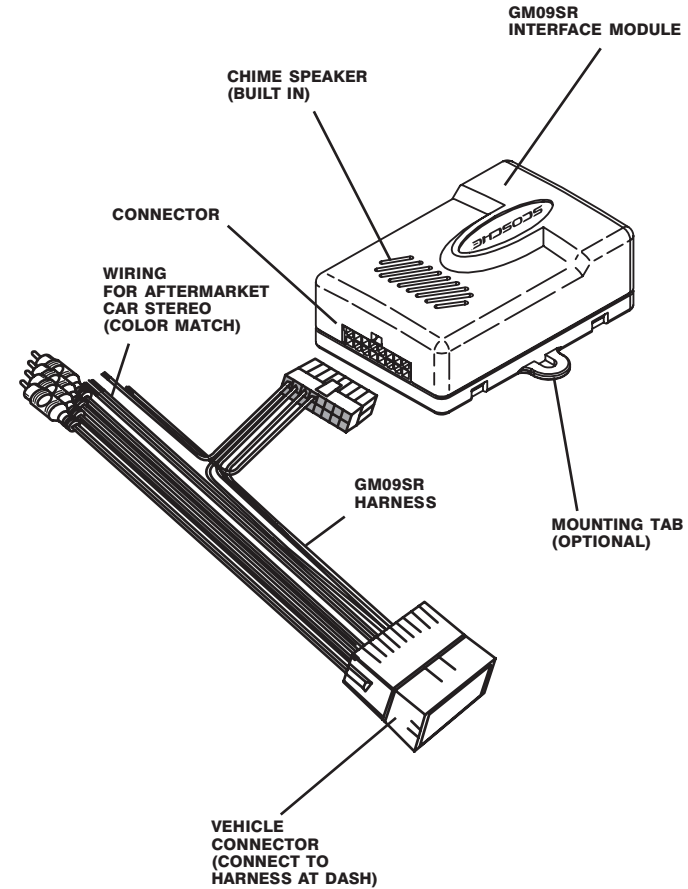

WIRING INSTRUCTIONS

1. Disconnect the Negative battery cable from the battery to avoid any short circuits.
2. Remove and unplug factory stereo. (If needed, call Scosche Tech Support (800) 621-3695 x3 for stereo removal steps specific to your vehicle.)
3. Match and connect the appropriate wires from the GM09SR harness to the appropriate wires of the plug provided with your stereo. For example, connect the +12V Yellow Constant lead from your stereo to the Yellow wire of the GM09SR Harness. The color codes are designed to match MOST brand of car stereos.
 - A. For NON-Bose installations, cut off RCA cable ends and connect directly to color coded speaker wires. For STD BOSE systems, USE RCA line outputs from stereo.
4. Note that the RED +12V switched wire for your aftermarket is coming from the GM09SR module itself, not the vehicle harness.
5. Tape all unused wires to prevent short circuiting.
6. Reconnect the Negative battery cable
7. Connect the 16-Pin harness to the GM09SR module.
8. Connect the 24-Pin GM09SR connector to the Factory Harness.
9. As you install your new stereo, place the GM09SR module in the rear of the dash cavity behind the stereo. (Optional: Cable ties or double sided tape can be used to secure the module, but are not included.)

WIRING NOTES:

1. The Red +12V Accessory wire coming from the GM09SR module is rated at 5 Amps Max for a SINGLE Aftermarket Car Stereo only. Connecting additional accessories to the RED wire can cause DAMAGE to the GM09SR module!
2. There additional Yellow, Black and Violet wires PRE-CONNECTED between the GM09SR connector and the Vehicle 24 PIN connector. These are Power and Data wires for the module itself. DO NOT MAKE ANY CONNECTIONS with these wires.
3. If your stereo does not contain an "illumination" wire, then the Orange wire will not be used. Tape or terminate all unused wires to prevent short circuits.

NON-BOSE WIRING DIAGRAM

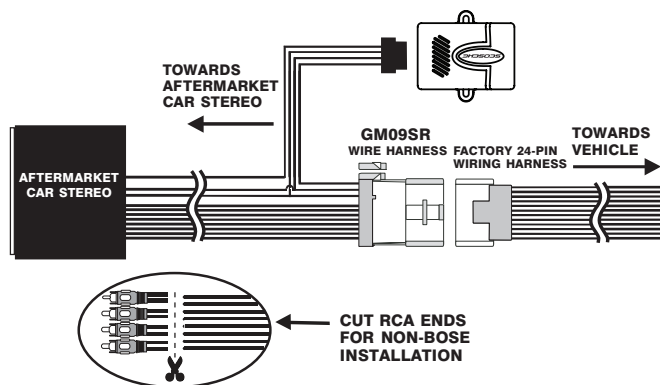

STANDARD BOSE WIRING DIAGRAM

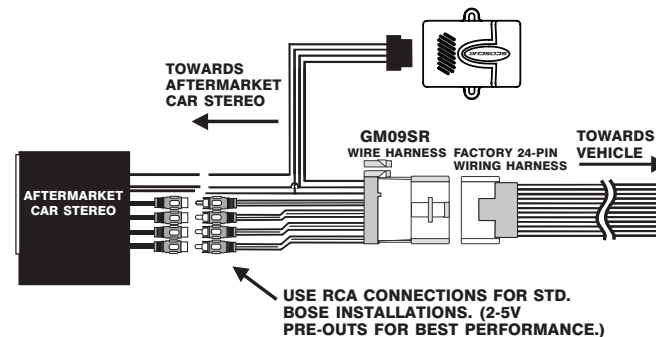

WIRING CODES

White	= Left Front Positive (LF+)	Green	= Left Rear Positive (LR+)
White/Black	= Left Front Negative (LF-)	Green/Black	= Left Rear Negative (LR-)
Violet/Black	= Right Rear Negative (RR-)	Gray/Black	= Right Front Negative (RF-)
Violet	= Right Rear Positive (RR+)	Gray	= Right Front Positive (RF+)
Black	= Chassis Ground (-12V)	Orange	= Illumination
Yellow	= +12 Volt Battery Constant		
Red	= +12 Volt Ignition Switched (5Amp output from GM09SR module)		

NOTE: This output is rated at 5 amps. It designed for Aftermarket headunits ONLY. If you are using other hi-demand accessories, we recommend the use of an SPDT relay to drive those devices and prevent damage to GM09SR circuitry.

Blue/White = +12V Remote Output (Amp remote, Radio ON Signal)
 Orange = +12 Volt Illumination (2Amp output from GM09SR module)

NOTE: This output is rated at 2 amps. It is designed for Aftermarket headunits with an illumination input ONLY. If you are using other hi-demand LIGHTED accessories such as aftermarket GAUGES, we recommend the use of an SPDT relay to drive those devices and prevent damage to GM09SR circuitry.

The color codes used on this Car Stereo Connector conform to the standards set by the E.I.A. (Electronics Industry Association). They may differ from the wiring codes found on your Car Stereo. Always refer to your stereo owners manual for wiring details about your particular Car Stereo.