

# SCOSCHE®

## FCJ1276A

### IN-DASH INSTALLATION KIT FOR 1974-UP FORD/CHRYSLER/LINCOLN MERCURY AND JEEP VEHICLES - INSTALLATION INSTRUCTIONS

## QUICK START GUIDE

### INTRODUCTION

The Scosche in-Dash Installation Kit for 1974-UP Ford/Chrysler/Lincoln/Mercury and Jeep Vehicles provides the parts you need to mount your car stereo/cassette player into your vehicle's dash. Refer to the individual instructions in this manual to remove your vehicle's factory installed radio.

### PRELIMINARY PARTS LIST

#### Your kit includes:

- 3 Mounting Panels
- 2 "A" Brackets (Left & Right)
- 2 "B" Brackets (Left & Right)
- 2 "C" Brackets (Left & Right)
- 2 Spacers
- 1 Rear Support Bracket
- 1 Hardware Pack
- 2 Tracer Bracket Spacers

### ASSEMBLING THE KIT

The instructions for each vehicle show which mounting panel and brackets to use.

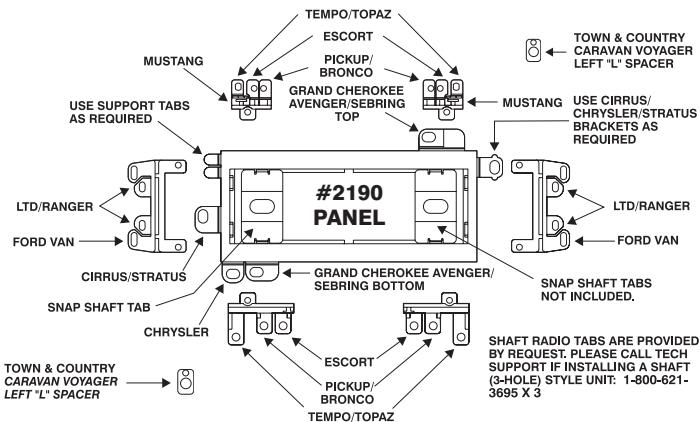

1999-04	300M	2000-05	NEON
1998-04	CONCORD	2000-05	PT CRUISER
2001-06	CARAVAN	2001-05	SEBRING CONVERTIBLE
2001-04	DAKOTA EXTRA CAB	2001-05	SEBRING COUPE
2001-03	DURANGO	2000-06	SEBRING 4-DR. SEDAN
1999-04	GRAND CHEROKEE	2001	STRATUS
2001-04	INTREPID	2002-06	STRATUS COUPE
1999-01	LHS	2001-06	TOWN & COUNTRY
2002-06	LIBERTY		

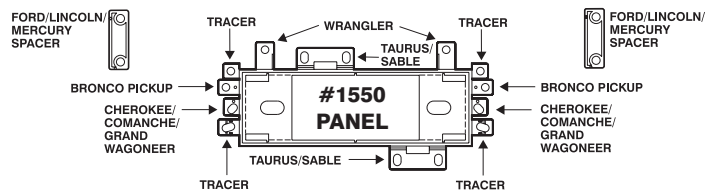

## QUICK START GUIDE

### PRELIMINARY

# STOP

BEFORE BEGINNING - Read QUICK START GUIDE PAGES 2-6

**CAUTION: BEFORE PROCEEDING WITH THE INSTALLATION, DISCONNECT YOUR VEHICLE'S NEGATIVE BATTERY CABLE TO PREVENT POSSIBLE ELECTRICAL SYSTEM DAMAGE.**

## STEP 1 PICK YOUR VEHICLE

Locate your vehicle on the front cover of this instruction.

## STEP 2 FACTORY RADIO?

Does your vehicle have the factory radio? If YES, proceed to next

**STEP 3**

If NO, go to **STEP 4**

## STEP 3 REMOVE FACTORY STEREO

Use the step's provided in the manual to remove factory radio.

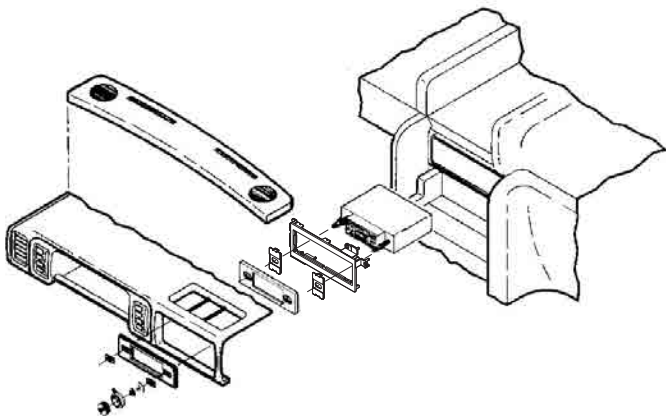

## QUICK START GUIDE

## STEP 4 KIT/PANEL ASSEMBLY

### FORD/LINCOLN/MERCURY:

#### TOP/BOTTOM:

Use the supplied carriage bolts and nuts to attach the factory mounting brackets directly to the kit panel as shown.

**NOTE:** If your bracket has small notches on it, they will have to be flattened out or filed off in order to mount the bracket to the top/bottom of the kit (see inset).

#### SIDES:

Attach the Factory Bracket Adapters FBA to left and right sides of the kit as shown. The FBA's locator pins should line up with the holes marked #1 on the sides of the kit panel. Be sure to insert a carriage bolt through the FBA facing outward through the square hole (see illustration). Repeat for both sides.

#### ATTACHING THE BRACKET(S):

Some installations require that you attach specific bracket(s). Using the supplied self tapping screws, secure the specified bracket(s) to the bosses on the back of the mounting panel.

EXAMPLE:

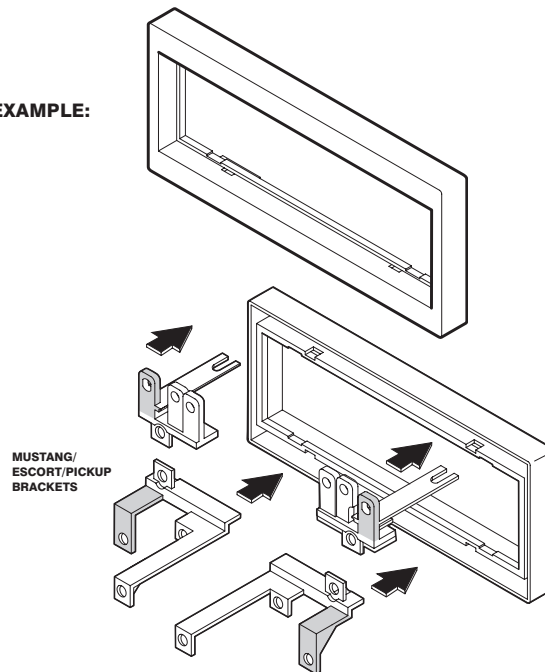

### CHRYSLER/DODGE/PLYMOUTH:

Kit panel is pre-assembled. Use the appropriate tabs that match your vehicle's mount locations. Brackets are not required.

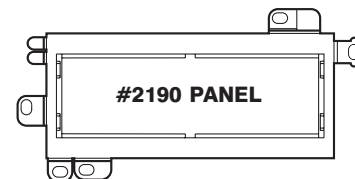

## QUICK START GUIDE

### STEP 5 RADIO ASSEMBLY

#### FLATFACE DIN/DETACHABLE FACEPLATE/PULLOUT (DIN-E) RADIOS

Slide the mounting sleeve (metal shroud) into the panel's radio opening and bend all available mounting tabs outward (see inset). Slide the radio into the mounting sleeve once it has been fastened to the kit panel until the radio locks into place.

**NOTE:** The mounting sleeve must be removed from the radio first! Your radio may be snapped into its sleeve. Slide the mounting sleeve (metal shroud) off the radio towards the back.

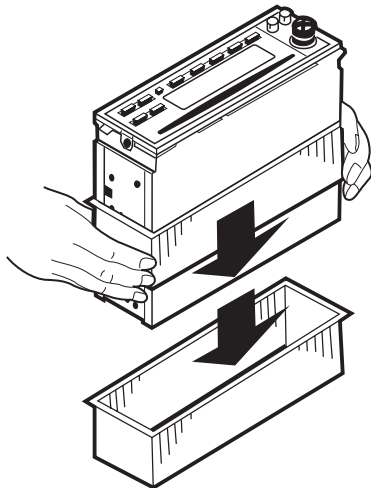
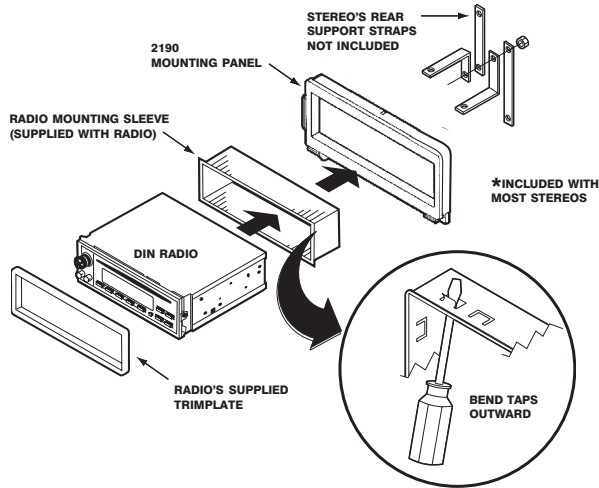

#### REMOVE SLEEVE FROM STEREO

1. Locate the locking mechanism on your DIN radio sleeve (typically) on the side.
2. Slip mounting sleeve towards rear of stereo and remove.

## QUICK START GUIDE

### STEP 6 RADIO ASSEMBLY (CONT'D)

#### SHAFT MOUNT RADIOS \*

Snap the shaft tabs (Part #1981) into the Radio opening as shown. Using the radio's faceplate and shaft nuts mount the Radio to the panel as shown.

**REAR SUPPORT BRACKET:**  
REAR SUPPORTING THE  
STEREO ADDS TO THE  
INSTALLATION'S  
STRUCTURAL INTEGRITY.

REAR SUPPORT  
STRAPS NOT  
INCLUDED

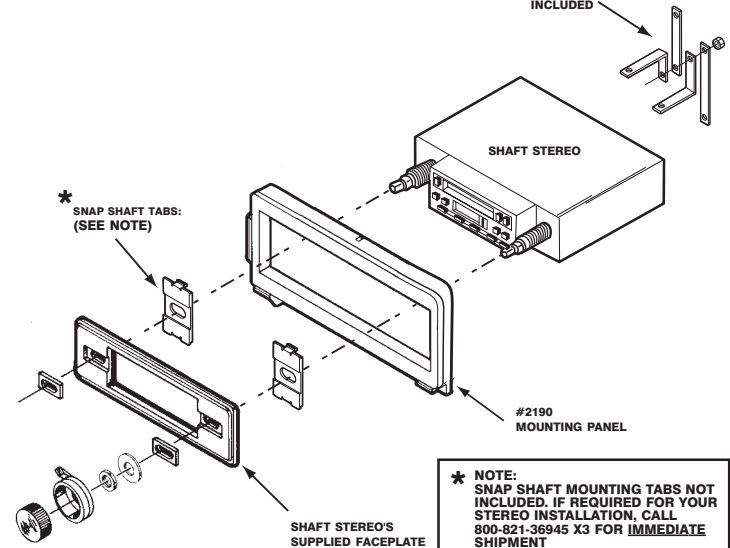

**\* NOTE:**  
SNAP SHAFT MOUNTING TABS NOT  
INCLUDED. IF REQUIRED FOR YOUR  
STEREO INSTALLATION, CALL  
800-821-36945 X3 FOR IMMEDIATE  
SHIPMENT

### STEP 7 CAR STEREO CONNECTORS

#### USING THE APPROPRIATE SCOSCHE WIRING CONNECTOR PROVIDED

Wire up your new aftermarket stereo to the Scosche wiring connector and install the Scosche kit and new stereo assembly to your vehicle. Then follow the dash disassembly for your specific vehicle in reverse order to reassemble your dash.

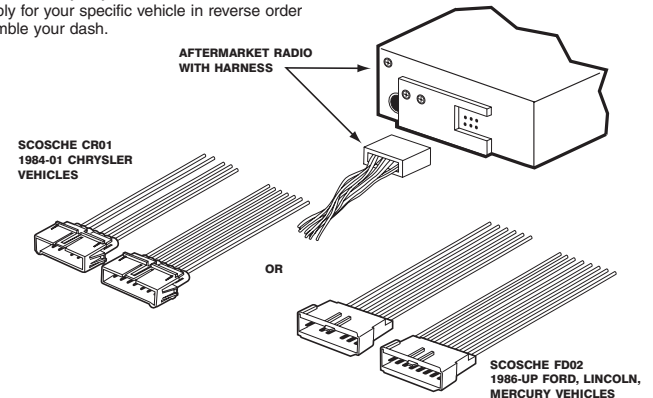

## FACTORY WIRING CODES

**NOTE:** The following connectors are available to easily plug your new stereo cassette/disc player into the factory harness:

### PART# DESCRIPTION:

**CR012** 1984-2005 Chrysler Vehicles  
**FD021** 1986-2004 Ford, Lincoln, Mercury Vehicles  
 Non Prem/JBL Sound

### PART# DESCRIPTION:

**IM01** 1990-Up Universal Import Vehicles  
**MA01** 1988-90 Mercury Tracer

**NOTE:**

- All wire codes are viewed as looking at the front of the plug with the wires exiting the rear.
- Use these wiring codes as a guide. Your vehicle might differ.

### 1984-2001 CHRYSLER VEHICLES

#### Gray Connector - Power/Speaker:

- 1 = 12 Volt Battery/Constant (12V+)
- 2 = 12 Volt Ignition/Switched (12V+)
- 3 = Radio Light
- 4 = Memory Light
- 5 = Right Front Negative (RF-)
- 6 = Left Front Negative (LF-)
- 7 = Not Used



#### Black Connector - Speaker:

- 1 = Right Rear Negative (RR-)
- 2 = Left Rear Negative (LR-)
- 3 = Right Front Positive (RF+)
- 4 = Left Front Positive (LF+)
- 5 = Right Rear Positive (RR+)
- 6 = Left Rear Positive (LR+)
- 7 = Power Antenna

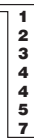

### 1986-UP FORD VEHICLES

#### Gray Connector - Power/Speaker:

- A = 12 Volt Battery/Constant (12V+)
- B = Not Used
- C = 12 Volt Ignition/Switched (12V+)
- D = Illumination
- E = LCD
- F = Chassis Ground (12V-)
- G = Power Antenna
- H = Remote Turn On (Factory Amplifier)



#### Black Connector - Speaker:

- A = Left Front Positive (LF+)
- B = Left Front Negative (LF-)
- C = Left Rear Positive (LR+)
- D = Left Rear Negative (LR-)
- E = Right Front Positive (RF+)
- F = Right Front Negative (RF-)
- G = Right Rear Positive (RR+)
- H = Right Rear Negative (RR-)



### 1982-86 FORD VEHICLES

#### Gray Connector - Speaker:

- 1 = Right Front Positive (RF+)
- 2 = Right Front Negative (RF-)
- 3 = Right Rear Positive (RR+)
- 4 = Right Rear Negative (RR-)
- 5 = Left Front Positive (LF+)
- 6 = Left Front Negative (LF-)
- 7 = Left Rear Positive (LR+)
- 8 = Left Rear Negative (LR-)

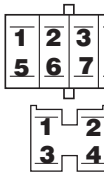

#### Gray Connector - Power:

- 1 = 12 Volt Accessory/Switched (12V+)
- 2 = 12 Volt Battery/Constant (12V+)
- 3 = Illumination/Dimmer (+12V Variable)
- 4 = Not Used

## 1999-04 Chrysler 300M 1999-01 Chrysler LHS 2001-04 Dodge Intrepid

**STOP** Read pages 2-6 for kit assembly.

### Radio Removal:

- Carefully pop up lower shifter console trim bezel and slide towards rear of car.
- Carefully pop out radio climate control panel, unplug connectors and remove.
- Extract four screws holding radio in, unplug and remove radio.

USE THESE SUPPORT TABS AS REQUIRED  
 Usar tantas de estas pestañas como sea necesario

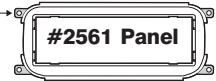

## 1995-00 Chrysler Cirrus 1996-00 Chrysler Sebring "JXI" Convertible

**STOP** Read pages 2-6 for kit assembly.

### 1995-01 Dodge Stratus

### 1996-00 Plymouth Breeze

### Radio Removal:

- Carefully pry out on the radio/heater control trim bezel, unplug and remove.
- Extract two 3/8" bolts holding radio in, unplug and remove radio.

**NOTE:** The rear of the aftermarket stereo should be supported.

USE THESE SUPPORT TABS AS REQUIRED  
 Usar tantas de estas pestañas como sea necesario

USE THIS BRACKET  
 Usar este braquete



REMOVE ALIGNMENT PIN - TOP  
 Quitar la clavija de alineamiento - Superior

## 1998-04 Chrysler Concorde

**STOP** Read pages 2-6 for kit assembly.

### Radio Removal:

- Carefully pop out radio/climate control bezel, unplug and remove.
- Extract four screws holding radio in, unplug and remove radio.

USE THESE SUPPORT TABS AS REQUIRED  
 Usar tantas de estas pestañas como sea necesario

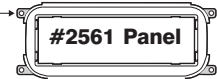

## 1993-97 Chrysler Concorde 1993-00 Dodge Intrepid 1993-97 Eagle Vision

**STOP** Read pages 2-6 for kit assembly.

### Radio Removal:

- Pull the radio trim bezel out to release the snap clips, and remove the bezel.
- Extract the two bolts securing the radio, pull the radio from the cavity, unplug all connectors and remove the radio.

USE THESE SUPPORT TABS AS REQUIRED  
 Usar tantas de estas pestañas como sea necesario

USE THIS BRACKET  
 Usar este braquete



REMOVE ALIGNMENT PIN - BOTTOM  
 Sacar la clavija de alineamiento - Inferior

## 1980-83 Chrysler Cordoba 1980-83 Dodge Mirada

**STOP** Read pages 2-6  
for kit assembly.

### Radio Removal:

1. Remove four screws securing the radio dash panel: two above the radio and two above the heater controls.
2. Remove the radio dash panel. Remove two screws securing the radio to the dash. Pull the radio out.
3. Disconnect power, antenna, and all speaker and electrical connections.

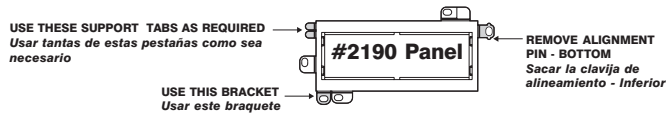

## 1975-79 Chrysler Cordoba 1975-79 Plymouth Fury

**STOP** Read pages 2-6  
for kit assembly.

### Radio Removal:

1. Remove four securing screws from the bottom edge of the radio dash panel.
2. Remove two securing screws from the top edge of the panel above the radio.
3. Unscrew the retainer ring securing the remote mirror control and remove the panel.
4. Remove two screws securing radio to the dash. Pull the radio out.
5. Disconnect power, antenna and all speaker and electrical connections.

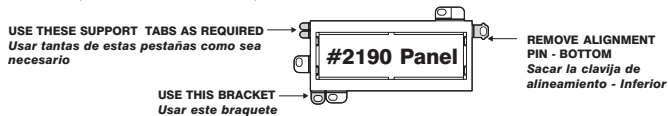

## 1983-84 Chrysler E Class 1984-88 Chrysler Le Baron 1984-87 Chrysler New Yorker 1983-88 Dodge 600 ES 1985-89 Dodge Aries

**STOP** Read pages 2-6  
for kit assembly.

### Radio Removal:

1. Remove nine securing screws from the top and bottom of the radio trim panel. Remove the panel by pulling it down and out.
2. Unhook the wiring harness.
3. Remove the two Chrysler anti-theft bolts retaining the radio (use Snap-On bit TTW 12 for 1/4" drive) and remove the radio. Disconnect power, ground cable, antenna and speaker wires.

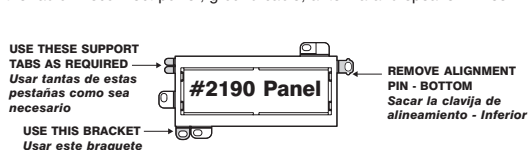

## 1990-93 Chrysler Fifth Avenue/ Imperial

**STOP** Read pages 2-6  
for kit assembly.

## 1988-93 Chrysler New Yorker 1988-93 Dodge Dynasty

### Radio Removal:

1. Remove five screws from along the top side of the radio/instrument panel dash trim.
2. Lower the steering column, place the gear selector in drive, then remove the trim panel.
3. Remove two bolts securing the radio, and pull the radio out, disconnect wire harnesses, ground strap and antenna lead, then remove the radio.

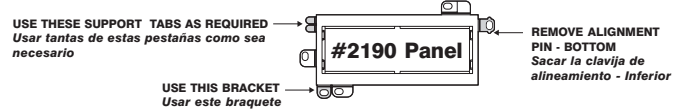

## 1979-89 Chrysler Imperial 1979-81 Chrysler Newport 1979-83 Chrysler New Yorker 1979-81 Dodge St. Regis

**STOP** Read pages 2-6  
for kit assembly.

### Radio Removal:

1. Remove four screws securing the radio dash panel: two above the radio and two above the heater controls.
2. Remove radio dash panel.
3. Remove two screws securing the radio to the dash. Pull the radio out.
4. Disconnect power, antenna, and all speaker and electrical connections.

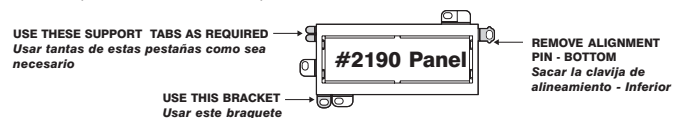

## 1984-86 Chrysler Laser 1984-89 Dodge Daytona

**STOP** Read pages 2-6  
for kit assembly.

### Radio Removal:

1. Remove one screw from each side of the ashtray.
2. Pull off the trim panel.
3. Remove two screws securing the radio to the dash. Pull the radio out.
4. Disconnect the power, antenna, and all speaker and electrical connections.

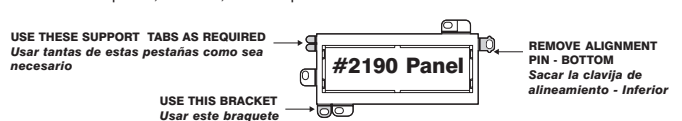

**1982-83 Chrysler Le Baron**  
**1981-84 Dodge Aries**  
**1982-83 Dodge 400**

**STOP** Read pages 2-6  
for kit assembly.

**Radio Removal:**

1. Remove four screws from the top of the radio panel trim and four from the bottom of the panel trim. Remove the panel.
2. Remove two bolts retaining the radio, and remove the radio. Disconnect the power, ground cable, antenna and speaker wires.

USE THESE SUPPORT TABS AS REQUIRED  
Usar tantas de estas pestañas como sea necesario

USE THIS BRACKET  
Usar este braquete



REMOVE ALIGNMENT  
PIN - BOTTOM  
Sacar la clavija de  
alineamiento - Inferior

**1977-81 Chrysler Le Baron**  
**1979-89 Chrysler Fifth Avenue**  
**1977-89 Dodge Diplomat**  
**1978-89 Plymouth Gran Fury**

**STOP** Read pages 2-6  
for kit assembly.

**Radio Removal:**

1. Remove four screws from the top edge of the dash panel and four screws from the bottom edge. Remove the panel.
2. Remove two screws securing the radio to the dash and pull out.
3. Disconnect power, antenna, and all speaker, and electrical connections

USE THESE SUPPORT TABS AS REQUIRED  
Usar tantas de estas pestañas como sea necesario

USE THIS BRACKET  
Usar este braquete

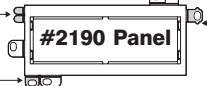

REMOVE ALIGNMENT  
PIN - BOTTOM  
Sacar la clavija de  
alineamiento - Inferior

**1987-93 Chrysler Le Baron "Coupe"**

**STOP** Read pages 2-6  
for kit assembly.

**Radio Removal:**

1. Remove two screws, one from each lower corner of the radio/console trim panel.
2. Gently snap off the trim panel.
3. Remove two screws securing the right side panel of the console, one at top, one at bottom; remove the side panel.
4. Remove two screws from the radio mounting bracket. Disconnect the wire harness, antenna lead, and ground strap. Remove the radio.

USE THESE SUPPORT TABS AS REQUIRED  
Usar tantas de estas pestañas como sea necesario

USE THIS BRACKET  
Usar este braquete



REMOVE ALIGNMENT  
PIN - BOTTOM  
Sacar la clavija de  
alineamiento - Inferior

**1990-95 Chrysler Le Baron GTC**

**STOP** Read pages 2-6  
for kit assembly.

**Radio Removal:**

1. Gently pry outward on the radio trim bezel to release seven snap clips and remove.
2. Extract two hex head bolts holding radio in place and slide radio outward.
3. Unplug all power/speaker connectors, unplug antenna and unbolt ground strap-remove radio.

USE THESE SUPPORT TABS AS REQUIRED  
Usar tantas de estas pestañas como sea necesario

USE THIS BRACKET  
Usar este braquete

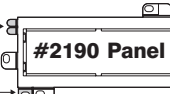

REMOVE ALIGNMENT  
PIN - BOTTOM  
Sacar la clavija de  
alineamiento - Inferior

**1985-89 Chrysler Le Baron GTS**  
**1985-89 Dodge Lancer**

**STOP** Read pages 2-6  
for kit assembly.

**Radio Removal:**

1. Remove eleven screws from the perimeter of the dashtrim panel and remove the trim panel.
2. Remove two anti-theft bolts (use Snap-On bit TTW12 for 1/4" drive) which secure the radio to the dash substructure; pull the radio out of the cavity, disconnect all wiring, and remove the radio.

USE THESE SUPPORT TABS AS REQUIRED  
Usar tantas de estas pestañas como sea necesario

USE THIS BRACKET  
Usar este braquete



REMOVE ALIGNMENT  
PIN - BOTTOM  
Sacar la clavija de  
alineamiento - Inferior

**1989-94 Chrysler Le Baron Landau**

**STOP** Read pages 2-6  
for kit assembly.

**Radio Removal:**

1. Starting from the bottom, gently pry outward on the radio trim bezel to release the two spring clips on the bottom and three across the top.
2. Unplug the lamp harness from the back of the trim bezel and remove.
3. Extract two screws above radio, one at the lower right corner behind glove box door, and one screw at the lower right hand corner below steering column.
4. Remove the trim panel around the radio itself.
5. Extract two hex head screws holding radio in place, unplug all connectors and unbolt ground strap.
6. Remove radio.

USE THESE SUPPORT TABS AS REQUIRED  
Usar tantas de estas pestañas como sea necesario

USE THIS BRACKET  
Usar este braquete

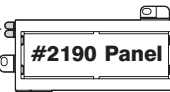

REMOVE ALIGNMENT  
PIN - BOTTOM  
Sacar la clavija de  
alineamiento - Inferior

**1994-97 Chrysler LHS**  
**1994-96 Chrysler New Yorker**



**Radio Removal:**

1. Remove the ashtray from the dash.
2. Carefully pry out on the perimeter radio dash bezel using a panel removal tool to release the fastening clips and remove the radio dash bezel.
3. Extract the two screws securing the radio to the dash, pull the radio from the dash cavity, unplug all connectors and remove the radio.

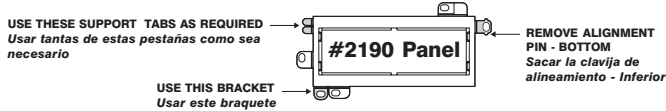

**1995-00 Chrysler Sebring**  
**1995-00 Dodge Avenger**



**Radio Removal:**

1. Carefully pry out on radio/AC control trim bezel to release the snap clips. Remove the bezel.
2. Extract the two screws holding radio in, unplug connector, unbolt ground wire from rear of radio and remove radio.

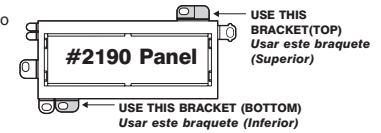

**1975-78 Chrysler Newport, New Yorker**  
**1975-79 Dodge Royal Monaco**  
**1975-77 Plymouth Gran Fury**



**Radio Removal:**

1. Remove three screws from the bottom edge of the dash panel.
2. Remove the ashtray and remove one screw retaining the dash panel.
3. Disconnect the cigarette lighter and wiper wires.
4. Pull the dash panel out from the top. Place the gear selector in low gear and remove the dash panel.
5. Release the radio rear support. Remove two screws securing the radio to the dash. Pull the radio out.
6. Disconnect the power, antenna, and all speaker and electrical connections.

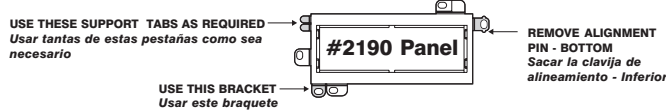

**2001-05 Chrysler Sebring Convertible**  
**2000-06 Chrysler Sebring, 4-Dr. Sedan**  
**2002-06 Dodge Stratus Sedan**



**Radio Removal:**

**NOTE:** The factory radio provision is a DIN and a half opening.

1. Use panel removal tool to pry out radio dash bezel.
2. Disconnect and remove bezel.
3. Extract four Philips head screws from radio.
4. Pull radio away, disconnect and remove.

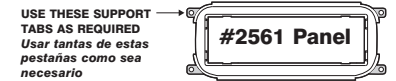

**2001-05 Chrysler Sebring, Coupe**  
**2002-06 Dodge Stratus Coupe**



**Radio Removal:**

1. Extract two Philips head screws from bottom of radio bezel.
2. Using a panel removal tool, unsnap and remove the dash bezel.
3. Extract four Philips head screws securing radio; lift away, disconnect, and remove.

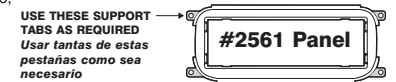

**2000-05 Chrysler PT Cruiser**



**Radio Removal:**

1. Using a small pick tool, unsnap power window control. Extract (1) Phillips head screw from behind, lift away, disconnect and remove.
2. Using a panel removal tool, carefully remove dash bezel.
3. Extract (4) Phillips head screws securing radio, lift away, disconnect and remove.

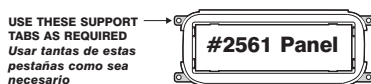

**2001-06 Chrysler Town & Country**  
**2001-06 Dodge Caravan**



**Radio Removal:**

1. Open drink holder and remove screw cover panel at bottom of radio bezel, extract (2) Phillips head screws from behind.
2. Using a panel removal tool, unsnap, disconnect, and remove the dash bezel.
3. Extract four Phillips head screws securing radio, lift away, disconnect, and remove.

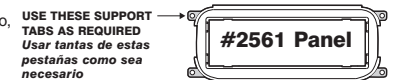

**1996-00 Chrysler Town & Country**  
**1996-00 Dodge Caravan**  
**1996-00 Plymouth Voyager**



**Radio Removal:**

1. Extract two screws in the trim bezel from just above the radio.
2. Pop off small trim below radio and extract (2) screws from behind.
3. Pull the radio trim bezel away from the dash, unplug the ac/heating control.
4. Extract the two screws securing the radio to the dash, pull the radio from the cavity, disconnect the ground strap, unplug all connectors and remove the radio.



**1991-93 Chrysler Town & Country**  
**1991-93 Dodge Caravan**  
**1991-93 Plymouth Voyager**



**Radio Removal:**

1. Remove the cigarette lighter.
2. Using a panel removal tool, carefully pry outward to release the clips securing the dash bezel and remove the bezel.
3. Extract the two screws securing the rear hatch switch to the dash bezel.
4. Extract the two 3/8" bolts securing the radio to the dash.
5. Pull the radio out of the dash, and unplug all the connectors. Disconnect the ground strap and remove the radio.

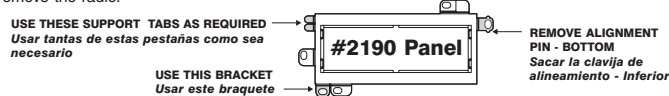

**1994-95 Chrysler Town & Country**  
**1994-95 Dodge Caravan**  
**1994-95 Plymouth Voyager**



**Radio Removal:**

1. Using a panel removal tool carefully pry up on the dash panel at the base of the windshield (speaker grille panel) to release the fastening clips securing it to the dash and pull out on the panel to remove.
2. Pry up the piece of trim that looks like a vent in front of the instrument light cluster on top of the dash using a panel removal tool to release and remove the trim.
3. Carefully pry out on the trim panel surrounding the heater controls using a panel removal tool to release the fastening clips securing the trim to the dash and remove the trim.
4. Extract the three screws securing the bottom of the radio trim bezel to the dash.
5. Extract the three screws securing the front of the instrument light cluster to the top of the dash.
6. Extract the screw securing the back of the instrument light cluster to the dash, pry up on the light cluster with a panel removal tool, unplug all connectors and remove.
7. Extract the three screws securing the top of the radio trim bezel to the dash on the drivers side of the dash.
8. Pull the radio trim bezel away from the dash, unplug all connectors, shift the gear select lever into low, tilt the steering wheel down and remove the bezel.
9. Extract the two screws securing the radio to the dash, pull the radio from the cavity, disconnect the ground strap unplug all connectors and remove the radio.

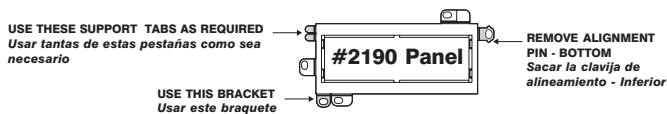

**1990 Chrysler Town & Country**  
**1984-90 Dodge Caravan**  
**1984-90 Plymouth Voyager**



**Radio Removal:**

1. Reach behind ashtray and unsnap the carrier housing to remove the ashtray.
2. Remove three screws along the top edge of the radio trim panel.
3. Remove two screws below the radio trim panel. Remove the trim panel.
4. Remove two screws securing the radio to dash then pull the radio out.
5. Disconnect the power, antenna, and all speaker and electrical connections. Remove the radio.



**1979-82 Dodge 024**  
**1979-87 Dodge Charger**  
**1978-90 Dodge Omni**  
**1982-84 Dodge Rampage** **1978-90 Plymouth Horizon**  
**1983-90 Plymouth Scamp** **1979-82 Plymouth TC3**  
**1983-87 Plymouth Turismo**



**Radio Removal:**

1. Remove seven screws from the top and bottom edges of the radio dash panel and remove the panel.
2. Remove two screws securing the radio to the dash and pull the radio out.
3. Disconnect power, antenna, and all speaker and electrical connections.

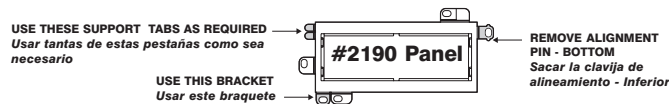



## 1976-80 Dodge Aspen 1976-80 Plymouth Volare



### Radio Removal:

1. Remove four screws from the bottom of the dash panel. Carefully pull the top portion of the panel out and remove the radio.
2. Remove two screws securing the radio to the dash and pull the radio out.
3. Disconnect power, antenna, and all speaker electrical connections.

USE THESE SUPPORT TABS AS REQUIRED  
Usar tantas de estas pestañas como sea necesario

USE THIS BRACKET  
Usar este braquete

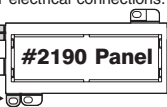

REMOVE ALIGNMENT PIN - BOTTOM  
Sacar la clavija de alineamiento - Inferior

## 1974-78 Dodge Charger, Monaco 1978-79 Dodge Magnum XE



### Radio Removal:

1. Remove four screws from the bottom edge of the radio dash panel.
2. Remove two screws from the top edge of the panel above the radio location.
3. Unscrew the retainer ring securing the remote mirror control and remove the panel.
4. Remove two screws securing the radio to the dash. Pull the radio out.
5. Disconnect power, antenna, and all speaker and electrical connections.

USE THESE SUPPORT TABS AS REQUIRED  
Usar tantas de estas pestañas como sea necesario

USE THIS BRACKET  
Usar este braquete



REMOVE ALIGNMENT PIN - BOTTOM  
Sacar la clavija de alineamiento - Inferior

## 2001-04 Dodge Dakota Extra Cab 2001-03 Dodge Durango



### Radio Removal:

1. Extract two Phillips screws from top of instrument cluster.
2. Extract three T-20 torx screws from bottom of dash panel and pull down.
3. Using panel removal tool, carefully pry out dash bezel, disconnect, and remove.
4. Extract four Phillips screws securing radio, disconnect, and remove.

USE THESE SUPPORT TABS AS REQUIRED  
Usar tantas de estas pestañas como sea necesario

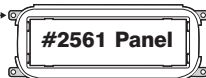

## 1998-00 Dodge Dakota 1998-00 Dodge Durango



### Radio Removal:

1. Extract three screws from the bottom edge of small center plastic panel below steering column, pry out on panel to remove.
2. Use a panel removal tool to carefully pry out on the radio/dash panel, unplug, unplug the left side of the panel, and remove.
3. Extract two 10MM bolts holding radio in, unplug and remove radio.

USE THESE SUPPORT TABS AS REQUIRED  
Usar tantas de estas pestañas como sea necesario

USE THIS BRACKET  
Usar este braquete



REMOVE ALIGNMENT PIN - BOTTOM  
Sacar la clavija de alineamiento - Inferior

## 1987-96 Dodge Dakota



### Radio Removal:

1. Remove eight screws from the dash trim panel.
2. Remove two screws from the underside of the steering column trim, and remove the rim.
3. Remove two screws from the radio mounting bracket, disconnect power antenna, speaker leads, and all other electrical connections, and remove the radio.

USE THESE SUPPORT TABS AS REQUIRED  
Usar tantas de estas pestañas como sea necesario

USE THIS BRACKET  
Usar este braquete

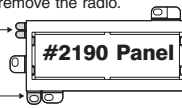

REMOVE ALIGNMENT PIN - BOTTOM  
Sacar la clavija de alineamiento - Inferior

## 1990-93 Dodge Daytona



### Radio Removal:

1. Pull firmly outward on the console/radio trim panel - secured by five metal spring clips, two at the top, two on the right side and one on the left side.
2. Extract the top two screws from each side of the lower console - this allows you to slightly spread the console, providing clearance to remove the radio.
3. Remove the remaining two screws securing the radio, disconnect the connectors and remove the radio.

USE THESE SUPPORT TABS AS REQUIRED  
Usar tantas de estas pestañas como sea necesario

USE THIS BRACKET  
Usar este braquete



REMOVE ALIGNMENT PIN - BOTTOM  
Sacar la clavija de alineamiento - Inferior

## 2000-05 Dodge Neon 2000-01 Plymouth Neon



### Radio Removal:

1. Rotate vents until they unplug, lift away and remove. Extract (2) screws from behind.
2. Remove temperature control knobs.
3. Unsnap bezel, lift away and remove.
4. Extract four screws holding radio in, unplug and remove radio.

USE THESE SUPPORT TABS AS REQUIRED  
Usar tantas de estas pestañas como sea necesario

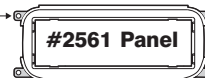

## 1995-99 Dodge Neon 1995-99 Plymouth Neon



### Radio Removal:

1. Remove the ashtray from the dash.
2. Carefully pry outward on the radio trim bezel to release spring clips then remove.
3. Extract the two 3/8" screws securing the radio to the dash, pull the radio from the dash cavity, unplug all connectors, disconnect the ground strap and remove the radio.

USE THESE SUPPORT TABS AS REQUIRED  
Usar tantas de estas pestañas como sea necesario

USE THIS BRACKET  
Usar este braquete

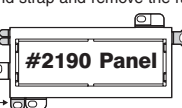

REMOVE ALIGNMENT PIN - BOTTOM  
Sacar la clavija de alineamiento - Inferior

## 1981-93 Dodge Pickup, Ramcharger 1981-93 Plymouth Trailduster



### Radio Removal:

1. Remove five screws from the edge of the dash panel.
2. Remove one screw from the dash panel above the radio.
3. Carefully pull out the bottom of the panel to release the panel clips and remove the panel.
4. Remove two screws securing the radio to the dash and pull out the radio.
5. Disconnect the power, antenna, and all speaker and electrical connections.

USE THESE SUPPORT TABS AS REQUIRED  
Usar tantas de estas pestañas como sea necesario

USE THIS BRACKET  
Usar este braquete



REMOVE ALIGNMENT PIN - BOTTOM  
Sacar la clavija de alineamiento - Inferior

## 1974-80 Dodge Pickup, Ramcharger 1974-80 Plymouth Trailduster



### Radio Removal:

1. Remove four screws from the top edge of the dash panel.
2. Remove seven screws on the front surface and three under the dash panel.
3. Carefully pull the panel from the dash and remove it.
4. Remove two screws securing the radio to the dash. Pull the radio out.
5. Disconnect the power, antenna, and all speaker and electrical connections.

USE THESE SUPPORT TABS AS REQUIRED  
Usar tantas de estas pestañas como sea necesario

USE THIS BRACKET  
Usar este braquete

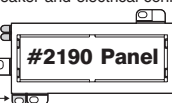

REMOVE ALIGNMENT PIN - BOTTOM  
Sacar la clavija de alineamiento - Inferior

## 2002-05 Dodge Ram



### Radio Removal:

1. Extract one Philips head screw from below passenger side vent.
2. Extract two Philips head screws securing knee panel and remove.
3. Use fingers to pull top of trim bezel out then pry out bottom, securing radio, disconnect, and remove.

USE THESE SUPPORT TABS AS REQUIRED  
Usar tantas de estas pestañas como sea necesario

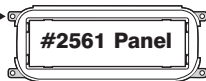

## 1998-01 Dodge Ram



### Radio Removal:

1. Extract one Screw from lighter socket area.
2. Carefully pry out on the radio dash bezel to release the fastening clips, disconnect all connectors and remove the bezel.
3. Extract the two screws securing the radio to the dash, pull the radio from the dash cavity, unplug all connectors, disconnect the ground strap and remove the radio.

USE THESE SUPPORT TABS AS REQUIRED  
Usar tantas de estas pestañas como sea necesario

USE THIS BRACKET  
Usar este braquete

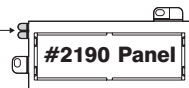

REMOVE ALIGNMENT PIN - BOTTOM  
Sacar la clavija de alineamiento - Inferior

## 1994-97 Dodge Ram



### Radio Removal:

1. Remove two screws securing the dash panel inside the glove box.
2. Remove four screws from the bottom edge of the dash panel and one on the left side of the panel.
3. Carefully pull the panel from the dash and remove the panel.
4. Remove two screws securing the radio to the dash. Pull the radio out.
5. Disconnect power, antenna, and all speaker and electrical connections.

USE THESE SUPPORT TABS AS REQUIRED  
Usar tantas de estas pestañas como sea necesario

USE THIS BRACKET  
Usar este braquete



REMOVE ALIGNMENT PIN - BOTTOM  
Sacar la clavija de alineamiento - Inferior

## 1987-94 Dodge Shadow 1987-94 Plymouth Sundance



### Radio Removal:

1. Remove the ashtray
2. Carefully pull outward on the edges of the trim panel to release the snaps, and remove the panel.
3. Remove one retaining screw from above the right upper corner of the radio.
4. Pull the dash trim towards the passenger side to gain access to the upper right radio bolt; remove the top right bolt and the lower left bolt.
5. Pull out the radio. Disconnect the power, antenna, speaker leads, and all other electrical connections. Remove the radio.

USE THESE SUPPORT TABS AS REQUIRED  
Usar tantas de estas pestañas como sea necesario

USE THIS BRACKET  
Usar este braquete



REMOVE ALIGNMENT PIN - BOTTOM  
Sacar la clavija de alineamiento - Inferior

## 1989-95 Dodge Spirit



### Radio Removal:

1. Carefully release the spring type fasteners from the radio/console trim panel - three from along the top and two from the bottom of the panel.
2. Remove two screws from along the top of the side console trim pieces, and spread the side piece out slightly for access to the radio bolt.
3. After spreading the side piece, extract the top right radio mounting bolt, then remove the bottom left bolt.
4. Spread the side piece once again to provide clearance for pulling the radio out of the cavity; pull the radio out, disconnect the connectors, and remove the radio.

USE THESE SUPPORT TABS AS REQUIRED  
Usar tantas de estas pestañas como sea necesario

USE THIS BRACKET  
Usar este braquete



REMOVE ALIGNMENT PIN - BOTTOM  
Sacar la clavija de alineamiento - Inferior

## 2001 Dodge Stratus

### Radio Removal:

1. Using panel removal tool, carefully pry out the bezel, disconnect, and remove.
2. Extract four Philips head screws securing radio, disconnect, and remove.

USE THESE SUPPORT TABS AS REQUIRED  
Usar tantas de estas pestañas como sea necesario



## 1978-02 Dodge Van 1978-83 Plymouth Van

### Radio Removal:

1. Remove the ashtray from the dash, extract the two screws securing the ashtray bracket to the dash and remove the bracket.
2. Open up the cup holder and extract the two screws securing it to the dash.
3. Carefully pry out on the perimeter radio dash bezel using a panel removal tool to release the fastening clips, disconnect all connectors and remove the bezel.
4. Extract the two screws securing the radio to the dash, pull the radio from the dash cavity, unplug all connectors, disconnect the ground strap and remove the radio.

USE THESE SUPPORT TABS AS REQUIRED  
Usar tantas de estas pestañas como sea necesario

USE THIS BRACKET  
Usar este braquete



REMOVE ALIGNMENT PIN - BOTTOM  
Sacar la clavija de alineamiento - Inferior

## 1983-88 Ford Bronco II 1983-88 Ford Ranger



### Radio Removal:

1. Remove the knobs from the radio.
2. Remove four screws from the top leading edge of the instrument cluster trim panel. Carefully pry the top edge loose.
3. Carefully pry out the trim strip below the dash pocket, right and left of the ashtray strip.
4. Depress the spring clip behind light switch knob and remove knob. Carefully pry out the trim strip from this location.
5. Remove the remaining four screws from the bottom edge of the instrument cluster trim panel and remove the panel.

**NOTE:** If the truck is not equipped with a radio unscrew the dummy plate covering the radio openings in the trim panel.

6. Remove four screws securing the radio assembly to the dash. Pull the radio out. Disconnect the power, antenna, and all speaker and electrical connections.

USE THESE SUPPORT TABS AS REQUIRED  
Usar tantas de estas pestañas como sea necesario

USE THIS BRACKET  
Usar este braquete

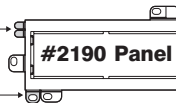

REMOVE ALIGNMENT PIN - BOTTOM  
Sacar la clavija de alineamiento - Inferior

## 1987-91 Ford Bronco Full Size 1987-91 Ford F-Series Pickup



### Radio Removal:

1. Firmly pull on the edges of the radio trim panel to release the trim panel clips and remove the panel.
2. Remove four screws from the radio mounting bracket. Slide the radio out of the dash, disconnect the wiring harnesses, and remove the radio.
3. Secure the radio/kit assembly to the dash using the four screws removed earlier.
4. Reassemble dash by reversing steps in the radio removal.

## 1985-91 Ford Aerostar

### Radio Removal:

1. Remove two screws from the bottom edge of the radio trim panel.
2. Pull down two snaps above the air-conditioning outlet vents and remove the radio trim panel.
3. Pull out the radio. Remove four screws from the radio mounting bracket; disconnect the wiring, and remove the radio.

USE THESE SUPPORT TABS AS REQUIRED  
Usar tantas de estas pestañas como sea necesario

USE THIS BRACKET  
Usar este braquete



REMOVE ALIGNMENT PIN - BOTTOM  
Sacar la clavija de alineamiento - Inferior

## 1980-86 Ford Bronco - Pickup

### Radio Removal:

1. Remove knobs from radio when vehicle is equipped with a radio.
2. Remove two screws from the top of the radio panel. Pull the top out and up to release the tabs on the bottom of the panel.
3. Remove four screws from the radio mounting bracket. Remove the assembly.
4. Disconnect the power, antenna, and all speaker and electrical connections.

USE THESE SUPPORT TABS AS REQUIRED  
Usar tantas de estas pestañas como sea necesario

USE THIS BRACKET  
Usar este braquete



REMOVE ALIGNMENT PIN - BOTTOM  
Sacar la clavija de alineamiento - Inferior

## 1975-91 Ford E150/E250/E350 Van



### Radio Removal:

1. Remove the knobs and the shaft nuts from the radio.
2. Remove six screws from the dash panel.
3. Remove the panel and disconnect the cigarette lighter.
4. Remove four screws securing the radio mounting bracket to the dash. Release the rear support and remove the assembly.
5. Disconnect the power, antenna, and all speaker and electrical connections.

USE THESE SUPPORT TABS AS REQUIRED  
Usar tantas de estas pestañas como sea necesario

USE THIS BRACKET  
Usar este braquete



REMOVE ALIGNMENT PIN - BOTTOM  
Sacar la clavija de alineamiento - Inferior

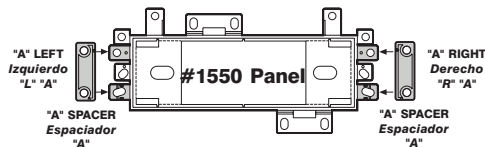

**1984-90 Ford Escort**  
**1984-88 Ford EXP**  
**1984-87 Mercury Lynx**



Read pages 2-6  
for kit assembly.

**Radio Removal:**

1. Remove six screws from the radio trim panel. Remove the panel.
2. Remove four screws securing the radio/bracket assembly.
3. Pull the radio out of the cavity, and disconnect the antenna and all speaker and electrical connections. Remove the radio.

USE THESE SUPPORT TABS AS REQUIRED  
Usar tantas de estas pestañas como sea necesario



REMOVE ALIGNMENT  
PIN - BOTTOM  
Sacar la clavija de  
alineamiento - Inferior

USE THIS BRACKET  
Usar este braquete

**1986-89 Ford Taurus**



Read pages 2-6  
for kit assembly.

**Radio Removal:**

1. Remove two screws from the bottom of the radio trim panel.
2. Carefully pry on the edges of the trim panel to release the plastic clips and pull the panel away from the dash.
3. Disconnect the power wire for the antenna switch and remove the radio trim panel.
4. Remove four screws from the radio mounting brackets, slide the radio out from the dash, disconnect all electrical, and remove the radio.

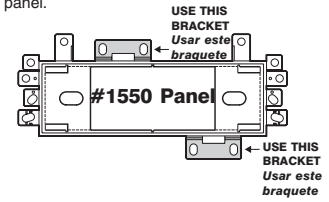

USE THIS  
BRACKET  
Usar este  
braquete

USE THIS  
BRACKET  
Usar este  
braquete

**1983-85 Ford LTD**  
**1984-88 Mercury Marquis**



Read pages 2-6  
for kit assembly.

**Radio Removal:**

1. Remove the radio knobs.
2. Open the ashtray and remove two screws from the top of the ash tray cavity.
3. Remove the radio trim panel by pulling out the bottom of the panel and sliding the panel over the ashtray face.
4. Remove four screws from the radio mounting plate (shaft support plate). Pull the radio out of the cavity, and disconnect the two wiring harnesses, speakers and antenna lead. Remove the radio.

USE THESE SUPPORT TABS AS REQUIRED  
Usar tantas de estas pestañas como sea necesario



REMOVE ALIGNMENT  
PIN - BOTTOM  
Sacar la clavija de  
alineamiento - Inferior

USE THIS BRACKET  
Usar este braquete

**1985-86 Ford Mustang**  
**1985-86 Mercury Capri**



Read pages 2-6  
for kit assembly.

**Radio Removal:**

1. Open the armrest glove box and remove four screws in the bottom of the glove box.
2. Remove two screws at the forward edge securing the hand brake trim. Remove the trim.  
**NOTE:** There may be two additional screws below this trim on some cars.
3. Unsnap the gear lever trim from the front, slide it forward, and remove it.
4. Open the ashtray and remove one screw from each side. Pull the ashtray/lighter trim up and disconnect the wires.
5. Remove four screws from below the ashtray and pull the console up. Disconnect the wiring harness and remove the console.
6. Remove two screws above the radio face and one screw from below the radio. Pull out the radio and disconnect the wires, then slide the radio towards the front of the car and out the back of the cavity.

USE THESE SUPPORT TABS AS REQUIRED  
Usar tantas de estas pestañas como sea necesario



REMOVE ALIGNMENT  
PIN - BOTTOM  
Sacar la clavija de  
alineamiento - Inferior

USE THIS BRACKET  
Usar este braquete

**1983-89 Ford Crown Victoria**  
**1983-89 Mercury Grand Marquis**



Read pages 2-6  
for kit assembly.

**Radio Removal:**

1. Remove four screws from the radio trim panel: two inside the ashtray, and two from the top of the panel.
2. Remove the radio's knobs; pull the trim panel out from the bottom and remove it.
3. Remove four screws securing the radio mounting brackets to the dash, and pull the assembly out.
4. Disconnect the power, antenna, and all speaker and electrical connections.

USE THESE SUPPORT TABS AS REQUIRED  
Usar tantas de estas pestañas como sea necesario



REMOVE ALIGNMENT  
PIN - BOTTOM  
Sacar la clavija de  
alineamiento - Inferior

USE THIS BRACKET  
Usar este braquete

**1984-87 Ford Tempo**  
**1984-87 Mercury Topaz**



Read pages 2-6  
for kit assembly.

**Radio Removal:**

1. Remove two screws securing the trim panel below the steering column. Carefully unsnap the trim panel and remove it.
2. Remove three screws along the upper edge of the dash panel: two screws below the radio, and one screw from the dash pocket.
3. Using a thin blade screwdriver, carefully push up two retaining clips, one on each side of the steering column, and slide the dash panel up and off.
4. Remove four screws retaining the radio bracket assembly and remove the radio. Disconnect the power, antenna, and speaker wires.

USE THESE SUPPORT TABS AS REQUIRED  
Usar tantas de estas pestañas como sea necesario



REMOVE ALIGNMENT  
PIN - BOTTOM  
Sacar la clavija de  
alineamiento - Inferior

USE THIS BRACKET  
Usar este braquete

## 1984-89 Lincoln Town Car

### Radio Removal:

1. Remove three screws from the radio trim below the dash.
2. Open out the 1-1/2" wide plastic trim piece above the radio trim.
3. Remove three screws from behind the trim. Remove the instrument cluster trim panel.
4. Remove three screws which secure the radio and the radio brackets to dash.
5. Disconnect the two wiring harnesses, antenna lead, and harness retaining clip. Remove the radio.

USE THESE SUPPORT TABS AS REQUIRED  
Usar tantas de estas pestañas como sea necesario

USE THIS BRACKET  
Usar este braquete

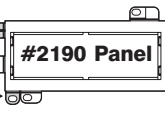

REMOVE ALIGNMENT PIN - BOTTOM  
Sacar la clavija de alineamiento - Inferior



Read pages 2-6  
for kit assembly.

## 1986-89 Mercury Sable

### Radio Removal:

1. Carefully pull on the edges of the radio trim panel to release the plastic clips, and remove the trim panel.
2. Remove four screws which secure the radio to the dashboard, slide the radio out of the dash, disconnect the harnesses and antenna, then remove radio.

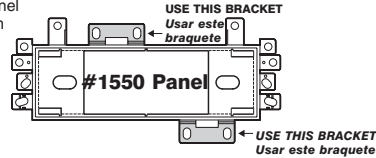

USE THIS BRACKET  
Usar este braquete

USE THIS BRACKET  
Usar este braquete



Read pages 2-6  
for kit assembly.

## 1988-90 Mercury Tracer

### Radio Removal:

1. Remove three screws from the underside of the upper lip of the radio/console trim panel.
2. Remove ashtray and remove two screws from inside the ashtray cavity.
3. Gently unsnap the trim panel, disconnect the wiring and remove the panel.
4. Remove four screws securing the radio pull the radio out of the cavity and disconnect the wiring, and remove the radio.

USE THIN SPACER  
Usar un espaciador delgado

USE BRACKETS SHOWN  
Usar los braquetes que se muestran

CUT LOWER BRACKETS  
ALONG CUT LINES  
Cortar los braquetes inferiores a lo largo de las líneas de corte

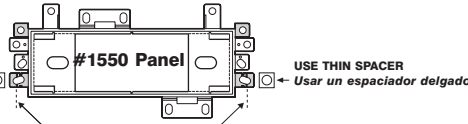

Read pages 2-6  
for kit assembly.

## 1989-95 Plymouth Acclaim

### Radio Removal:

1. Carefully release the spring clips securing the radio/dash trim: three clips along the top and two at the bottom. Disconnect the panel light and remove the trim piece.
2. Extract the two bolts securing the radio: one at the top right, and one at the bottom left of the radio.
3. Pull the radio out of the dash cavity, disconnect the antenna and all electrical connections, and remove the radio.

**NOTE: INSTALLATION OF A DIN UNIT MAY REQUIRE DASH MODIFICATIONS.**  
**NOTA: La instalación de una unidad DIN puede requerir modificar el tablero del vehículo.**

USE THESE SUPPORT TABS AS REQUIRED  
Usar tantas de estas pestañas como sea necesario

USE THIS BRACKET  
Usar este braquete



REMOVE ALIGNMENT PIN - BOTTOM  
Sacar la clavija de alineamiento - Inferior



Read pages 2-6  
for kit assembly.

## 1984-95 Jeep Wrangler

### Radio Removal:

1. Remove three screws from the lower edge of the dash trim.
2. Extract three screws from the upper edge of the dash trim.
3. Remove the dash trim.
4. If the vehicle is not equipped with a factory radio, remove two screws securing the pocket and remove the pocket. If the vehicle is equipped with a factory radio, remove two screws from the radio mounting bracket.
5. Pull the radio out of the cavity, disconnect all electrical connections, then remove the radio.



Read pages 2-6  
for kit assembly.

USE THESE BRACKETS  
Usar estos braquetes

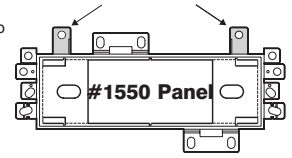

## 1983-87 Lincoln Continental

### Radio Removal:

1. Remove two screws from below the radio.
2. Open the ashtray and remove the two outside screws. Carefully pull the radio trim panel off.
3. Remove four screws securing the radio bracket to the dash. Carefully pull the radio out.
4. Disconnect the power, antenna, speakers, and all electrical leads. Remove the radio.

USE THESE SUPPORT TABS AS REQUIRED  
Usar tantas de estas pestañas como sea necesario

USE THIS BRACKET  
Usar este braquete



Read pages 2-6  
for kit assembly.

## 1984-89 Lincoln Continental Mark VII LSC

### Radio Removal:

1. Carefully pull on the edges of the aluminum radio trim panel to release the clips, and remove the trim panel.
2. Remove four screws which secure the radio to the dash, and slide the radio out of the dash.
3. Disconnect the power, antenna, and all speaker and electrical connections. Remove the radio.

USE THESE SUPPORT TABS AS REQUIRED  
Usar tantas de estas pestañas como sea necesario

USE THIS BRACKET  
Usar este braquete



Read pages 2-6  
for kit assembly.

**NOTE: INSTALLATION OF A DIN UNIT MAY REQUIRE DASH MODIFICATIONS.**  
**NOTA: La instalación de una unidad DIN puede requerir modificar el tablero del vehículo.**

**SECURE THE BRACKETS TO THE BOSSES LOCATED ON THE BACK SIDE OF THE KIT WITH THE SUPPLIED HARDWARE. SEE PAGE 3.**  
**Asegurar los braquetes en sus ranuras en la parte posterior del juego usando los tornillos autoenroscantes provistos. Ver la página 3.**

## 1980-88 Ford Thunderbird 1983-88 Mercury Cougar



### Radio Removal:

1. Remove two screws from the pocket between the ashtray and radio trim. Remove the pocket.
2. Remove four screws from the radio trim: two from the top, and two from the bottom edge.
3. Remove the radio trim.
4. Remove four screws retaining the radio and remove the radio. Disconnect the power, antenna and all speaker and electrical connections.

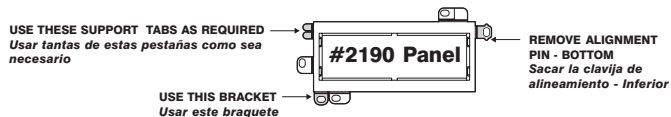

## 1984-96 Jeep Cherokee 1985-92 Jeep Comanche 1984-91 Jeep Grand Wagoneer



### Radio Removal:

1. Remove two screws from the instrument panel, one from above the cigarette lighter, and one from above the headlight switch. Unsnap and remove the lower steering column trim piece and remove the trim panel.
2. If equipped with a factory radio, remove the two screws securing the radio brackets to the dashboard.
3. Pull the radio out of the cavity, disconnect all electrical connections, then remove the radio.



## 1980-82 Mercury Cougar XR-7



### Radio Removal:

1. Remove three screws inside the ashtray from the radio trim panel.
2. Remove the radio knobs, pull the trim panel out from the bottom and remove it.
3. Remove four screws securing the radio mounting bracket to the dash, and pull the assembly out.
4. Disconnect the power, antenna, and all speaker and electrical connections.

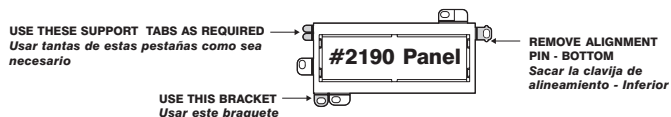

## 1999-04 Jeep Grand Cherokee



### Radio Removal:

1. Carefully pop up out radio/vent trim bezel and remove.
2. Extract four screws holding radio in, unplug and remove radio.

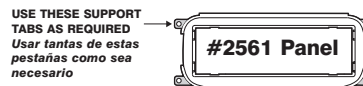

## 1997-01 Jeep Cherokee



### Radio Removal:

1. Pop out dash bezel bottom first and remove.
2. Extract two screws holding radio, unplug and remove.

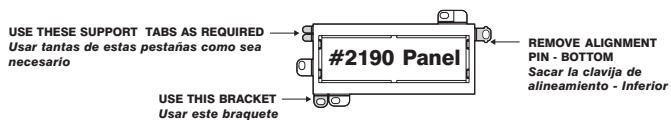

## 1996-98 Jeep Grand Cherokee



### Radio Removal:

1. Extract five screws from along top of dash instrument bezel.
2. Carefully pop out wood grain trim panel around a/c heater control.
3. Carefully pop out wood grain trim panel around headlight switch.
4. Extract four screws from along bottom of dash instrument bezel, lift up and away to remove.
5. Extract two 3/8" hex head bolts holding radio, unplug connectors and remove.

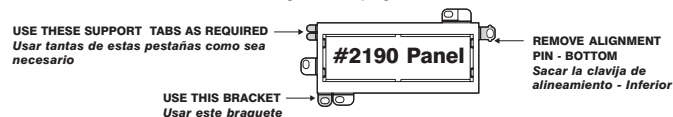

## 1993-95 Jeep Grand Cherokee 1992 Jeep Grand Wagoneer



Read pages 2-6  
for kit assembly.

### Radio Removal:

1. Extract two screws from above the radio securing the radio trim bezel.
2. Extract two screws from above the diagnostics display panel securing the radio trim bezel.
3. Carefully remove the ashtray and extract two screws located in the ashtray cavity securing the radio trim bezel.
4. Pull the radio trim bezel away from the dash, unplug all connectors and remove the bezel.
5. Extract two nuts securing the radio to the dash, and pull the radio from the cavity; unplug all connectors and remove the radio.

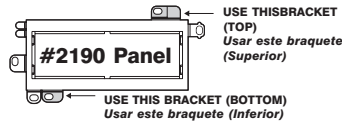

## 2002-06 Jeep Liberty



Read pages 2-6  
for kit assembly.

### Radio Removal:

1. Remove ashtray and extract one Philips screw from behind.
2. Carefully pry out radio bezel using fingers, disconnect, and remove.
3. Extract four Philips head screws securing radio, disconnect, and remove.

USE THESE SUPPORT  
TABS AS REQUIRED  
Usar tantas de estas  
pestañas como sea  
necesario

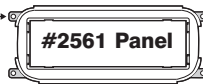

## 2003-06 Jeep Wrangler



Read pages 2-6  
for kit assembly.

### Radio Removal:

1. Apply emergency brake. Turn ignition on, but **DO NOT START VEHICLE**. Shift into 1st gear.
2. Lift off defroster vent bezel from either side to unsnap four clips. Remove two Philips head screws located in front of the defroster air vents that hold the bezel that surrounds the radio and climate control. Pull on the bezel from the lower corners to release, pull from the left and right corners of the lower radio opening with your hands or use a pry tool to remove bezel and set aside.
3. Extract four Philips head screws securing radio, disconnect, and remove.

USE THESE SUPPORT  
TABS AS REQUIRED  
Usar tantas de estas  
pestañas como sea  
necesario

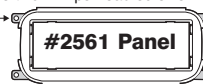

## 1997-02 Jeep Wrangler



Read pages 2-6  
for kit assembly.

### Radio Removal:

1. Extract two screws from dash bezel.
2. Pry on bezel to release spring clips and remove.
3. Extract two screws holding radio, unplug and remove.

USE THESE SUPPORT  
TABS AS REQUIRED  
Usar tantas de estas  
pestañas como sea  
necesario

USE THIS BRACKET  
Usar este braquete



REMOVE  
ALIGNMENT  
PIN - BOTTOM  
Sacar la clavija  
de alineamiento  
- Inferior