

SCOSCHE®

CJ1278

IN-DASH INSTALLATION KIT FOR SELECT 1974-UP CHRYSLER AND JEEP VEHICLES

INTRODUCTION

The Scosche in-Dash Installation Kit for 1974-UP Chrysler and Jeep Vehicles provides the parts you need to mount your car stereo/cassette player into your vehicle's dash. Refer to the individual instructions in this manual to remove your vehicle's factory installed radio.

PRELIMINARY PARTS LIST

Your kit includes:

- 1 Mounting Panel
- 2 Spacers
- 2 Snap Shaft Brackets
- 2 ISO Mount Brackets
- 1 ISO Trim Ring
- 1 Snap-In Pocket

CAUTION:

Disconnect your vehicle's negative battery terminal before the installation to help prevent electrical damage. We recommend the use of a volt/ohm meter over a test light to check wiring. A test light or grounded wire probe can cause damage to the vehicle's computer and/or diagnostic systems. Avoid all factory airbag wiring. Airbags can accidentally deploy causing serious injury or death.

NOTES:

- See your vehicle's instructions for any special tools your installation might require.
- Read all instructions accompanying your car stereo/cassette player for proper wiring and mounting instructions.

ASSEMBLING THE KIT

The instructions for each vehicle show which mounting panel and brackets to use.

Use the shaded mounting tabs and indicated brackets. Carefully break or cut off the unused brackets. Then assemble the radio and the mounting panel as shown below, and secure the kit to your dash using the supplied screws. Reassemble your dash, and attach the radio's front panel and controls. The following example shows a typical installation.

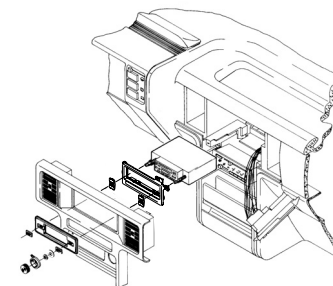

ASSEMBLING THE POCKET

1. Locate and align bottom guides and top snaps of the pocket to kit panel.
2. Slide pocket on bottom guides while the top snaps are aligned.
3. When aligned properly, the top pocket snaps will lock to kit panel.

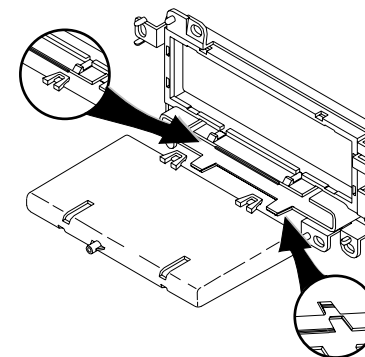

1996-98 Jeep Grand Cherokee

Radio Removal:

1. Extract (5) screws from along top of dash instrument bezel.
2. Carefully pop out wood grain trim panel around a/c heater control.
3. Carefully pop out wood grain trim panel around headlight switch.
4. Extract (4) screws from along bottom of dash instrument bezel, lift up and away to remove.
5. Extract (2) 3/8" hex heard bolts holding radio, unplug connectors and remove.

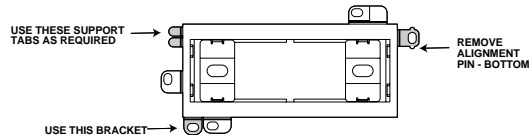

1978-02 Dodge Ram Van

1978-83 Plymouth Van

Radio Removal:

1. Remove two screws securing the dash panel inside the glove box.
2. Remove four screws from the bottom edge of the dash panel and one on the left side of the panel.
3. Carefully pull the panel from the dash and remove the panel.
4. Remove two screws securing the radio to the dash. Pull the radio out.
5. Disconnect power, antenna, and all speaker and electrical connections.

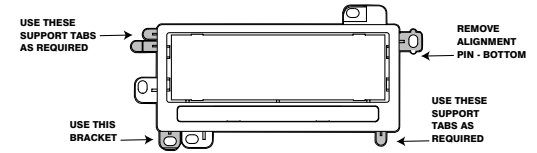

1993-95 Jeep Grand Cherokee

Radio Removal:

1. Extract two screws from above the radio securing the radio trim bezel.
2. Extract two screws from above the diagnostics display panel securing the radio trim bezel.
3. Carefully remove the ashtray and extract two screws located in the ashtray cavity securing the radio trim bezel.
4. Pull the radio trim bezel away from the dash, unplug all connectors and remove the bezel.
5. Extract two nuts securing the radio to the dash, and pull the radio from the cavity; unplug all connectors and remove the radio.

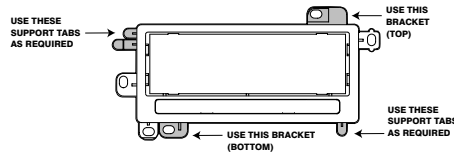

1987-94 Dodge Shadow

1987-94 Plymouth Sundance

Radio Removal:

1. Remove the ashtray
2. Carefully pull outward on the edges of the trim panel to release the snaps, and remove the panel.
3. Remove one retaining screw from above the right upper corner of the radio.
4. Pull the dash trim towards the passenger side to gain access to the upper right radio bolt; remove the top right bolt and the lower left bolt.
5. Pull out the radio. Disconnect the power, antenna, speaker leads, and all other electrical connections. Remove the radio.

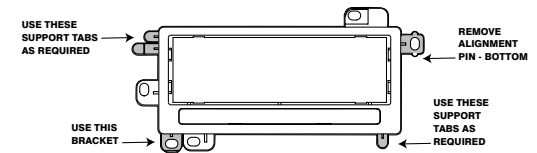

1997-02 Jeep Wrangler

Radio Removal:

1. Extract (2) screws from dash bezel.
2. Pry on bezel to release spring clips and remove.
3. Extract (2) screws holding radio, unplug and remove.

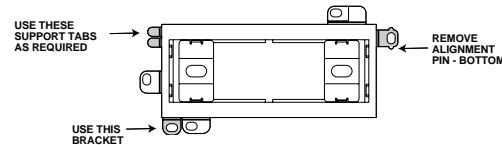

1989-95 Plymouth Acclaim

Radio Removal:

1. Carefully release the spring clips securing the radio/dash trim: three clips along the top and two at the bottom. Disconnect the panel light and remove the trim piece.
2. Extract the two bolts securing the radio: one at the top right, and one at the bottom left of the radio.
3. Pull the radio out of the dash cavity, disconnect the antenna and all electrical connections, and remove the radio.

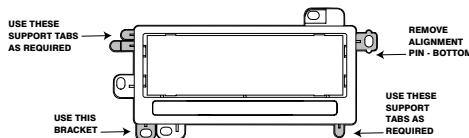

1989-95 Dodge Spirit

Radio Removal:

1. Carefully release the spring type fasteners from the radio/console trim panel - three from along the top and two from the bottom of the panel.
2. Remove two screws from along the top of the side console trim piece, and spread the side piece out slightly for access to the radio bolt.
3. After spreading the side piece, extract the top right radio mounting bolt, then remove the bottom left bolt.
4. Spread the side piece once again to provide clearance for pulling the radio out of the cavity; pull the radio out, disconnect the connectors, and remove the radio.

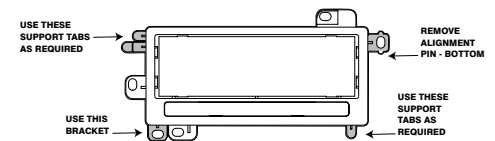

ASSEMBLING THE KIT (Cont'd)

1995-99 Dodge Neon 1995-99 Plymouth Neon

Radio Removal:

1. Remove the ashtray from the dash.
2. Carefully pry outward on the radio trim bezel to release spring clips then remove.
3. Extract the two 3/8" screws securing the radio to the dash, pull the radio from the dash cavity, unplug all connectors, disconnect the ground strap and remove the radio.

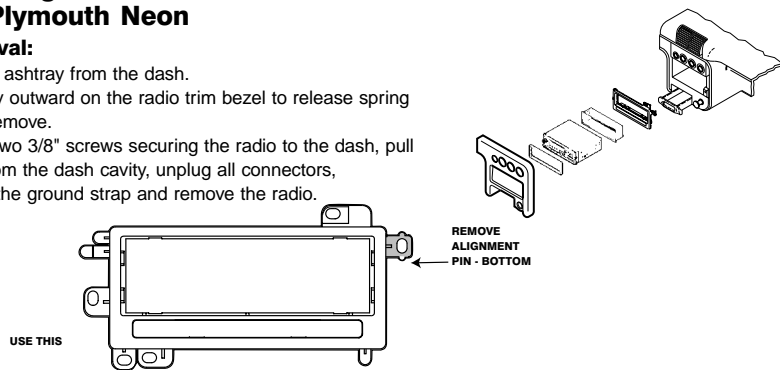

1998-01 Dodge Ram

Radio Radio:

1. Extract (1) Screw from lighter socket area.
2. Carefully pryout on the radio dash bezel to release the fastening clips, disconnect all connectors and remove the bezel.
3. Extract the (2) screws securing the radio to the dash, pull the radio from the dash cavity, unplug all connectors, disconnect the ground strap and remove the radio.

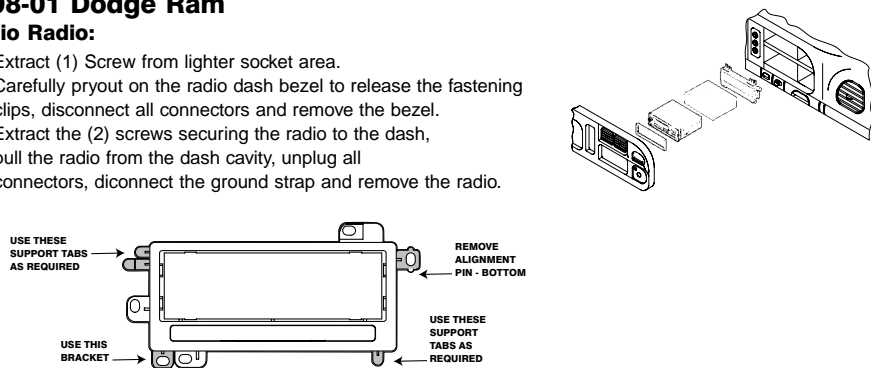

1994-97 Dodge Ram Pickup

Radio Removal:

1. Remove the ashtray from the dash, extract the two screws securing the ashtray bracket to the dash and remove the bracket.
2. Open up the cup holder and extract the two screws securing it to the dash.
3. Carefully pry out on the perimeter radio dash bezel using a panel removal tool to release the fastening clips, disconnect all connectors and remove the bezel.
4. Extract the two screws securing the radio to the dash, pull the radio from the dash cavity, unplug all connectors, disconnect the ground strap and remove the radio.

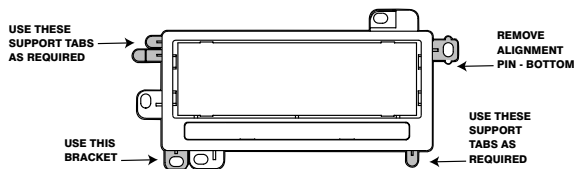

SHAFT MOUNT (DIN-C) RADIOS

Using the radio's knobs/hardware, secure the radio to the mounting panel and to the shaft radio faceplate as shown.

CAUTION:

REAR SUPPORTING THE RADIO ADDS TO THE INSTALLATION'S STRUCTURAL INTEGRITY.

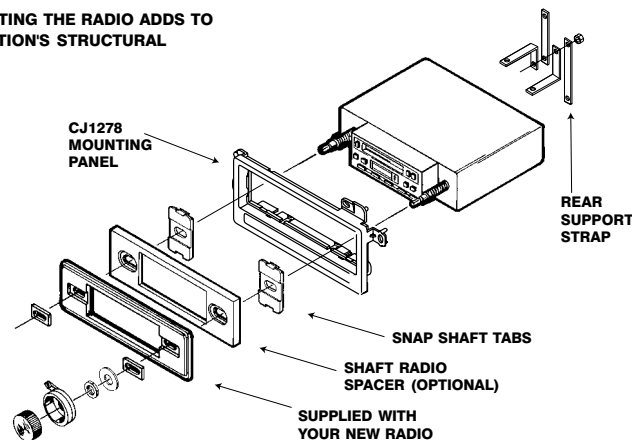

DIN-ISO MOUNT: (DIN-E Radio with Side Mounting Holes)

1. Snap the DIN iso side mounting brackets to the back of the mounting panel (1 left and 1 right). Use supplied hardware to bolt them to the back of the kit panel.
2. Snap the DIN-ISO Trim Ring into the radio opening.
3. Load the Radio from the REAR of the mounting panel until the nosepiece of the radio comes through the front of the kit.
4. Use the 5MM screws to secure the radio from the sides.

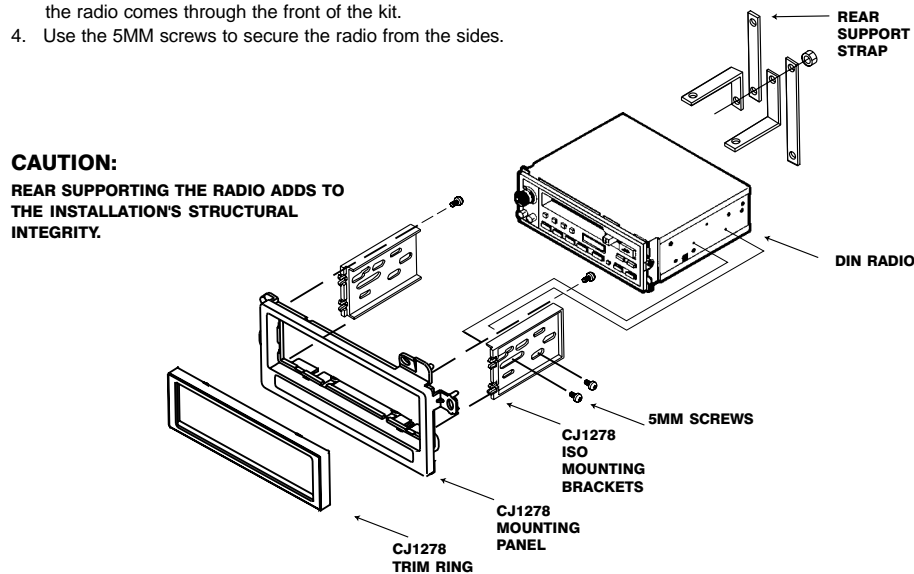

CAUTION:

REAR SUPPORTING THE RADIO ADDS TO THE INSTALLATION'S STRUCTURAL INTEGRITY.

ASSEMBLING THE KIT (Cont'd)

IN-DASH DIN PULLOUT, DETACHABLE FACEPLATE, (DIN-E) RADIOS

The kit panel comes DIN ready. Follow the instructions supplied with the radio, secure the mounting kit. Install the assembly in the dash and use the rear support strap supplied with the radio to support the rear of the radio.

CAUTION:

REAR SUPPORTING THE RADIO ADDS TO THE INSTALLATION'S STRUCTURAL INTEGRITY.

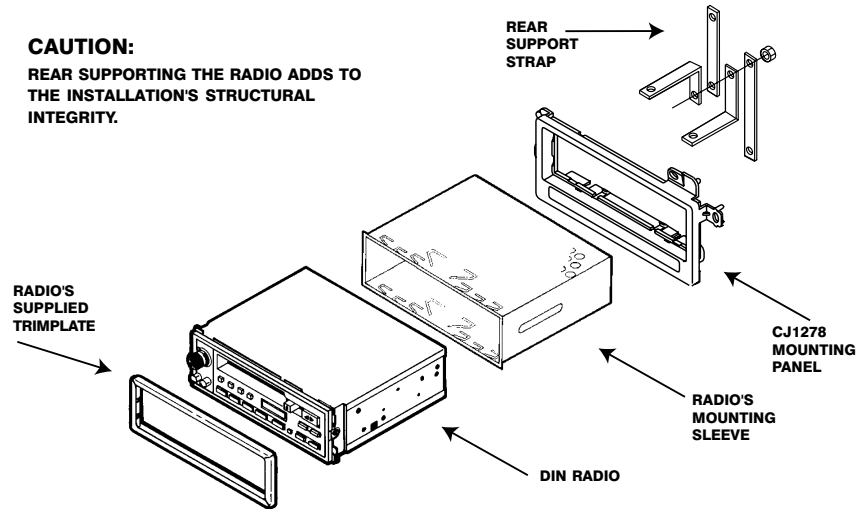

1998-00 Dodge Durango 1997-00 Dodge Dakota

Radio Removal:

1. Remove eight screws from the dash trim panel.
2. Remove two screws from the underside of the steering column trim, and remove the trim.
3. Remove two screws from the radio mounting bracket, disconnect power antenna, speaker leads, and all other electrical connections, and remove the radio.

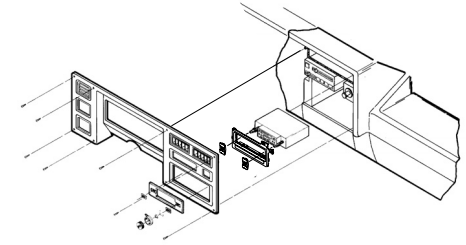

USE THESE SUPPORT TABS AS REQUIRED

USE THIS BRACKET

REMOVE ALIGNMENT PIN - BOTTOM

USE THESE SUPPORT TABS AS REQUIRED

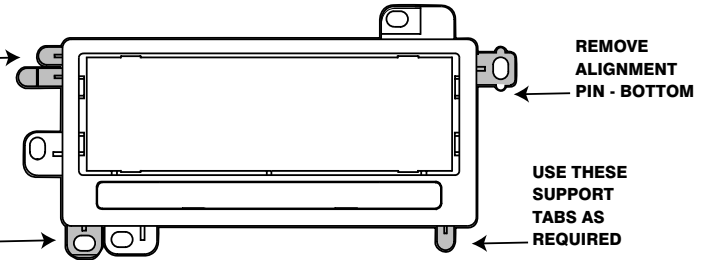

1995-00 Chrysler Cirrus 1995-00 Chrysler Sebring JX Convertible 1995-00 Dodge Stratus

Radio Removal:

1. Carefully pry out on the radio/heater control trim bezel, unsnap to remove.
2. Extract two 3/8" bolts holding radio in, unplug and remove radio.

NOTE: The rear of the aftermarket stereo should be supported.

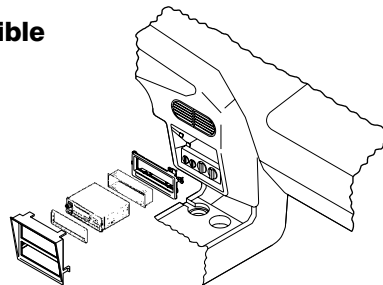

USE THESE SUPPORT TABS AS REQUIRED

USE THIS BRACKET

REMOVE ALIGNMENT PIN - TOP

USE THESE SUPPORT TABS AS REQUIRED

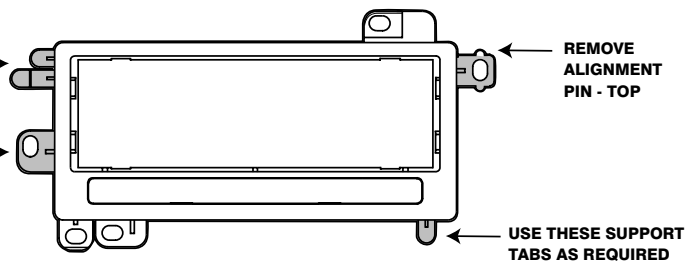

1990-93 Dodge Daytona

Radio Removal:

1. Pull firmly outward on the console/radio trim panel - secured by five metal spring clips, two at the top, two on the right side and one on the left side.
2. Extract the top two screws from each side of the lower console - this allows you to slightly spread the console, providing clearance to remove the radio.
3. Remove the remaining two screws securing the radio, disconnect the connectors and remove the radio.

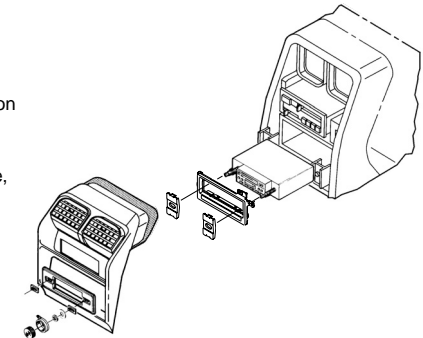

USE THESE SUPPORT TABS AS REQUIRED

USE THIS BRACKET

REMOVE ALIGNMENT PIN - BOTTOM

USE THESE SUPPORT TABS AS REQUIRED

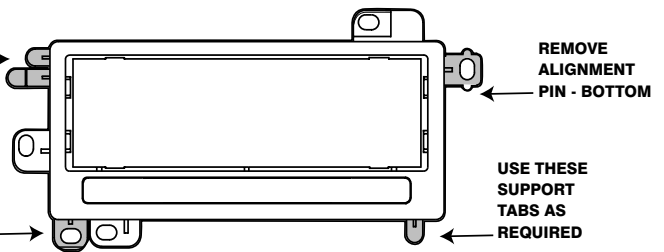

1991-93 Chrysler Town & Country
1991-93 Dodge Caravan
1991-93 Plymouth Voyager

Radio Removal:

1. Remove the cigarette lighter.
2. Using a panel removal tool, carefully pry outward to release the clips securing the dash bezel and remove the bezel.
3. Extract the two screws securing the rear hatch switch to the dash bezel.
4. Extract the two 3/8" bolts securing the radio to the dash.
5. Pull the radio out of the dash, and unplug all the connectors. Disconnect the ground strap and remove the radio.

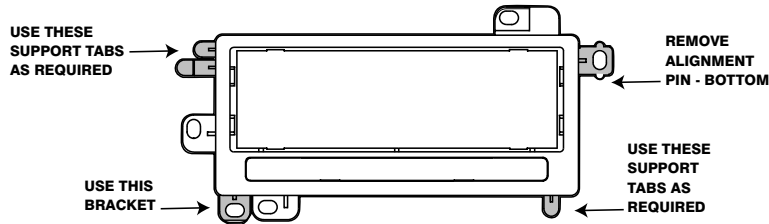
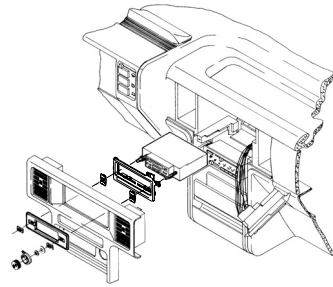

1993-97 Chrysler Concorde
1993-97 Dodge Intrepid
1993-97 Eagle Vision

Radio Removal:

1. Pull the radio trim bezel out to release the snap clips, and remove the bezel.
2. Extract the two bolts securing the radio, pull the radio from the cavity, unplug all connectors and remove the radio.

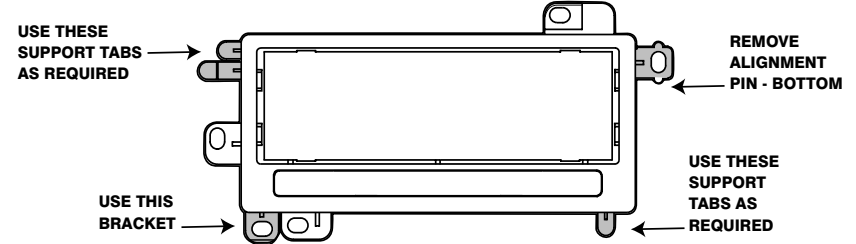
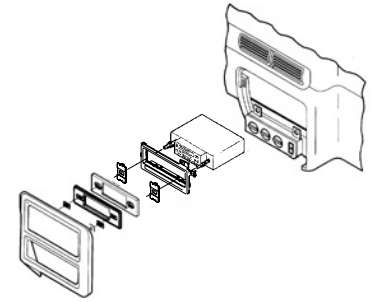

1990 Chrysler Town & Country
1984-90 Dodge Caravan
1984-90 Plymouth Voyager

Radio Removal:

1. Reach behind ashtray and unsnap the carrier housing to remove the ashtray.
2. Remove three screws along the top edge of the radio trim panel.
3. Remove two screws below the radio trim panel. Remove the trim panel.
4. Remove two screws securing the radio to dash then pull the radio out.
5. Disconnect the power, antenna, and all speaker and electrical connections. Remove the radio.

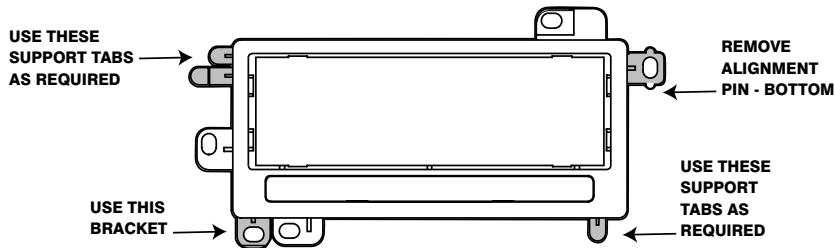
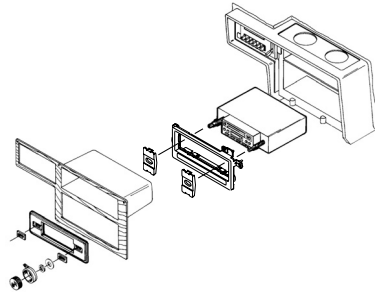

1980-83 Chrysler Cordoba
1980-83 Dodge Mirada

Radio Removal:

1. Remove four screws securing the radio dash panel: two above the radio and two above the heater controls.
2. Remove the radio dash panel. Remove two screws securing the radio to the dash. Pull the radio out.
3. Disconnect power, antenna, and all speaker and electrical connections.

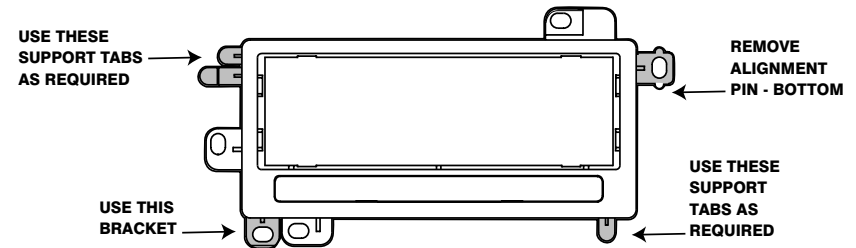
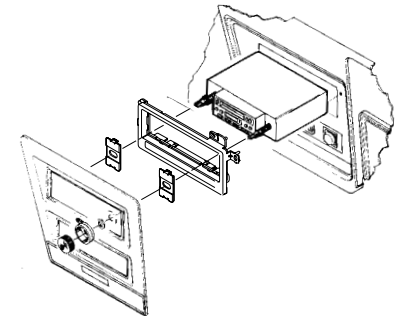

1975-79 Chrysler Cordoba
1975-77 Plymouth Fury

Radio Removal:

1. Remove four securing screws from the bottom edge of the radio dash panel.
2. Remove two securing screws from the top edge of the panel above the radio.
3. Unscrew the retainer ring securing the remote mirror control and remove the panel.
4. Remove two screws securing radio to the dash. Pull the radio out.
5. Disconnect power, antenna and all speaker and electrical connections.

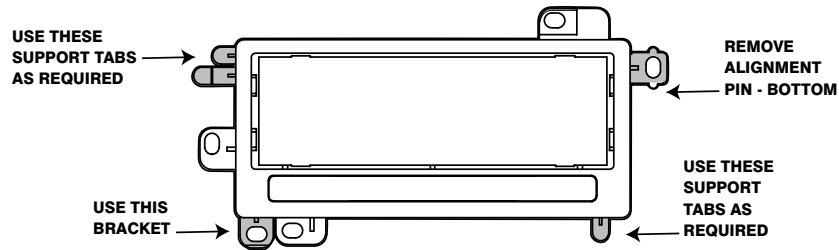
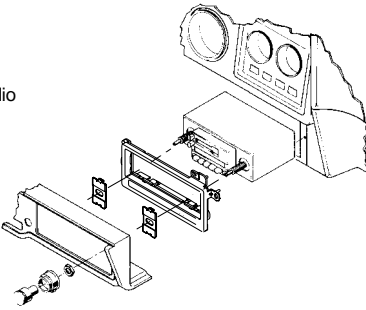

1996-00 Chrysler Town & Country
1996-00 Dodge Caravan
1996-00 Plymouth Voyager

Radio Removal:

1. Extract two screws in the trim bezel from just above the radio.
2. Pull the radio trim bezel away from the dash, unplug the ac/heating control.
3. Extract the two screws securing the radio to the dash, pull the radio from the cavity, disconnect the ground strap, unplug all connectors and remove the radio.

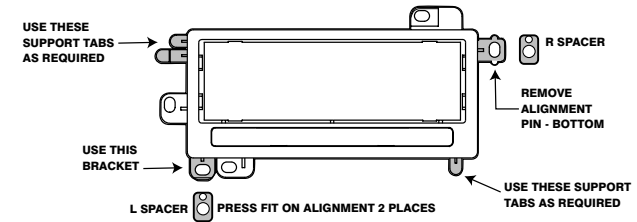
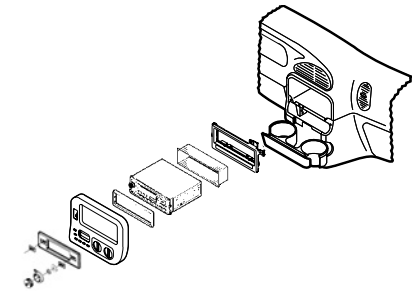

1990-93 Chrysler Fifth Avenue/Imperial
1988-93 Chrysler New Yorker
1988-93 Dodge Dynasty

Radio Removal:

1. Remove five screws from along the top side of the radio/instrument panel dash trim.
2. Lower the steering column, place the gear selector in drive, then remove the trim panel.
3. Remove two bolts securing the radio, and pull the radio out, disconnect wire harnesses, ground strap and antenna lead, then remove the radio.

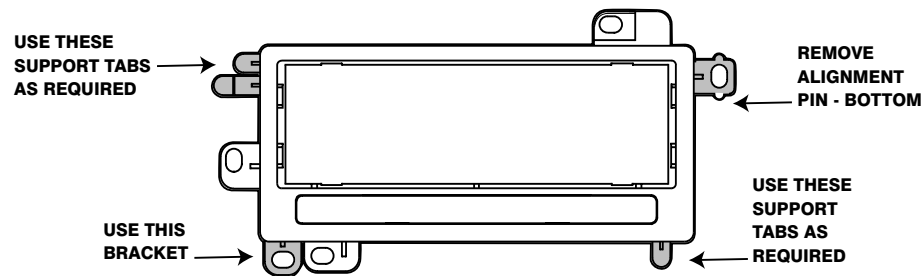
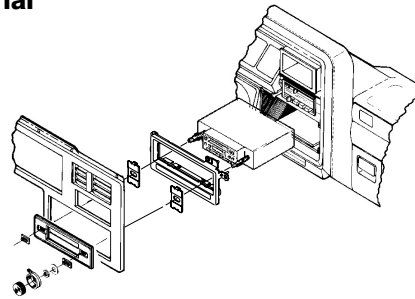

1994-95 Chrysler Town & Country
1994-95 Dodge Caravan
1994-95 Plymouth Voyager

Radio Removal:

1. Using a panel removal tool carefully pry up on the dash panel at the base of the windshield (speaker grille panel) to release the fastening clips securing it to the dash and pull out on the panel to remove.
2. Pry up the piece of trim that looks like a vent in front of the instrument light cluster on top of the dash using a panel removal tool to release and remove the trim.
3. Carefully pry out on the trim panel surrounding the heater controls using a panel removal tool to release the fastening clips securing the trim to the dash and remove the trim.
4. Extract the three screws securing the bottom of the radio trim bezel to the dash.
5. Extract the three screws securing the front of the instrument light cluster to the top of the dash.
6. Extract the screw securing the back of the instrument light cluster to the dash, pry up on the light cluster with a panel removal tool, unplug all connectors and remove.
7. Extract the three screws securing the top of the radio trim bezel to the dash on the drivers side of the dash.
8. Pull the radio trim bezel away from the dash, unplug all connectors, shift the gear select lever into Low, tilt the steering wheel down and remove the bezel.
9. Extract the two screws securing the radio to the dash, pull the radio from the cavity, disconnect the ground strap unplug all connectors and remove the radio.

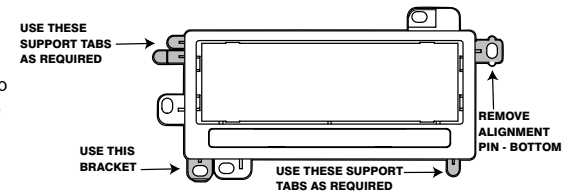
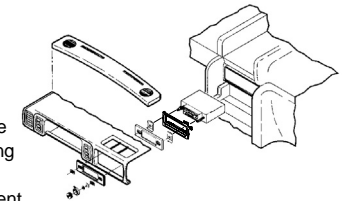

1975-78 Chrysler Newport, New Yorker
1975-77 Dodge Royal Monaco
1975-79 Plymouth Gran Fury

Radio Removal:

1. Remove three screws from the bottom edge of the dash panel.
2. Remove the ashtray and remove one screw retaining the dash panel.
3. Disconnect the cigarette lighter and wiper wires.
4. Pull the dash panel out from the top. Place the gear selector in low gear and remove the dash panel.
5. Release the radio rear support. Remove two screws securing the radio to the dash. Pull the radio out.
6. Disconnect the power, antenna, and all speaker and electrical connections.

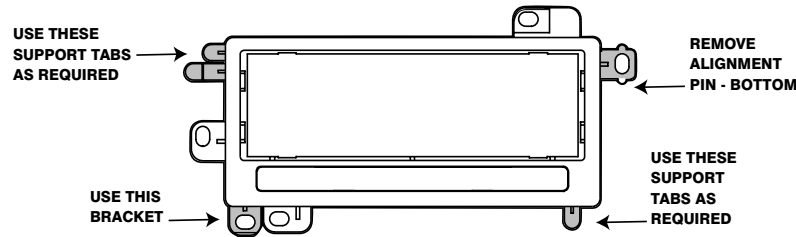
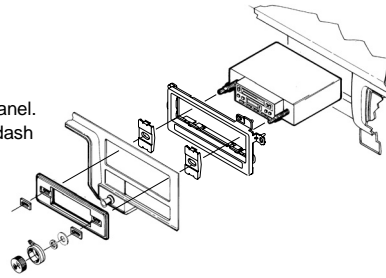

1979-89 Chrysler Fifth Avenue
1977-81 Chrysler Le Baron
1977-89 Dodge Diplomat
1984-89 Plymouth Gran Fury

Radio Removal:

1. Remove four screws from the top edge of the dash panel and four screws from the bottom edge. Remove the panel.
2. Remove two screws securing the radio to the dash and pull out.
3. Disconnect power, antenna, and all speaker, and electrical connections.

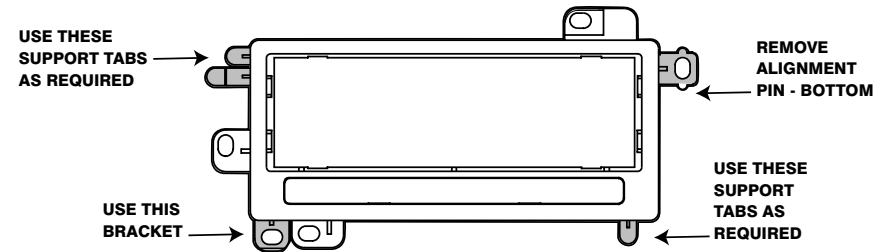
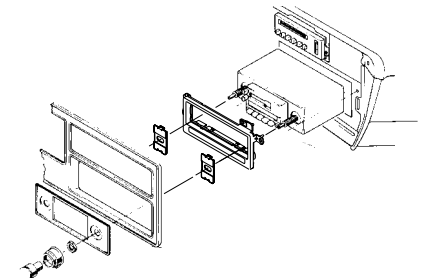

1995-00 Chrysler Sebring
1995-00 Dodge Avenger

Radio Removal:

1. Carefully pry out on radio/AC control trim bezel to release the snap clips. Remove the bezel.
2. Extract the two screws holding radio in, unplug connector, unbolt ground wire from rear of radio and remove radio.

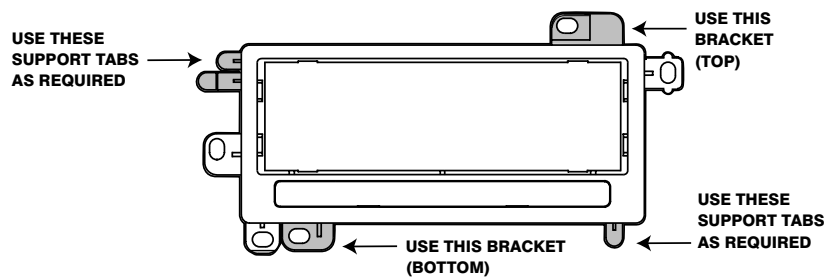
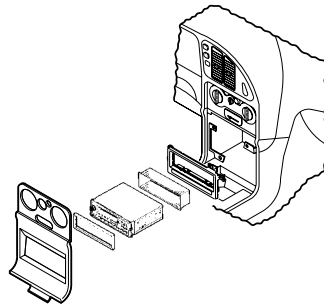

1984-87 Chrysler New Yorker

Radio Removal:

1. Remove nine securing screws from the top and bottom of the radio trim panel. Remove the panel by pulling it down and out.
2. Unhook the wiring harness.
3. Remove the two Chrysler anti-theft bolts retaining the radio (use Snap-On bit TTW 12 for 1/4" drive) and remove the radio. Disconnect power, ground cable, antenna and speaker wires.

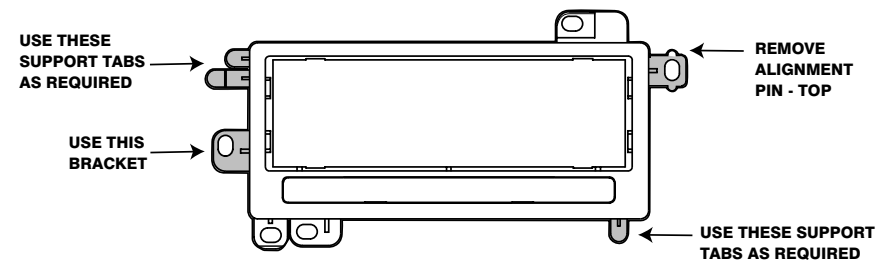
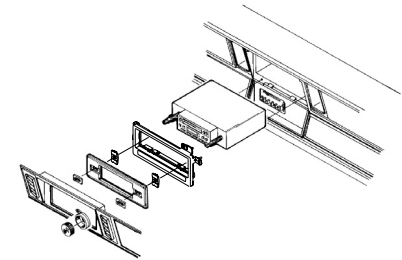

1981-83 Chrysler Imperial
1979-81 Chrysler Newport
1979-83 Chrysler New Yorker
1979-81 Dodge St. Regis

Radio Removal:

1. Remove four screws securing the radio dash panel: two above the radio and two above the heater controls.
2. Remove radio dash panel.
3. Remove two screws securing the radio to the dash. Pull the radio out.
4. Disconnect power, antenna, and all speaker and electrical connections.

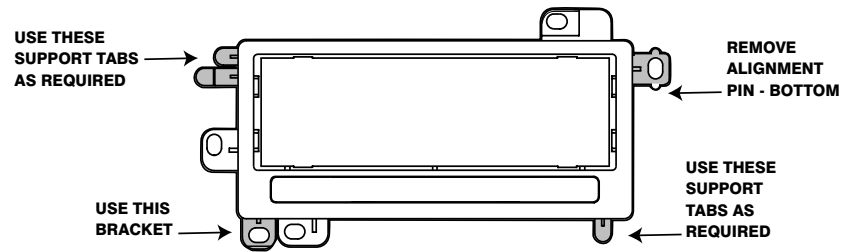
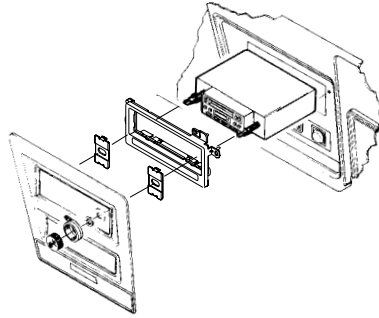

1987-93 Chrysler Le Baron "Coupe"

Radio Removal:

1. Remove two screws, one from each lower corner of the radio/console trim panel.
2. Gently snap off the trim panel.
3. Remove two screws securing the right side panel of the console, one at top, one at bottom; remove the side panel.
4. Remove two screws from the radio mounting bracket. Disconnect the wire harness, antenna lead, and ground strap. Remove the radio.

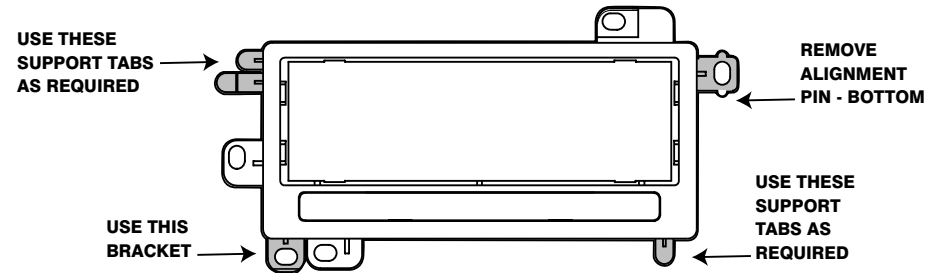
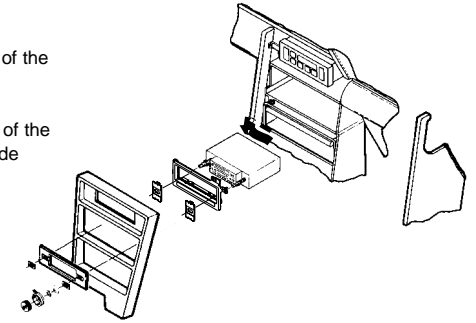

1984-86 Chrysler Laser

Radio Removal:

1. Remove one screw from each side of the ashtray.
2. Pull off the trim panel.
3. Remove two screws securing the radio to the dash. Pull the radio out.
4. Disconnect the power, antenna, and all speaker and electrical connections.

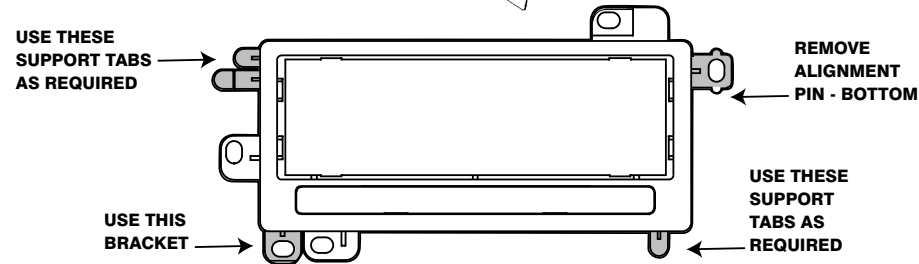
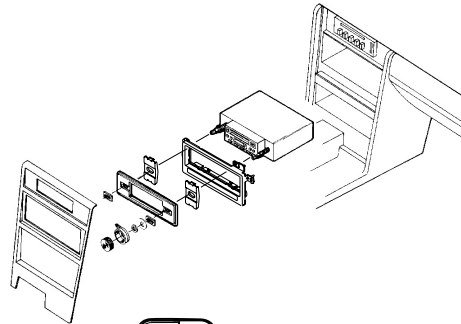

1994-97 Chrysler LHS
1994-96 Chrysler New Yorker

Radio Removal:

1. Remove the ashtray from the dash.
2. Carefully pry out on the perimeter radio dash bezel using a panel removal tool to release the fastening clips and remove the radio dash bezel.
3. Extract the two screws securing the radio to the dash, pull the radio from the dash cavity, unplug all connectors and remove the radio.

