



SARIS

Cargo Accessory

4425



LONG FOR THE RIDE

Just as no garage is complete without a bicycle, at Saris, we believe no car is complete without a bike rack.

Since setting off on this journey nearly 30 years ago, Saris racks have freed millions of bike-lovers to explore new territory and terrain, take part in group rides, bike pool to races, and commute to and from work.

And we continue to do so in style.

As the all-time #1 best-selling bike rack, Saris Bones® continues to set the standard for excellence in design. Today all Saris bicycle racks are intuitive to load and secure, and guaranteed for life.

Built by cyclists for cyclists in Madison, Wisconsin, we strive to create the world's best bike racks.

Because cycling is what we live for.

MADE IN USA

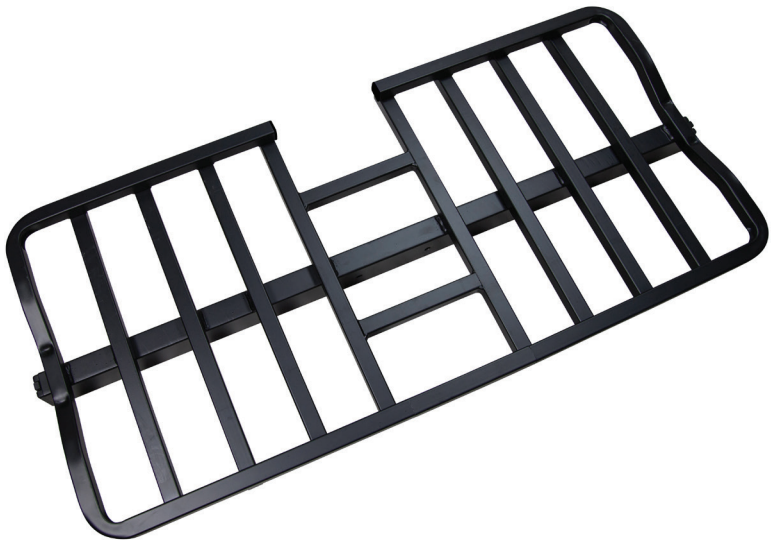

Specifications: 4425 Cargo Accessory

Compatible with Saris Rack models:
4026, 4026F, 4414, 4414B

Cargo: Max = 120 lbs/54kg
Be sure cargo weight is centered on the platform.
Cargo straps not included. User is responsible for
properly securing cargo to platform.

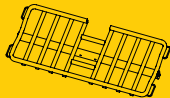

Refer to your Rack Owner's Manual to determine maximum
acceptable bike weight.



Tools Needed:

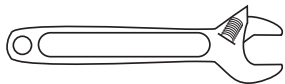

Adjustable or 19mm and 17mm

Items Included:



x 2

M10 x 60



x 2

M10 x 75

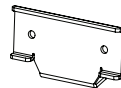

x 1

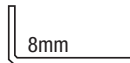

x 1

8mm



x 1

6mm

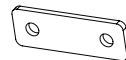

x 1



x 4

M10

*Refer to your base model user manual for bike installation and general rack use instructions.

1

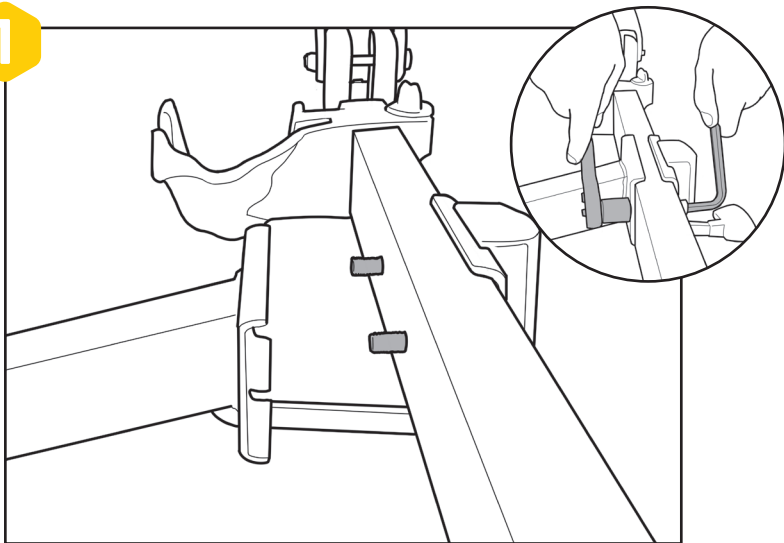

EN Remove horizontal bar of the first two bike positions closest to vehicle by removing the 17mm nuts and 8mm bolts.

2

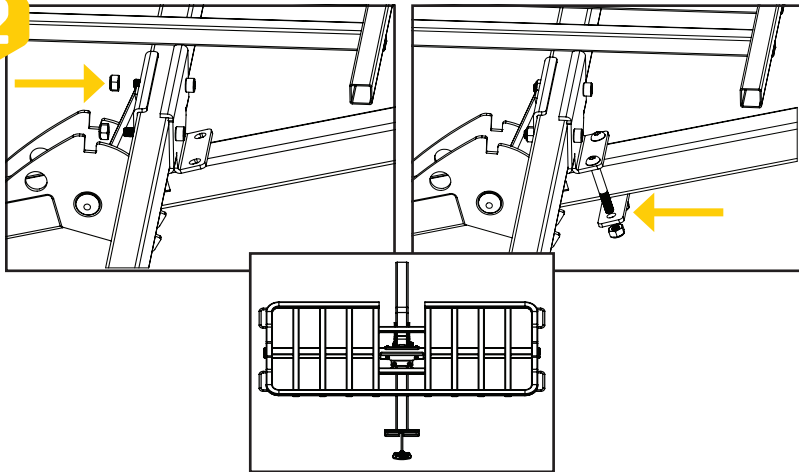

EN Line up bracket with cargo bar and receiver, ensuring the cutout in the cargo tray is towards the vehicle. Secure with 60mm bolts and nuts, using 17mm (9/16") wrench and 8mm hex key. Clamp bracket and backing plate to the receiver with 75mm bolts and nuts, using 17mm (9/16") wrench and 6mm hex key. Recommended torque spec 15ft-lb.

EN Technical Specifications

Accessory Tray weight: 31lb/14kg

Permitted cargo capacity: 120lb/ 54.4kg

CAUTIONS:

- All requirements for compatibility/fit as stated in the current Saris vehicle/carrier compatibility guide must be followed.
- Read and follow instructions carefully. Save owner's manual for future reference or parts information. Ensure that any other users of the bicycle carrier are familiar with their content.
- Drive slowly over speed bumps, 5 to 10 mph max speed.
- It's the end users responsibility to ensure that use of this product meets all local and state laws.
- When cleaning vehicle and rack, use only water soluble cleaners. Do not take rack through car wash.
- Make sure bike tires are not directly behind exhaust pipe.
- Rack must be installed directly into vehicle hitch receiver. Do not modify the hitch receiver or use hitch extenders.
- Do not mount to any type of trailer or RV including Class B vehicles.
- Prior to usage on the road, remove all loose parts from bicycle, including (but not limited to) child seat, basket, lock, light, pump, etc.
- This carrier is not recommended for off-road use or for use at speed exceeding 70 mph (113 km/h).
- The handling characteristics of a vehicle will change when a rear bicycle carrier is fitted and especially when it is loaded (in particular crosswind sensitivity, handling on bends and braking). Driving techniques should be altered to allow for these changes, reduce speed, especially on bends and allow for longer braking distances.
- The vehicle's total length increases when the bike carrier is attached. The bikes themselves may increase the vehicle's total width and height. Take care when reversing and/or entering garages or ferries, etc.
- Remove carrier from vehicle when not in use.
- This carrier is constructed to carry standard-bike-frames. It is not intended for use with tandem or recumbent bicycles.

- Tighten straps regularly during the journey.
- Vehicle should be in good condition in the area at which the hitch is located.
- Do not exceed maximum load capacity of carrier (120 lbs for tray or 35 lbs max per bike) Secure properly and adjust for even load distribution, loading the heaviest/biggest bike first and closest to the vehicle.
- Saris absolves itself of responsibility for any personal injuries or consequential damage to property or wealth caused by incorrect fitting or use.
- Be sure cargo weight is centered on the platform.
- Cargo straps not included.
- User is responsible for properly securing cargo to platform.

Warning and Disclaimer:

This carrier has been designed to carry bicycles on specific vehicles. Before installation, user must read and follow current Saris Fit Guide (available through Saris dealer) recommendations and enclosed instructions. Fit recommendations are based on vehicle's standard features; optional features may affect the fit recommendations. User must attach carrier correctly to the vehicle, check its attachment before each use, and inspect carrier parts for wear. Carrier's attachment to the vehicle is critical and beyond the control of the manufacturer. Manufacturer and seller expressly disclaim any and all liability for personal injury, property damage or loss, whether direct, indirect, or incidental, resulting from the incorrect attachment, improper use, inadequate maintenance, or neglect of this carrier.

Kool Rack: 1 year

Parking Racks: 1 year

Note: No damage to mounting surfaces is covered.

Any product or part thereof found to be defective within the term as set forth above will be replaced without charge provided that: (1) its failure resulted from a defect in material or workmanship and not from normal wear and tear expected in the use of the product; (2) the product was not misused, improperly assembled, improperly maintained or damaged by accident; (3) there was no failure to follow instructions or warnings in Owner's Manual; (4) no alterations or modifications were made; and (5) the product or part is delivered, freight prepaid, to Saris Cycling Group or an authorized service center. SCG's only obligation shall be to replace such products or parts that it determines are defective.

EXCLUSIONS

- If consumer does not heed cautions listed in Instruction Manual, damage is not covered under warranty
- Impact/collision damage is not covered under warranty
- Cradles and strap damage due to improper arm placement are not covered under warranty
- Carrying anything other than a bicycle is not covered under warranty
- Rust is wear and tear and is preventable with rack maintenance
- Weather impact (UV, salt air/water)

RECOMMENDED RACK MAINTENANCE

Each use:

- Wipe down trunk rack feet
- Check straps for signs of wear
- Check bike cradles and wheel scoops
- Check for loose bolts

Every 90 days actions

- Clean with water and mild soap
- Lubricate locks if applicable (use wet, oil based lubricant; NO WD-40)
- Grease hitch bolt threads
- Check for scratches in paint