



**SARIS**

Bones EX



# LONG FOR THE RIDE

Just as no garage is complete without a bicycle, at Saris, we believe no car is complete without a bike rack.

Since setting off on this journey nearly 30 years ago, Saris racks have freed millions of bike-lovers to explore new territory and terrain, take part in group rides, bike pool to races, and commute to and from work.

And we continue to do so in style.

As the all-time #1 best-selling bike rack, Saris Bones® continues to set the standard for excellence in design. Today all Saris bicycle racks are intuitive to load and secure, and guaranteed for life.

Built by cyclists for cyclists in Madison, Wisconsin, we strive to create the world's best bike racks.

Because cycling is what we live for.

**MADE IN USA**



## Specifications: Bones EX



Max = 35 lbs/16kg



3  
BIKE

Max = 105 lbs/48kg



## Optional Accessories:

#3037, 3040  
Bike Beam

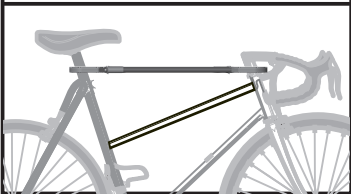

#3035  
Hatch Huggers

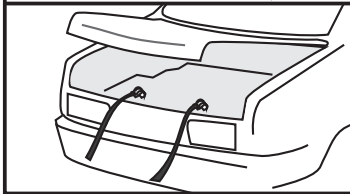

#3033  
Wheel Straps

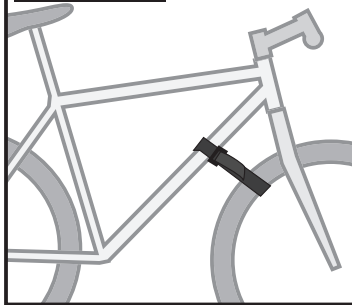

## RACK ORIENTATION

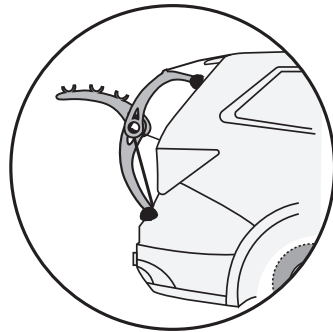
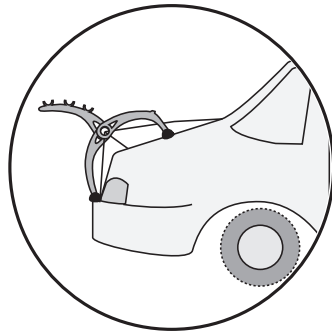
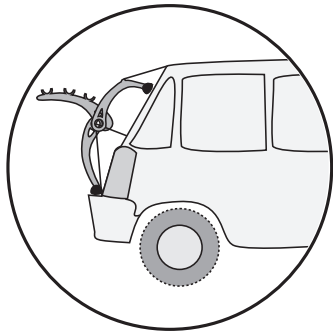
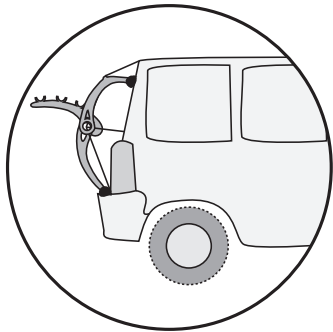

**EN** Bones EX can be configured for different vehicle types, as shown.

# OPENING RACK

1

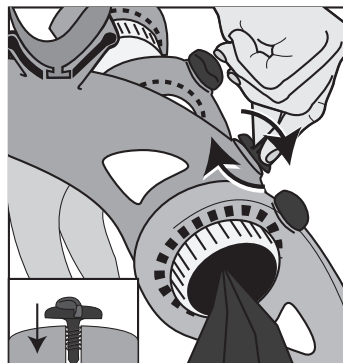
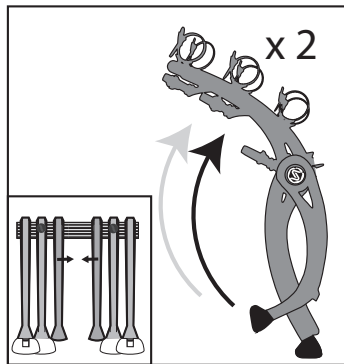
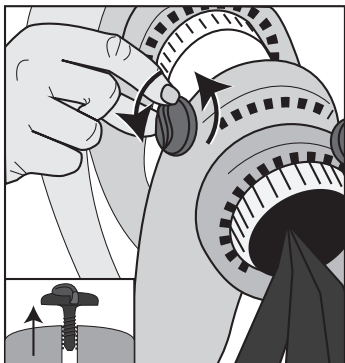

**EN** Turn knob on rack arm counterclockwise to loosen rack arm. Slide arm to center of aluminum tube and open arms as shown, slide arm back over aluminum tube spline. Tighten knob by turning clockwise.

## SETTING LEG POSITION

2

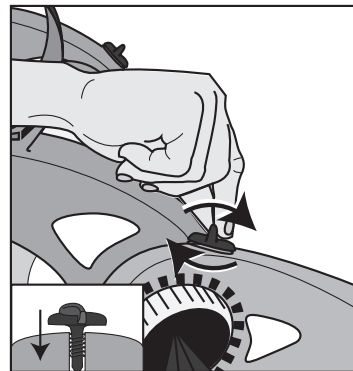
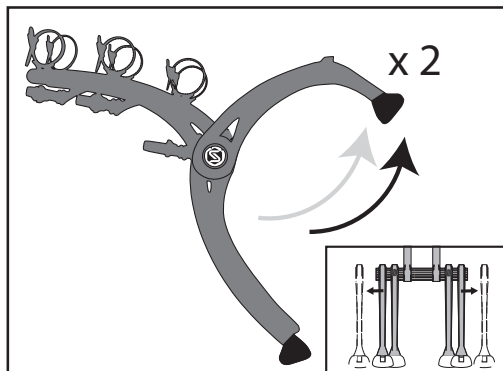
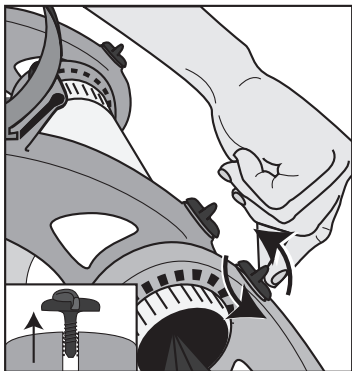

**EN** Turn knob counterclockwise on outer leg knob to loosen leg as shown. Remove leg from spline and reinstall on spline at desired position. Refer to page 6 to determine optimal rack orientation. Tighten knob.



## POSITIONING ON VEHICLE

3

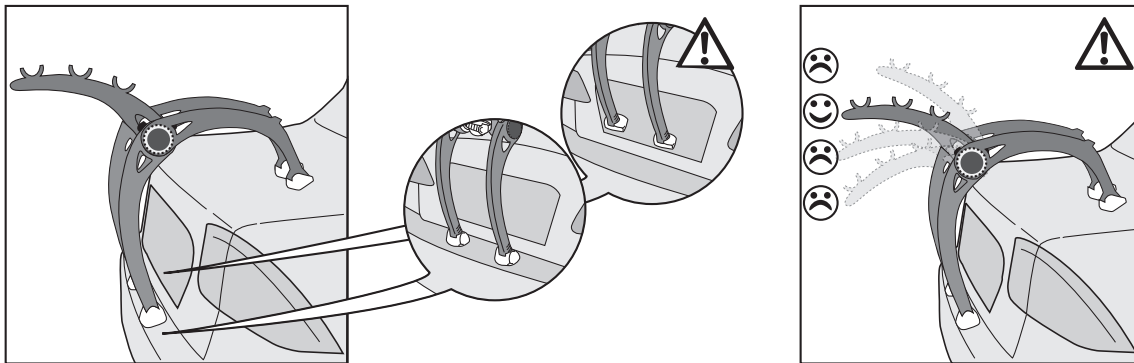

**EN** Place lower rack feet on bumper. Some vehicles require the feet to be on the trunk lid, refer to saris fit guide for proper feet placement on your vehicle. Place upper feet in center of trunk lid or center of rear window. Raise rack arms as shown. Note: bike cradles furthest from vehicle should be highest from the ground.

# ATTACHING STRAPS

4

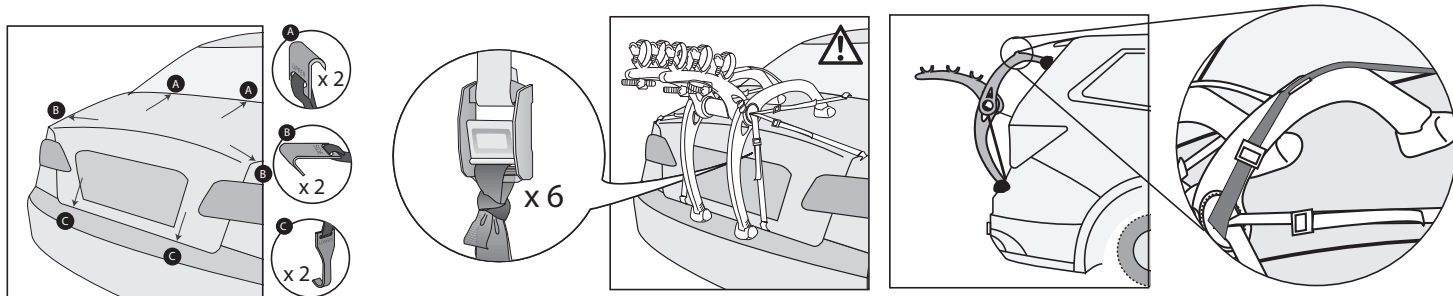

**EN** Install rack hooks in locations as shown. Hooks are labeled upper, side and lower. Upper hook straps can route through channels in upper legs. Reference fit guide on saris for recommended upper leg strap position. Tie off all straps as shown once thoroughly tightened.

## INSTALLING BIKES

5

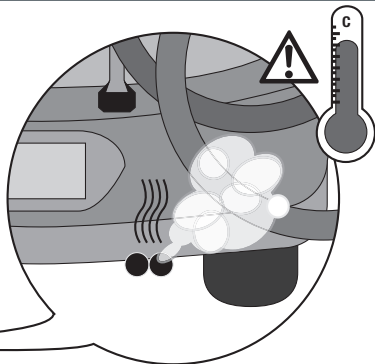
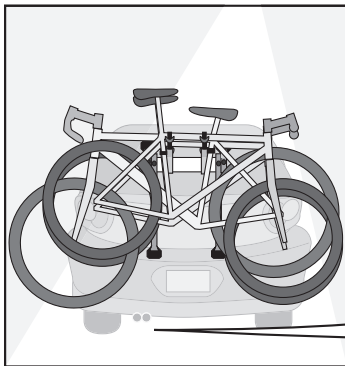
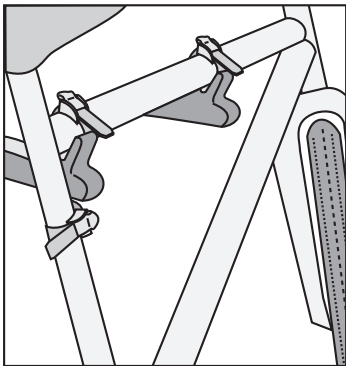

**EN** Install bike in rack cradles as shown. Lower anti-sway strap on arm should be positioned at the rear of the bike. Close straps and pull tight. Heaviest bikes should be installed closest to vehicle. Note: be aware of bicycle tire position in relation to vehicle exhaust. Be sure bike tires are at least 12" from ground. Do not open trunk or hatch with rack and/or bikes installed.

# PRECAUTIONS

6

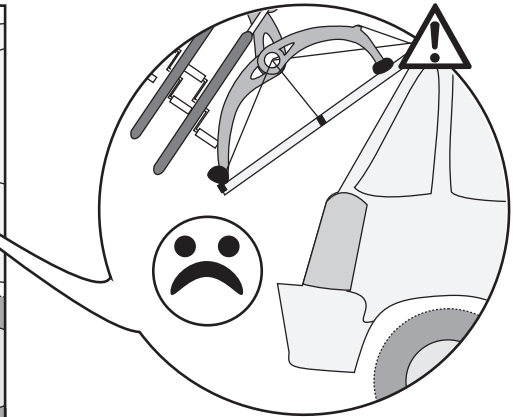
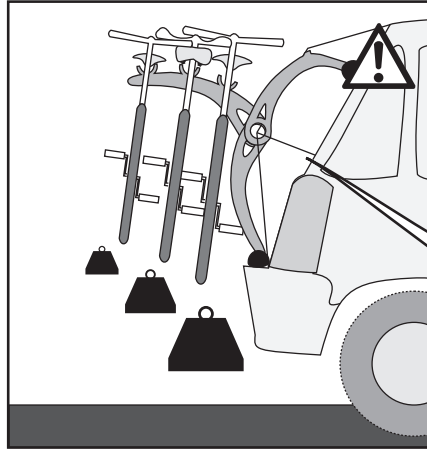
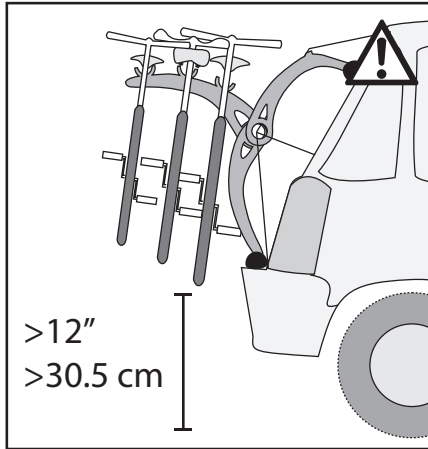

**EN** Bike carrier weight: 12lbs/5kg  
Permitted load capacity: max 105lbs/48 kg  
Max bike weight: 35 lbs/16 kg

**CAUTIONS:**

- All requirements for compatibility/fit as stated in the current Saris vehicle/carrier compatibility guide must be followed.
- Read and follow instructions carefully. Save owner's manual for future reference or parts information. Ensure that any other users of the bicycle carrier are familiar with their content.
- Drive slowly over speed bumps, 5 to 10 mph max speed.
- It's the end users responsibility to ensure that use of this product meets all local and state laws.
- When cleaning vehicle and rack, use only water soluble cleaners. Do not take rack through car wash.
- Make sure bike tires are not directly behind exhaust pipe.
- Do not mount to any type of trailer or RV including Class B vehicles.
- Prior to usage on the road, remove all loose parts from bicycle, including (but not limited to) child seat, basket, lock, light, pump, etc.
- This carrier is not recommended for off-road use or for use at speed exceeding 70 mph (113 km/h).
- The handling characteristics of a vehicle will change when a rear bicycles carrier is fitted and especially when it is loaded (in particular crosswind sensitivity, handling on bends and braking). Driving techniques should be altered to allow for these changes, reduce speed, especially on bends and allowing for longer braking distances.
- The vehicle's total length increases when the bike carrier is attached. The bikes themselves may increase the vehicle's total width and height. Take care when reversing and/or entering garages or ferries, etc.
- Remove carrier from vehicle when not in use.
- This carrier is constructed to carry standard-bike-frames. It is not intended for use with tandem or recumbent bicycles.
- Replace any mounting strap at the first sign of wear.
- Tighten straps regularly during the journey.

- Do not exceed maximum load capacity of carrier (105 lbs max or 35 lbs max per bike!) Secure properly and adjust for even load distribution, loading the heaviest/biggest bike first and closest to the vehicle.
- Saris absolves itself of responsibility for any personal injuries or consequential damage to property or wealth caused by incorrect fitting or use.

#### LIMITATIONS

The foregoing warranties are in lieu of and exclude all other warranties not expressly set forth herein, whether expressed or implied by operation of law or otherwise. Other than as set forth above, SCG makes no warranty, whether express, implied or statutory, with respect to any product, including, but not limited to, warranties of reliability, merchantability fitness for a particular purpose, or those arising from any course of performance, dealing, usage or trade. SCG shall not be liable for incidental or consequential losses, damages or expenses in connection with its products. SCG's liability hereunder is expressly limited to the replacement of goods not complying with this warranty or, at SCG's election, to the repayment of an amount of the purchase price of the product in question. Some states do not permit the exclusion or limitation of implied warranties or incidental or consequential damages, so the preceding limitations and exclusions may not apply to you.

## EXCLUSIONS

- If consumer does not heed cautions listed in Instruction Manual, damage is not covered under warranty
- Impact/collision damage is not covered under warranty
- Cradles and strap damage due to improper arm placement are not covered under warranty
- Carrying anything other than a bicycle is not covered under warranty
- Rust is wear and tear and is preventable with rack maintenance
- Weather impact (UV, salt air/water)

## RECOMMENDED RACK MAINTENANCE

### Each use:

- Wipe down trunk rack feet
- Check straps for signs of wear
- Check bike cradles and wheel scoops
- Check for loose bolts

### Every 90 days actions

- Clean with water and mild soap
- Lubricate locks if applicable (use wet, oil based lubricant; NO WD-40)
- Grease hitch bolt threads
- Check for scratches in paint

Check out an excellent selection of bike racks we offer on our website.