



**SARIS**

Freedom EX - 2 Bike

4412F

**TELL US WHAT YOU THINK**



REGISTER YOUR PRODUCT FOR UPDATES



## LONG FOR THE RIDE

Just as no garage is complete without a bicycle, at Saris, we believe no car is complete without a bike rack.

Since setting off on this journey nearly 30 years ago, Saris racks have freed millions of bike-lovers to explore new territory and terrain, take part in group rides, bike pool to races, and commute to and from work.

And we continue to do so in style.

As the all-time #1 best-selling bike rack, Saris Bones® continues to set the standard for excellence in design. Today all Saris bicycle racks are intuitive to load and secure, and guaranteed for life.

Built by cyclists for cyclists in Madison, Wisconsin, we strive to create the world's best bike racks.

Because cycling is what we live for.



## Specifications: 4412F



Max = 60 lbs/kg 27



Max = 120 lbs/54kg

## Tools Needed:

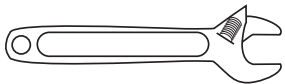

Adjustable or 19mm and 17mm

## Items Included:

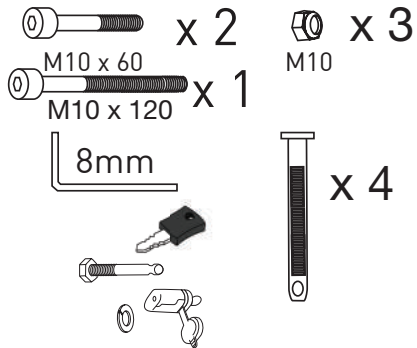

## Optional Accessories:

### #4419 Fat Tire Wheel Trays

Fits up to 5" tires

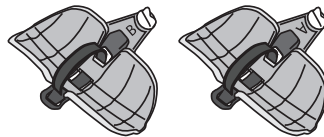

# INSTALL RACK

1

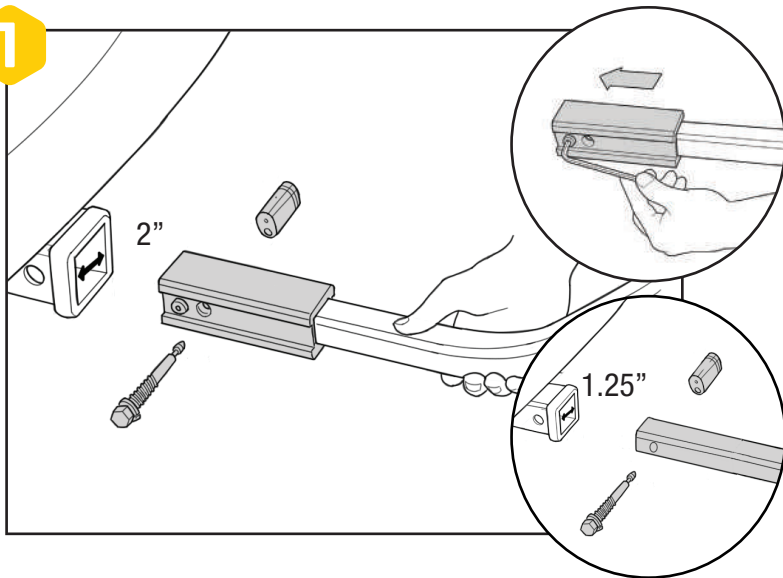

- EN** Install receiver and secure with pin and lock.  
Note: If your receiver is 1.25" remove the adapter block as shown.  
Tools Required: 19mm (3/4") wrench, 5mm hex key (to remove adapter block)

2

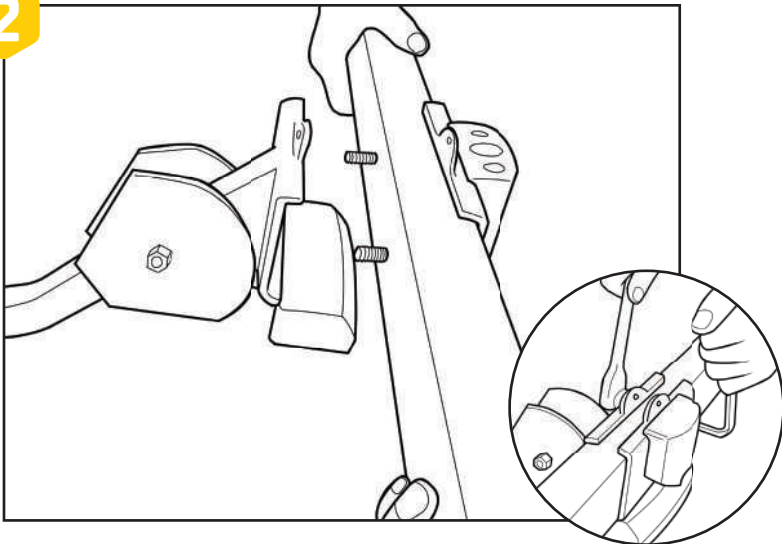

**EN** Lay horizontal bar on to receiver plate, lining up front plate with bar and receiver. Secure with bolts & nuts, using 17mm (9/16") wrench and 8mm hex key.

NOTE : Remove rubber tips

Tools Required: 17mm wrench, 8mm hex key

3

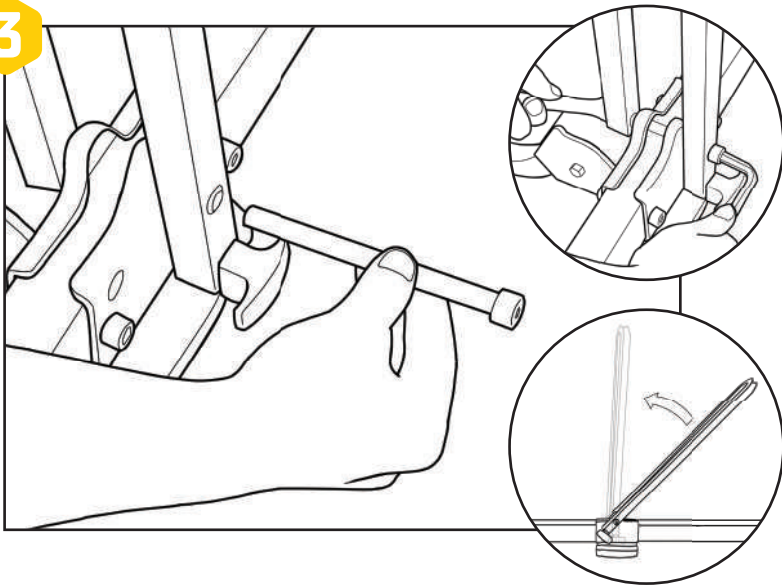

**EN** Secure upright with M10 x 120 bolt and nut using 17mm (9/16") wrench and 8 mm hex key.

Tools Required: 17mm wrench, 8mm hex key



4

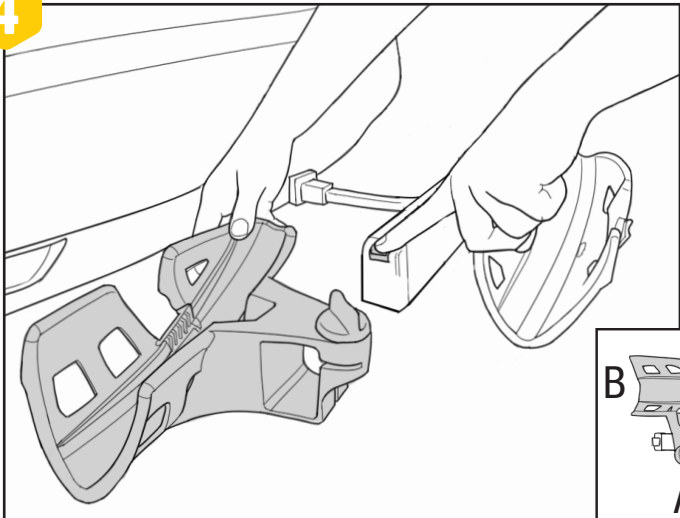

**EN** Slide on outer wheel trays to complete rack assembly. (Wheel tray with white reflectors installed on passenger side of vehicle facing away from the vehicle.)

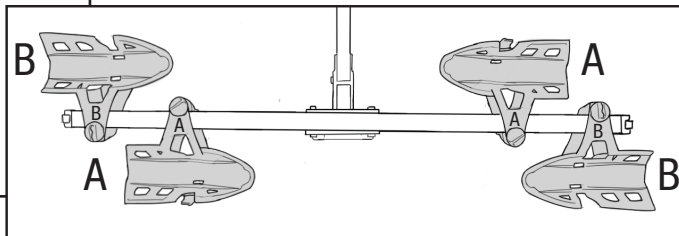

# LOAD BIKES

1

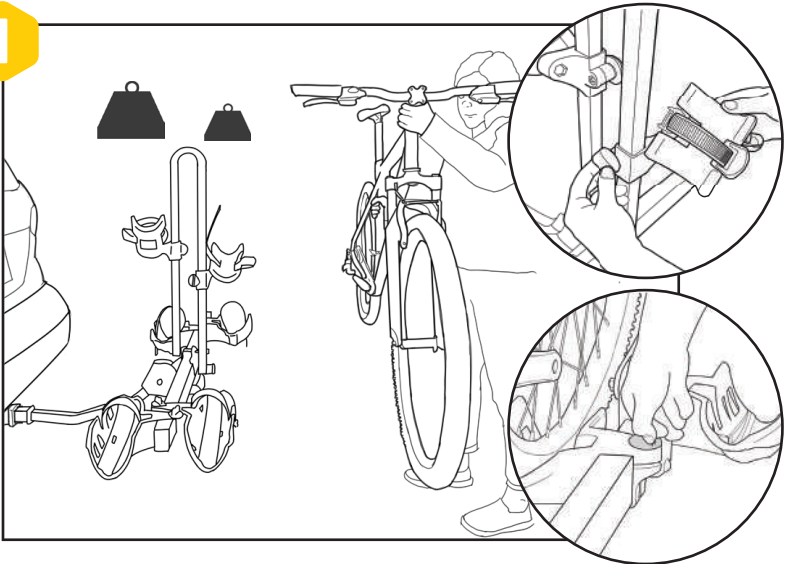

**EN** Load bikes. Heaviest bike closest to car. Adjust wheel tray if necessary. Tighten wheel tray knob.

2

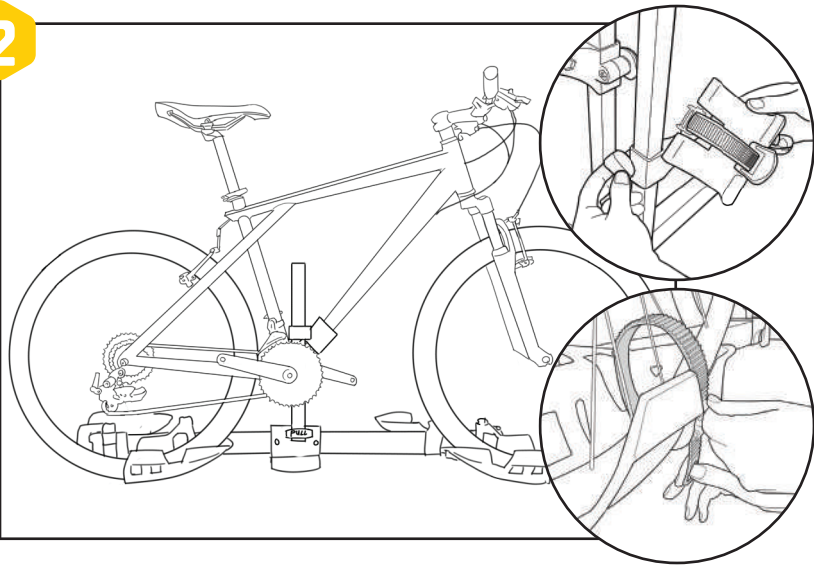

**EN** Secure bike wheel straps and down tube cradle.

3

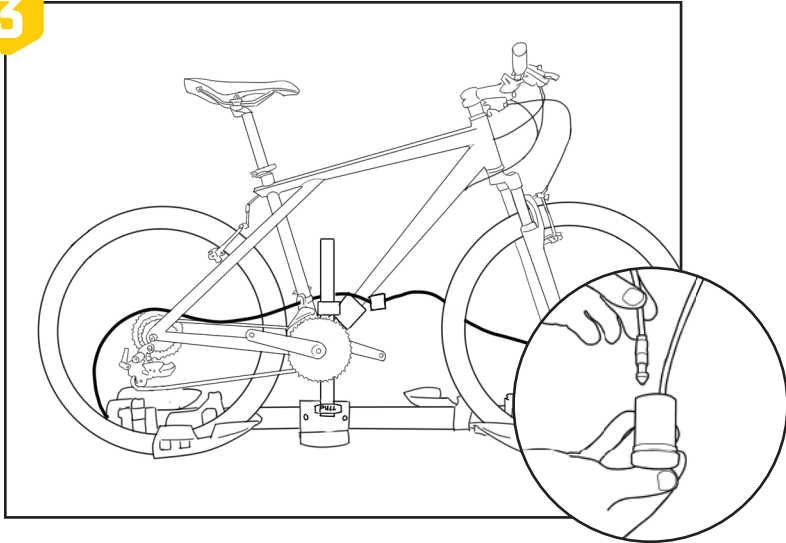

**EN** To lock bikes, use provided locking cable to lock bikes to vehicle's hitch.

## HATCH ACCESS

1

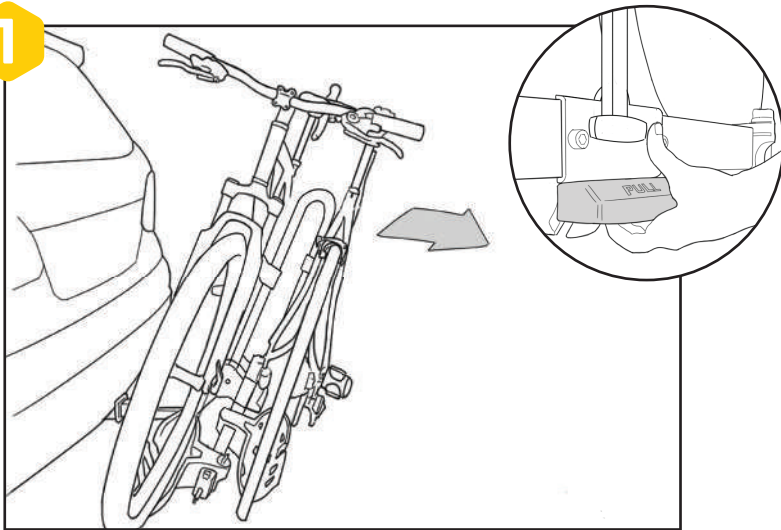

**EN** Pull handle, tilt rack away from vehicle.  
Caution: hold bikes with available hand.

2

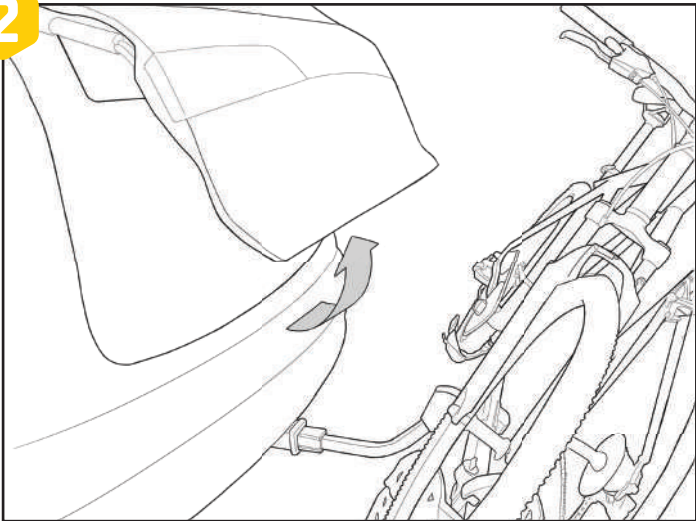

EN Access Hatch.

3

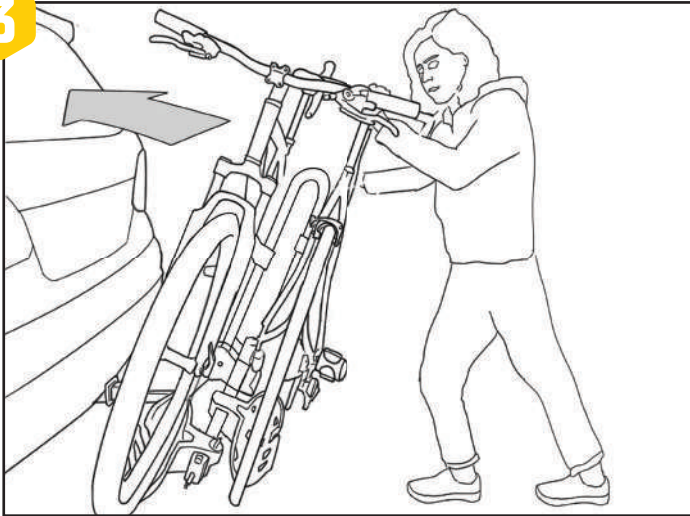

**EN** Push rack into place. You will hear audible “click” when in place.

# RACK STORAGE

1

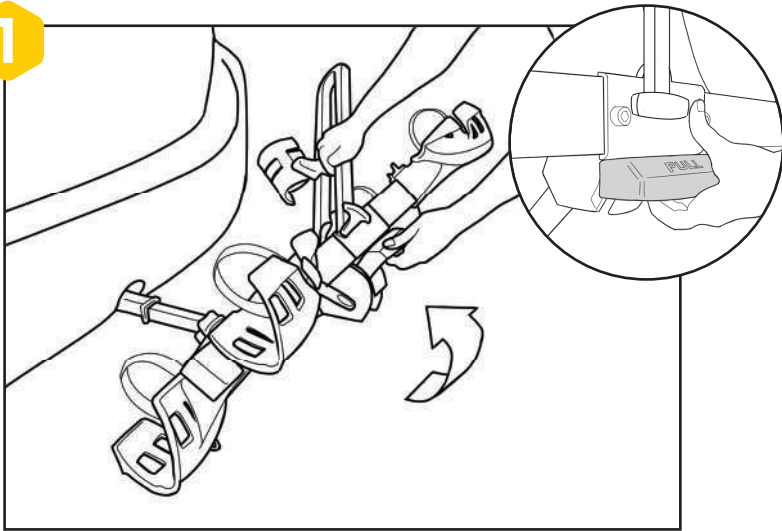

EN Pull handle, Fold up rack toward vehicle



## EN Technical Specifications

Bike carrier weight: 26lb/ 11.8kg

Permitted load capacity: 120lb/ 54.4kg

Max bike weight: 60 lb/27.2 kg

### CAUTIONS:

- All requirements for compatibility/fit as stated in the current Saris vehicle/carrier compatibility guide must be followed. (Available at any Saris dealer). If your vehicle is not listed or you have any questions, please call our customer service.
- Read and follow instructions carefully. Save owner's manual for future reference or parts information. Ensure that any other users of the bicycle carrier are familiar with their content.
- Drive slowly over speed bumps, 5 to 10 mph max speed.
- It's the end users responsibility to ensure that use of this product meets all local and state laws.
- When cleaning vehicle and rack, use only water soluble cleaners. Do not take rack through car wash.
- Make sure bike tires are not directly behind exhaust pipe.
- Do not mount to any type of trailer, towed vehicle, RV.
- Do not use with hitch extender.
- Prior to usage on the road, remove all loose parts from bicycle, including (but not limited to) child seat, basket, lock, light, pump, etc.
- This carrier is not recommended for off-road use or for use at speed exceeding 70 mph (113 km/h).
- The handling characteristics of a vehicle will change when a rear bicycles carrier is fitted and especially when it is loaded (in particular crosswind sensitivity, handling on bends and braking). Driving techniques should be altered to allow for these changes, reduce speed, especially on bends and allowing for longer braking distances.
- The vehicle's total length increases when the bike carrier is attached. The bikes themselves may increase the vehicle's total width and height. Take care when reversing and/or entering garages or ferries, etc.
- Remove carrier from vehicle when not in use.
- This carrier is constructed to carry standard-bike-frames. It is not intended for use with tandem or recumbent bicycles.
- Replace any mounting strap at the first sign of wear. Replacement parts are available through your local Saris dealer.

- Tighten straps regularly during the journey.
- Vehicle should be in good condition in the area at which the hitch is located.
- Do not exceed maximum load capacity of carrier (120 lbs max or 60 lbs max per bike!) Secure properly and adjust for even load distribution, loading the heaviest/biggest bike first and closest to the vehicle.
- Saris absolves itself of responsibility for any personal injuries or consequential damage to property or wealth caused by incorrect fitting or use.

**Warning and Disclaimer:**

This carrier has been designed to carry bicycles on specific vehicles. Before installation, user must read and follow current Saris Fit Guide (available through Saris dealer) recommendations and enclosed instructions. Fit recommendations are based on vehicle's standard features; optional features may affect the fit recommendations. User must attach carrier correctly to the vehicle, check its attachment before each use, and inspect carrier parts for wear. Carrier's attachment to the vehicle is critical and beyond the control of the manufacturer. Manufacturer and seller expressly disclaim any and all liability for personal injury, property damage or loss, whether direct, indirect, or incidental, resulting from the incorrect attachment, improper use, inadequate maintenance, or neglect of this carrier.

Any product or part thereof found to be defective within the term as set forth above will be replaced without charge provided that: (1) its failure resulted from a defect in material or workmanship and not from normal wear and tear expected in the use of the product; (2) the product was not misused, improperly assembled, improperly maintained or damaged by accident; (3) there was no failure to follow instructions or warnings in Owner's Manual; (4) no alterations or modifications were made; and (5) the product or part is delivered, freight prepaid, to Saris Cycling Group or an authorized service center. SCG reserves the right to inspect any product before issuing a replacement. SCG's only obligation shall be to replace such products or parts that it determines are defective.

## LIMITATIONS

The foregoing warranties are in lieu of and exclude all other warranties not expressly set forth herein, whether expressed or implied by operation of law or otherwise. Other than as set forth above, SCG makes no warranty, whether express, implied or statutory, with respect to any product, including, but not limited to, warranties of reliability, merchantability fitness for a particular purpose, or those arising from any course of performance, dealing, usage or trade. SCG shall not be liable for incidental or consequential losses, damages or expenses in connection with its products. SCG's liability hereunder is expressly limited to the replacement of goods not complying with this warranty or, at SCG's election, to the repayment of an amount of the purchase price of the product in question. Some states do not permit the exclusion or limitation of implied warranties or incidental or consequential damages, so the preceding limitations and exclusions may not apply to you.

## EXCLUSIONS

- If consumer does not heed cautions listed in Instruction Manual, damage is not covered under warranty
- Impact/collision damage is not covered under warranty
- Cradles and strap damage due to improper arm placement are not covered under warranty
- Carrying anything other than a bicycle is not covered under warranty
- Rust is wear and tear and is preventable with rack maintenance
- Weather impact (UV, salt air/water)

## RECOMMENDED RACK MAINTENANCE

Each use:

- Wipe down trunk rack feet
- Check straps for signs of wear
- Check bike cradles and wheel scoop
- Check for loose bolt

Every 90 days actions

- Clean with water and mild soap
- Lubricate locks if applicable (use wet, oil based lubricant; NO WD-40)
- Grease hitch bolt thread
- Check for scratches in paint