



SARIS

SuperClamp EX - 2 Bike

4025F

TELL US WHAT YOU THINK



REGISTER YOUR PRODUCT FOR UPDATES



LONG FOR THE RIDE

Just as no garage is complete without a bicycle, at Saris, we believe no car is complete without a bike rack.

Since setting off on this journey nearly 30 years ago, Saris racks have freed millions of bike-lovers to explore new territory and terrain, take part in group rides, bike pool to races, and commute to and from work.

And we continue to do so in style.

As the all-time #1 best-selling bike rack, Saris Bones® continues to set the standard for excellence in design. Today all Saris bicycle racks are intuitive to load and secure, and guaranteed for life.

Built by cyclists for cyclists in Madison, Wisconsin, we strive to create the world's best bike racks.

Because cycling is what we live for.



Specifications: 4025F SuperClamp EX



For use with receiver hitches Class II or higher.



Max = 60 lbs/kg 27



Max = 120 lbs/54kg

Tools Needed:

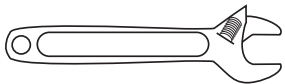

Adjustable or 19mm and 17mm

Items Included:

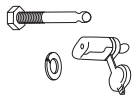
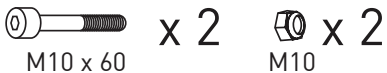

Optional Accessories:

#4419 Fat Tire Wheel Trays
For 4.5"-5" tires

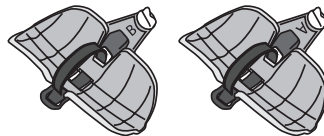

INSTALL RACK

1

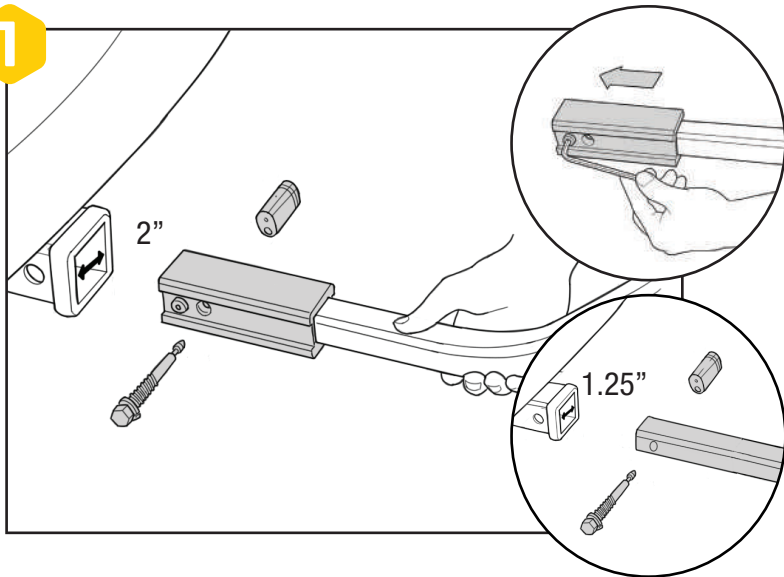

- EN** Install receiver and secure with pin and lock.
Note: If your receiver is 1.25" remove the adapter block as shown.
Tools Required: 19mm(3/4") Wrench, 5mm Hex Key(to remove adapter block)

2

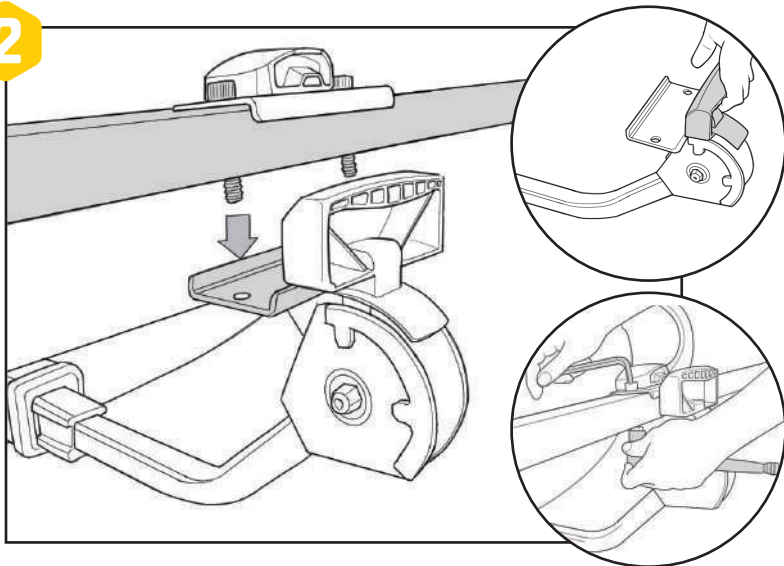

EN Lay horizontal bar on to receiver plate, lining up front plate with bar and receiver. Secure with bolts & nuts, using 17mm(9/16") wrench and 8mm hex key.

NOTE : Remove rubber tips

Tools Required: 17mm Wrench, 8mm Hex Key

3

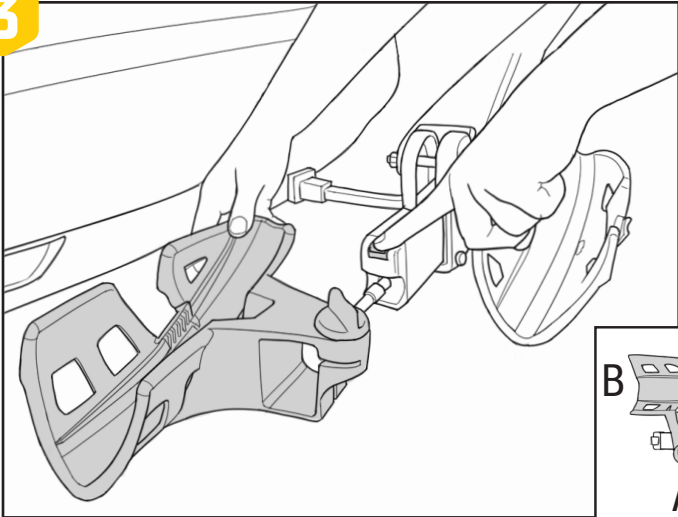

EN Slide on outer wheel trays to complete rack assembly. (Wheel tray with white reflectors installed on passenger side of vehicle facing away from the vehicle.)

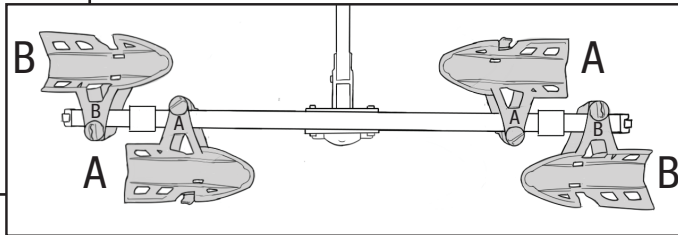

1

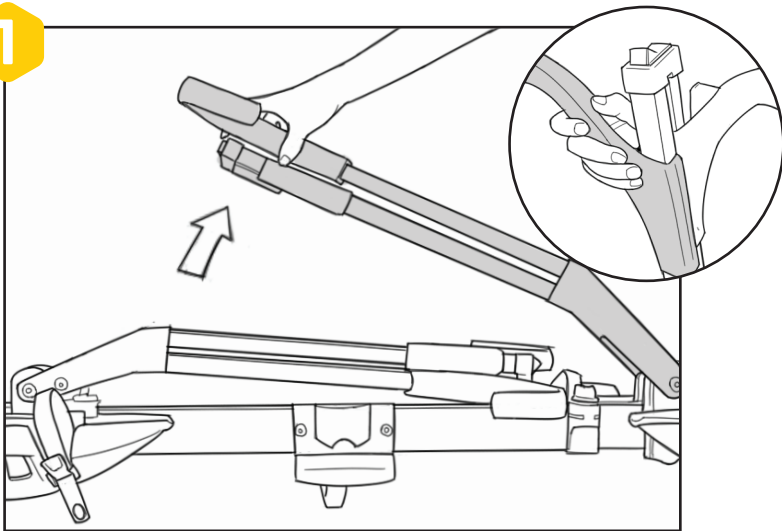

EN Push and hold button to open arm. Push and hold button to slide hooks up.

2

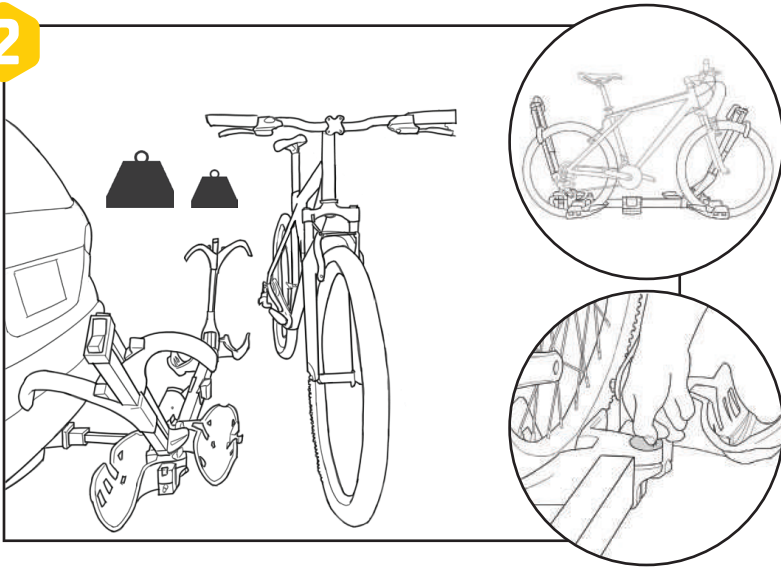

- EN** Load bikes. Heaviest bike closest to car. Adjust wheel tray if necessary. Tighten wheeltray knob.
NOTE: Position arms at “10:00” and “2:00” without contacting bike frame components.

3

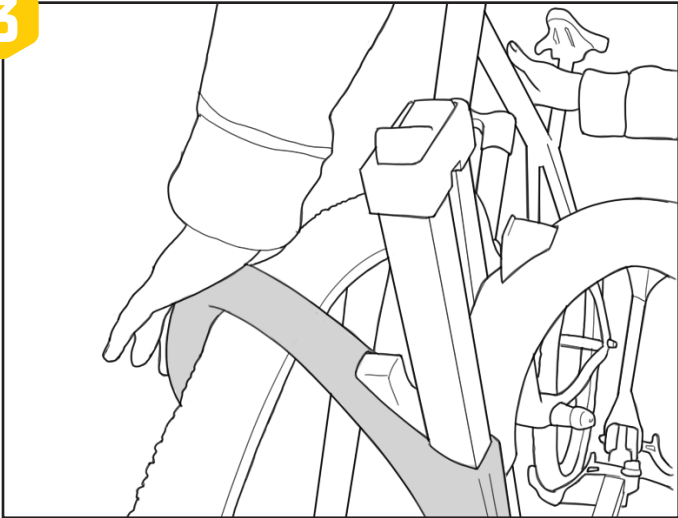

EN Press hooks down onto tires. Once the hook contacts the tire, firmly press the hook down until you hear 1 additional click. Ensure the tires are properly inflated and in good condition.

NOTE: For rear fender, 20" bikes, bikes over 50 lbs, wheel straps should be used in the «A» wheel trays(Back Wheel). Bikes between 45" - 48" wheelbase require two wheel straps.

4

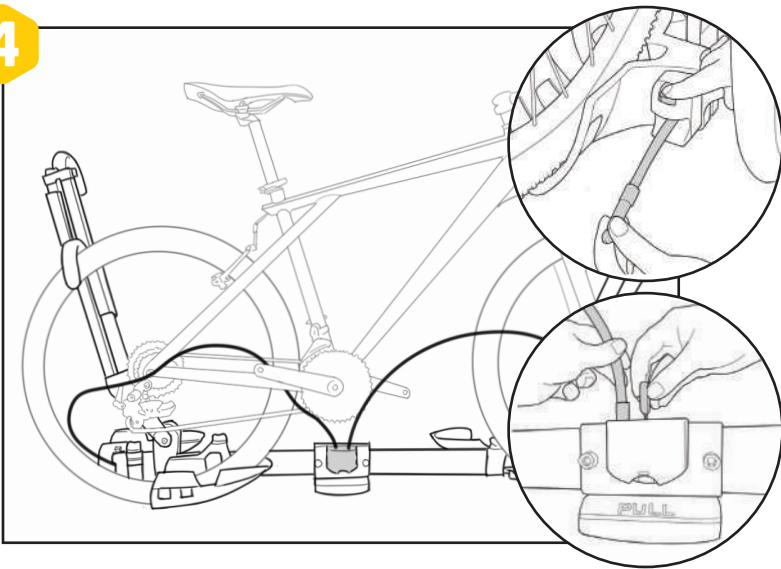

EN To lock bikes press and hold button, pull out lock shank. Be sure lock is in unlock position before inserting lock shank. To return cable press and hold button.

5

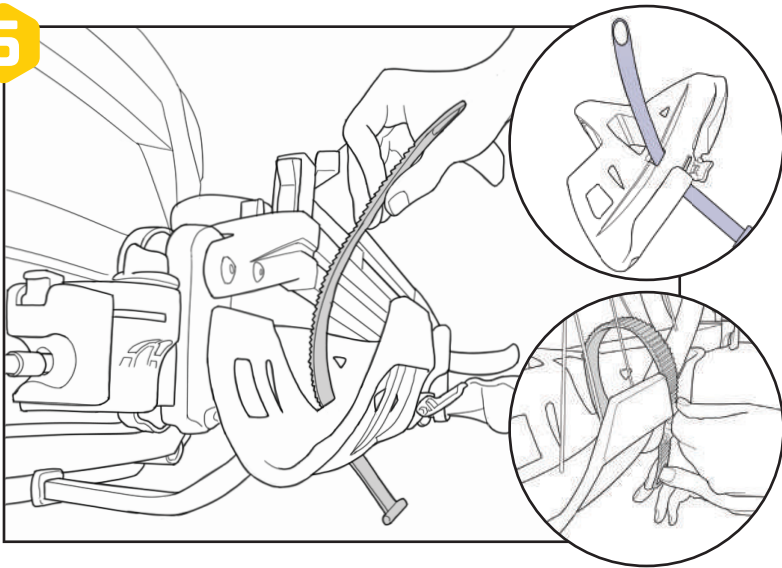

EN Thread Wheel Strap from bottom through strap slot. Click strap into place. Use Strap to secure rear wheel to tray.

HATCH ACCESS

1

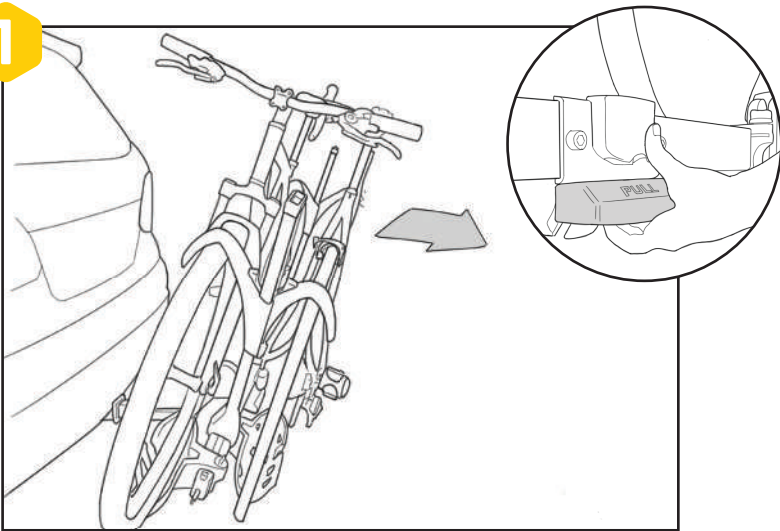

EN Pull handle, tilt rack away from vehicle.
Caution: hold bikes with available hand.

2

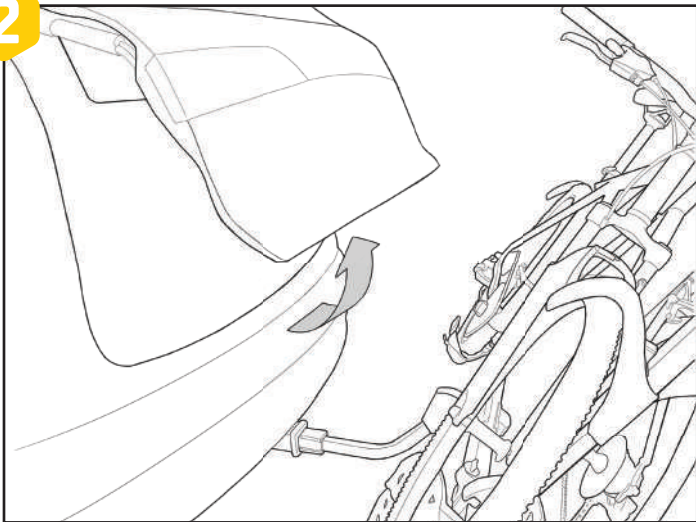

EN Access Hatch.

3

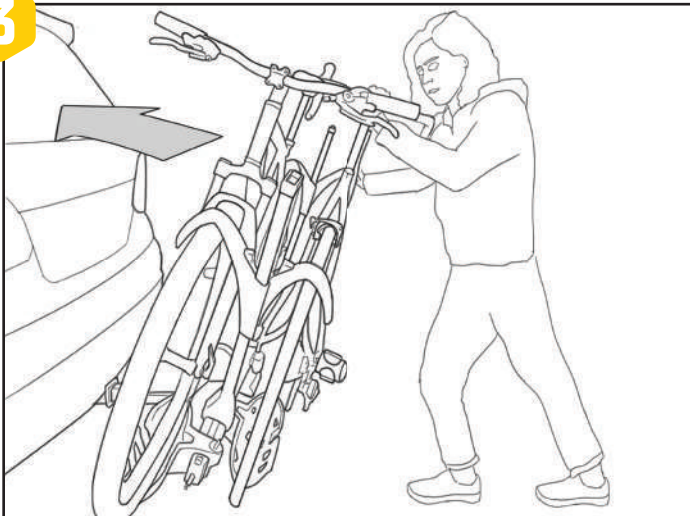

EN Push rack into place, you will hear audible “click” when in place.

RACK STORAGE

1

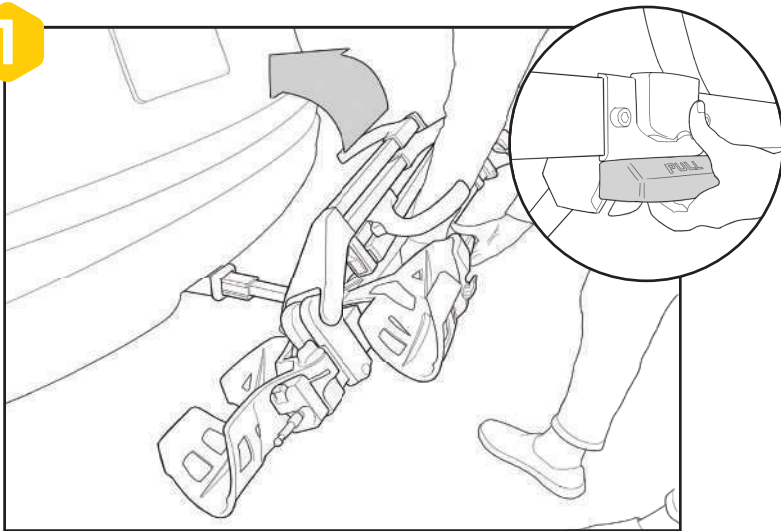

EN Pull handle, Fold up rack toward vehicle

EN Technical Specifications

Bike carrier weight: 35lb/ 15.8kg

Permitted load capacity: 120lb/ 54.4kg

Max bike weight: 60 lb/27.2 kg

CAUTIONS:

- All requirements for compatibility/fit as stated in the current Saris vehicle/carrier compatibility guide must be followed. (Available at any Saris dealer). If your vehicle is not listed or you have any questions, please call our customer service.
- Read and follow instructions carefully. Save owner's manual for future reference or parts information. Ensure that any other users of the bicycle carrier are familiar with their content.
- Drive slowly over speed bumps, 5 to 10 mph max speed.
- It's the end users responsibility to ensure that use of this product meets all local and state laws.
- When cleaning vehicle and rack, use only water soluble cleaners. Do not take rack through car wash.
- Make sure bike tires are not directly behind exhaust pipe.
- Rack must be installed directly into vehicle hitch receiver. Do not modify the hitch receiver or use hitch extenders.
- Do not mount to any type of trailer or RV including Class B vehicles.
- Prior to usage on the road, remove all loose parts from bicycle, including (but not limited to) child seat, basket, lock, light, pump, etc.
- This carrier is not recommended for off-road use or for use at speed exceeding 70 mph (113 km/h).
- The handling characteristics of a vehicle will change when a rear bicycles carrier is fitted and especially when it is loaded (in particular crosswind sensitivity, handling on bends and braking). Driving techniques should be altered to allow for these changes, reduce speed, especially on bends and allowing for longer braking distances.
- The vehicle's total length increases when the bike carrier is attached. The bikes themselves may increase the vehicle's total width and height. Take care when reversing and/or entering garages or ferries, etc.
- Remove carrier from vehicle when not in use.
- This carrier is constructed to carry standard-bike-frames. It is not intended for use with tandem or recumbent bicycles.
- Replace any mounting strap at the first sign of wear. Replacement parts are available through your local Saris dealer or call.

- Tighten straps regularly during the journey.
- Vehicle should be in good condition in the area at which the hitch is located.
- Do not exceed maximum load capacity of carrier (120 lbs max or 60 lbs max per bike!) Secure properly and adjust for even load distribution, loading the heaviest/biggest bike first and closest to the vehicle.
- Saris absolves itself of responsibility for any personal injuries or consequential damage to property or wealth caused by incorrect fitting or use.

Warning and Disclaimer:

This carrier has been designed to carry bicycles on specific vehicles. Before installation, user must read and follow current Saris Fit Guide (available through Saris dealer) recommendations and enclosed instructions. Fit recommendations are based on vehicle's standard features; optional features may affect the fit recommendations. User must attach carrier correctly to the vehicle, check its attachment before each use, and inspect carrier parts for wear. Carrier's attachment to the vehicle is critical and beyond the control of the manufacturer. Manufacturer and seller expressly disclaim any and all liability for personal injury, property damage or loss, whether direct, indirect, or incidental, resulting from the incorrect attachment, improper use, inadequate maintenance, or neglect of this carrier.