



IMPORTANT:

When available, be sure to use the vehicle manufacturer's provisions to attach belts. When you use the manufacturer's threaded floor fittings, it is **IMPORTANT** that all full threads be engaged to obtain the ultimate strength of the anchorage. Reuse factory mounting bolts or use 7/16th" grade 5 or higher bolts.

CAUTION:

Do not attach this belt directly to the seat. Death or serious injury could occur in an accident if the seat is not designed to withstand the additional load. **FLOOR MOUNT ONLY!**

Installation Instructions:

1. Mount the short side of the belt **INBOARD**, toward the center of the vehicle.
2. Avoid rough or sharp edges when choosing a belt path.

WHERE NO FACTORY FITTINGS ARE AVAILABLE:

1. If the seat is adjustable, move to the rearmost position.
2. Mark the floor to mount down and behind the seat to assure that the lap belt is pulling downward and rearward at approximately a 70 degree angle. (Figure 1)
3. Space the attachment points 15" to 25" apart so that the lap belt forms a "U" shaped loop when in use. (Figure 2) Never attach both ends of the same lap belt to the same anchorage or attachment point.
4. Carefully drill 1/2" holes to avoid damaging exhaust system, brake or fuel lines. Always use the reinforcement plates (sold separately- part number SBHP, SKU# 12186) underneath the floor. (Figure 3) Examine and reinforce any weakened area of the floor pan.

Figure 1.

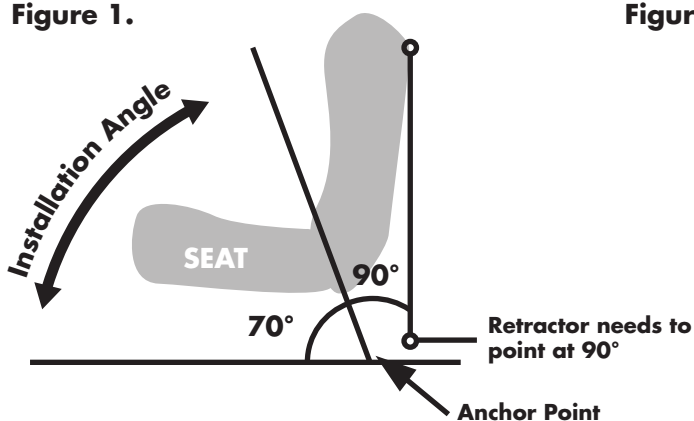
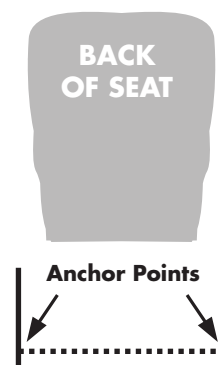

Figure 2.



**Anchor points:
Minimum of 15" apart
Maximum of 25" apart**



IMPORTANT:

1. For lap seat belts, mounting hardware to the floor should always have metal-to-metal contact. You should avoid carpet, plastic or any other material between the lap seat belt fastener components and the floor which could tend to loosen over time.
2. All bolts must have either a lock-nut, lock washer or apply a thread locking compound for security.
3. Bolts used for mounting seatbelts should be a minimum size 7/16" diameter, Grade 5 product.
4. Anchor points for belts must meet the strength load requirements of FMVSS 210. When replacing belts, always use the anchorages provided by the vehicle, or seat manufacturer.
5. Do not connect both ends of this belt to the same, single mounting point. Mounted ends of the belt should form a "U" shape.

Figure 3.

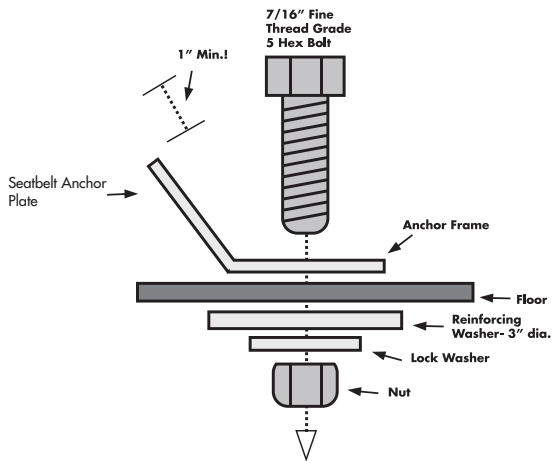

Mounting Seat Belt Anchors to the Floor

Figure 4.

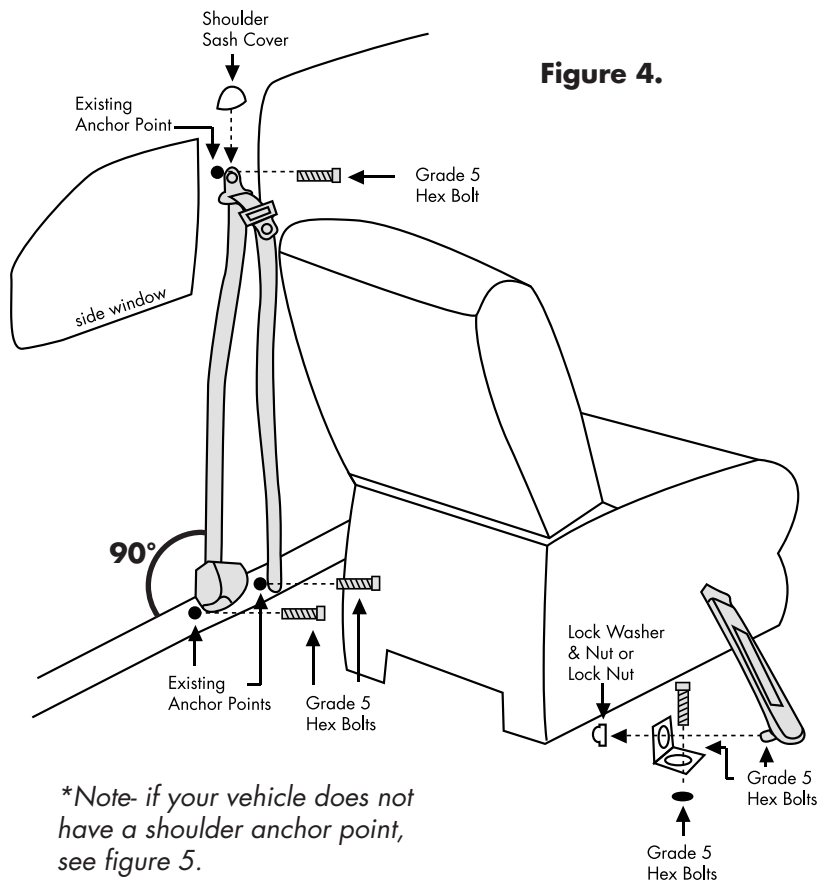



Creating a Shoulder Anchor Point

To create a shoulder anchor point, remove anything covering the metal. Find a spot on your B-pillar between 0 and 8 inches above the top of the seat and slightly behind it for the anchor.

Mounting Plate

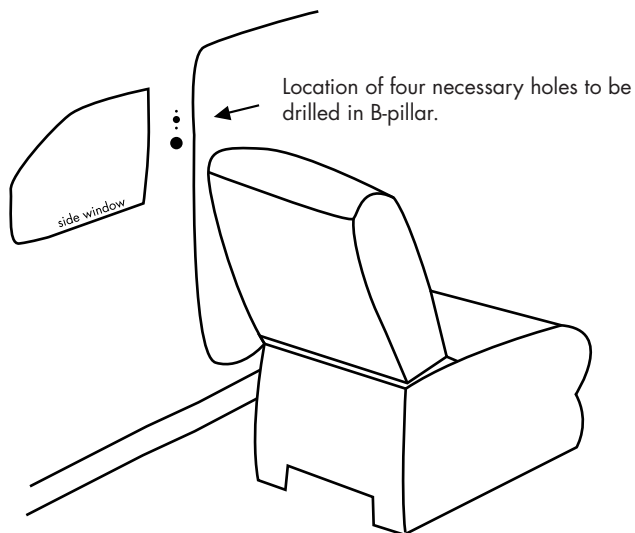
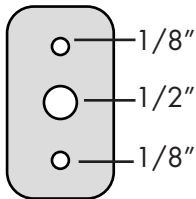

Mark out four holes. Using the anchor plate itself as a template, mark the holes for the anchor plate and a 1 1/2" hole below it. You will use this hole to insert the anchor plate behind the interior metal of your B-pillar. The 1/8" holes are for rivets to hold the plate in place, and the 1/2" hole is for the seatbelt anchor bolt.

Once the anchor plate is in place, you will need to drill a 1/2" hole in any interior trim that covers your B-pillar. Measure carefully so all the 1/2" holes align perfectly. If you do not have any trim, a 1 1/2" plastic plug will fill the large hole, or you can plan to have the hole covered by the seatbelt webbing once installed.

Figure 5- Creating Shoulder Anchor Point

Note: The user assumes all risk of determining a safe location for the anchor point. In some applications this point may be above the rear window.

Figure 6- Anchor Point in Convertibles

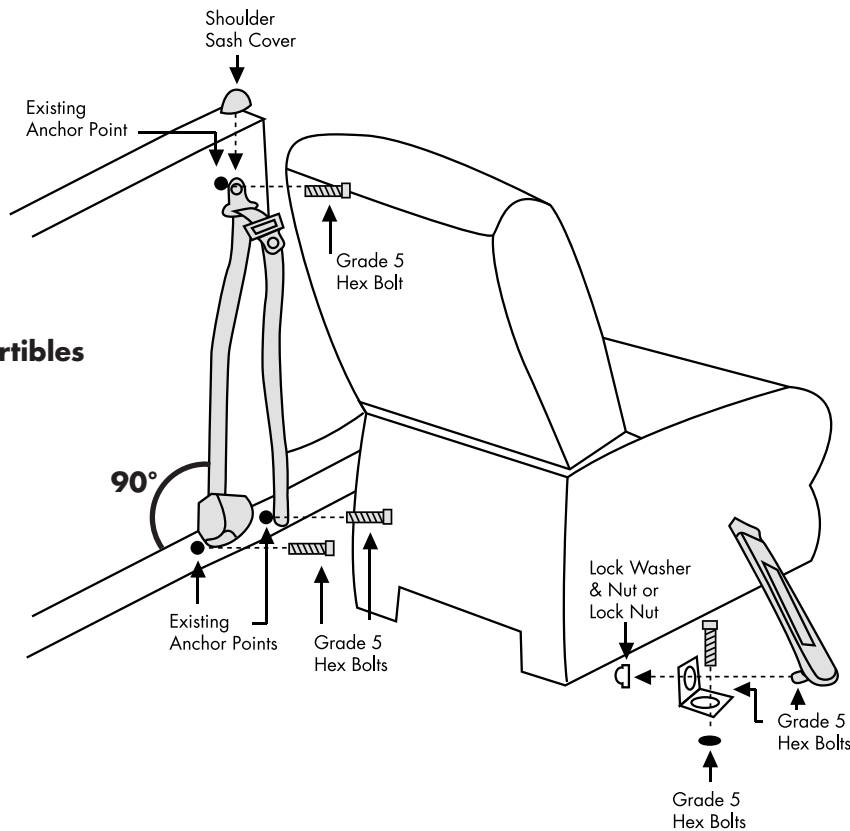

USER GUIDE AND INSTALLATION MANUAL

STBSB3R 3-POINT RETRACTABLE BELT



Seat Belt Use

1. Always wear your seat belt when the vehicle is in operation.
2. Adjust and wear belt low and snug across your hips.
3. Each belt is intended to restrain only one person at a time. Do not put two people under one belt.
4. Never attempt to restrain a child in your lap using the lap belt around both you and the child. The child could be severely injured or even killed in the event of a collision.
5. Seat Belts are matched sets. Do not mix or use this belt or parts of this belt with other types of seatbelts.

Use and Maintenance Instructions

Print and keep this instruction sheet for future review.

WARNING:

FAILURE TO PROPERLY INSTALL, USE, PERIODICALLY INSPECT AND MAINTAIN THIS SEAT BELT COULD LEAD TO SERIOUS INJURY OR DEATH! PLEASE FOLLOW ALL OF THE IMPORTANT INFORMATION BELOW:

Maintenance

1. Inspect belt regularly. If the assembly does not work properly or you find cuts, frayed or worn webbing the belt must be replaced.
2. More frequent inspections may be necessary if the belt is subjected to harsh treatment or extreme conditions.
3. Whenever a vehicle is involved in a collision you must replace every part of the seat belt system; both sides of the belt including the mounting hardware!
4. Clean with mild soap and water. Do not bleach or re-dye as it will tend to severely weaken the webbing.

Universal Installation Information:

If the vehicle is equipped with seat belt anchorages, these should be used in lieu of other methods. All U.S. passenger cars, beginning with 1962 models, have seat belt anchorages for at least two lap belts in the front seat. Since 1/1/68, vehicle manufacturers have been required to install lap belt anchorages for each front and rear seating positions and upper torso belt anchorages at each forward facing outboard seating position (except convertibles). Since 1/1/72, this same requirement became effective for trucks.

CAUTION: DEATH OR SERIOUS INJURY COULD RESULT FROM NOT PROPERLY THREADING THE WEBBING THROUGH THE ADJUSTABLE ENDS. MAINTAIN A MINIMUM OF ONE INCH WEBBING BEYOND THE ANCHOR. (SEE FIG. 3)

CAUTION: IF THE FIXED END OF A SEATBELT IS TOO LONG TO ALLOW A SNUG FIT ON A SMALL OCCUPANT, DO NOT USE THE BELT! YOU MUST SHORTEN THE BELT THROUGH THE ADJUSTABLE ANCHOR ENDS TO ALLOW A PROPER FIT.

AS A GENERAL RULE, CHILDREN WEIGHING LESS THAN 80 LBS SHOULD BE SECURED IN AN APPROVED CHILD SAFETY/BOOSTER SEAT ACCORDING TO MANUFACTURER'S RECOMMENDATIONS!!!



STBSB2RS, STBSB2RA, STBSB3RS, STBSB3RA

IS YOUR BELT STUCK?

RETRACTABLE SEAT BELT RESET GUIDE

THIS GUIDE SHOULD WORK FOR ALL RETRACTING SEAT BELTS





1.) Take the seat belt and mount/hold in a **vertical position** as seen below. If possible use a bench vice to hold the unit up right.



It is important that the belt is in a vertical position.



2.) With the seat belt held upright, locate the safelock gear, which should be located on the right hand side of the unit, next to the belt.

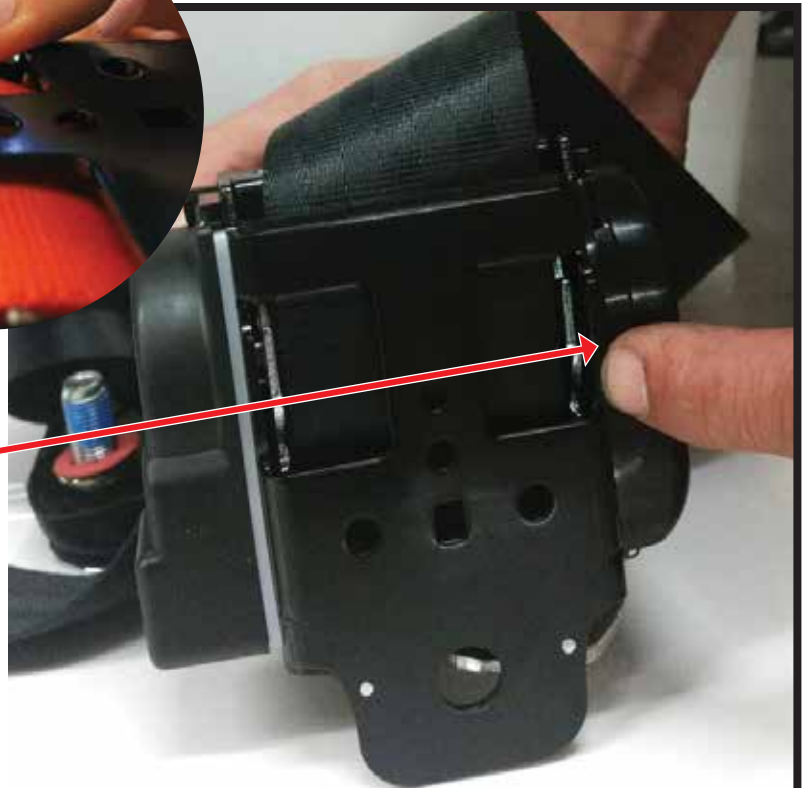
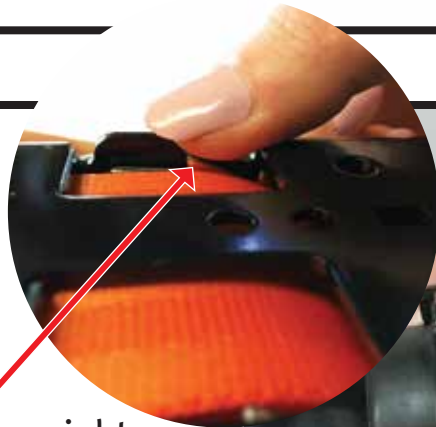



3.) If possible, use your thumb/s to roll the belt further down into itself, until you hear a faint click, or after a half turn. Then stop, as it should be unlocked (super quiet click). If needed, you can use a small flat head on the safelock gear to turn the gear shown by the blue arrow.



4.) Once unlocked, slowly pull the belt out of the retractor, at least half way, as it is now completely unjammed. Avoid letting it retract all the way back in again.

Congratulations! Your belt is now reset and ready for installation.

