



OMIX-ADA, Inc.

Part #11546.52

HD Wheel Mount

CONTENTS:

- Main Plate (1)
- Lug Plate (1)
- Brake Light Extender (1)
- Spacer Plates (2)

HARDWARE:

- M6 Bolt (4)
- M6 Washer (8)
- M6 Lock Nut (4)
- M8 Bolt (8)
- M8 Washer (8)
- M12 Bolt (4)
- M12 Washer (8)
- M12 Lock Nut (4)
- M12 Set Screw (2)
- #10 Phillips Screw - Long (2)
- #10 Phillips Screw - Short (2)
- Lug Nuts (3)
- Butt Connectors (4)
- Wire (2)

TOOLS REQUIRED:

- Socket Wrench
- 13mm Socket
- 10mm Socket
- 10mm Wrench
- 19mm Socket
- 19mm Wrench
- 3/4" Deep Socket
- Torque Wrench
- 6mm Allen Wrench
- T-20 Torx bit
- Phillips Head Screwdriver
- Wire Cutters/Crimpers

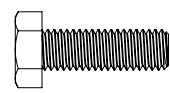
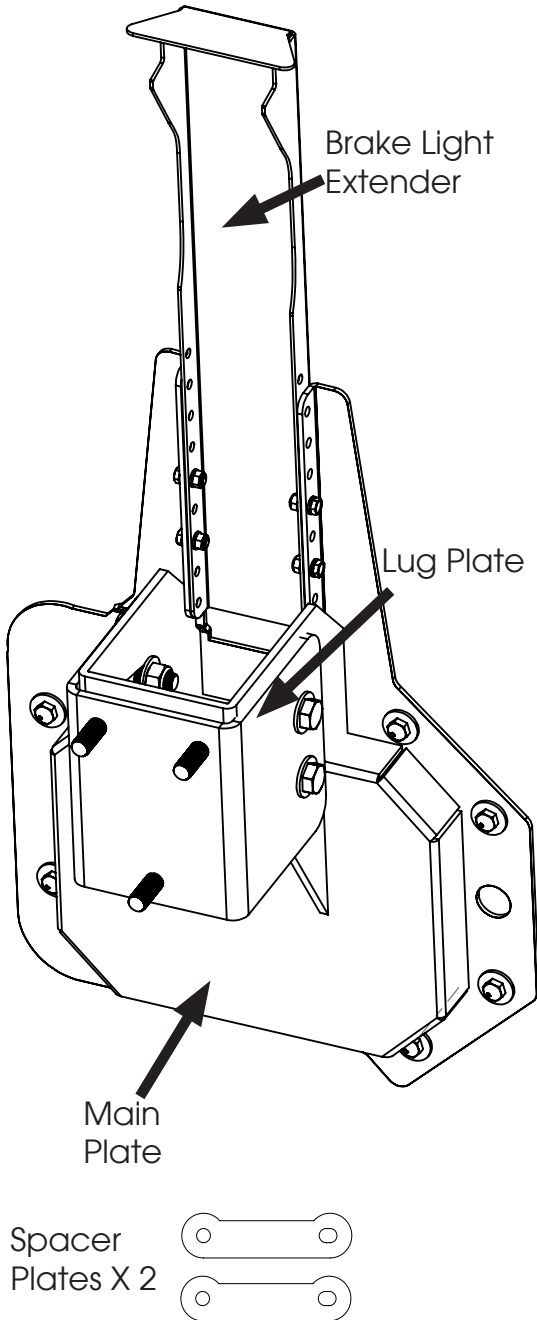

M6 Bolt X 4



M6 Washer X 8



M6 Lock Nut X 8

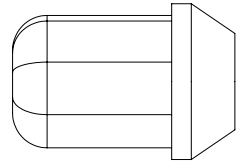

Lug Nut X 3



M8 Bolt X 8

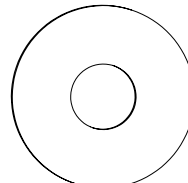

M8 Washer X 8

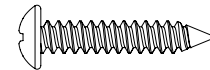

#10 Phillips Screw - Short X 2

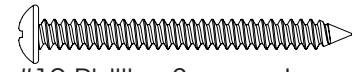

#10 Phillips Screw - Long X 2

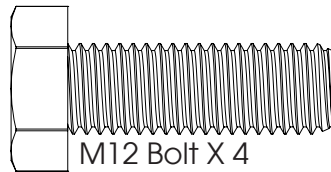

M12 Bolt X 4

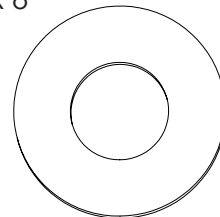

M12 Washer X 8

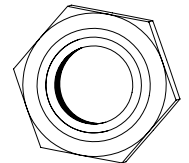

M12 Lock Nut X 4

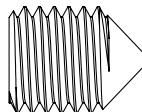

M12 Set Screw X 2



Butt Connector X 4



Black Wire X 1



White Wire X 1



HD Wheel Mount

Important Safety Information

Your Rugged Ridge® Tire Carrier is intended to increase the utility and enjoyment of your Jeep® by providing easy access to your rear cargo area and secure mounting of your off-road spare tire. Before installation, please take a moment to review the following safety information and installation instructions. Important safety information is generally preceded by one of three signal words indicating the relative risk of injury. The signal words mean:

WARNING

A hazardous situation which, if not avoided, could result in serious injury or death. **You can be killed or seriously hurt if you do not follow instructions.**

CAUTION

A hazardous situation which, if not avoided, could result in minor or moderate injury. **You can be moderately hurt and may also suffer property damage if you do not follow instructions.**

NOTICE

Careful attention is required to this instruction or operation, but does not generally relate to personal injury. Damage to your product or other property may result if you do not follow instructions.

Installation Instructions

To reduce risk of personal injury during assembly and use of this product:

- Wear gloves and safety glasses during installation.
- Tire Carrier and spare tire/wheel are heavy. Use jack or seek assistance when lifting, fastening parts, or installing wheel/tire to carrier.
- Tire Carrier is subject to vibration and shock loads from on and off road use. Regularly inspect carrier and lug nuts fastening spare to carrier. Do not use and repair if damaged. Use thread locker and keep lug nuts torqued to 80 ft./lbs.

**Rugged
Ridge**



ALLOY
USA

HD Wheel Mount

NOTICE - If using the **HD Wheel Mount** with the **Rugged Ridge HD Hinge Casting (Part# 11546.51)**, it is necessary to install the **HD Hinge Casting** first. Please stop here and refer to the **11546.51 HD Hinge Casting Instruction sheet**.

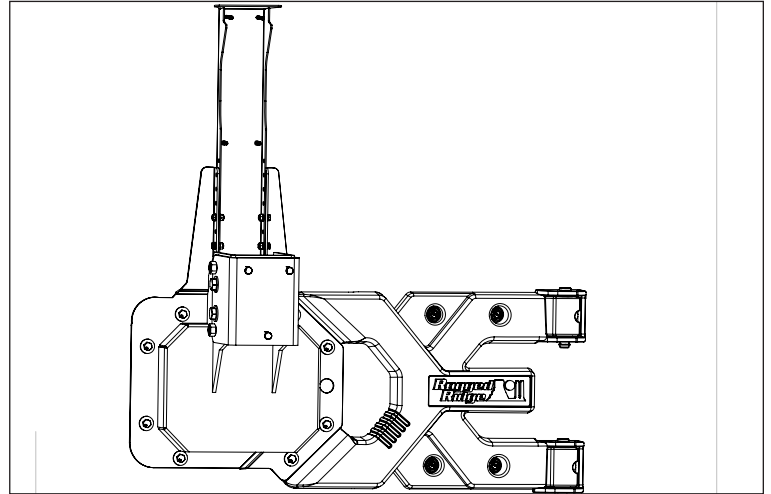

1. Take off the spare tire by removing the 3 lug nuts using a 3/4" deep socket.

CAUTION Have another person help lift the tire off of the carrier.

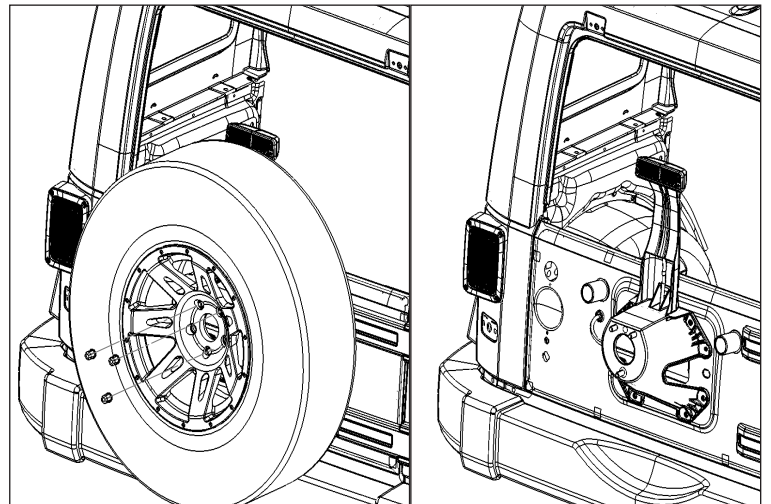

2. Open the tailgate. Using a T-20 Torx bit, remove 4 torx head screws that attach light to factory tire mount. Pull light away from tire mount.

3. Remove connector by pushing down on tab and pulling. Set light aside, it will be used later during installation. Place connector and wires off to side to not interfere with Tire Carrier installation.

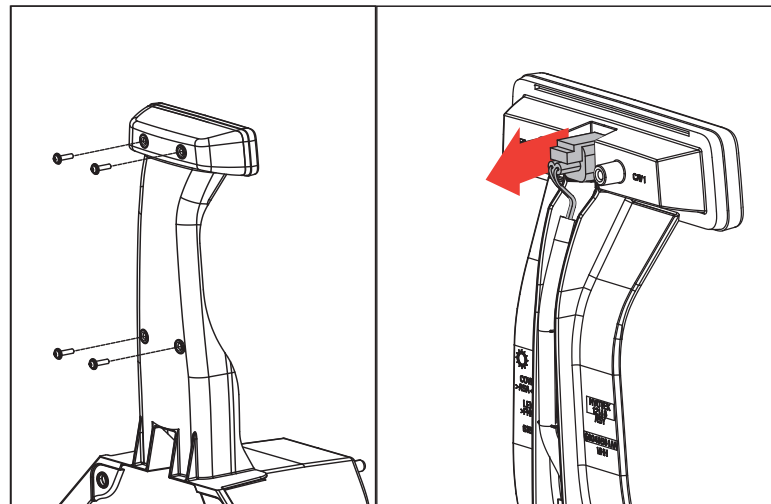



HD Wheel Mount

4. Remove the stock tire carrier and brake light holder by removing the 8 bolts indicated using a 13mm socket.

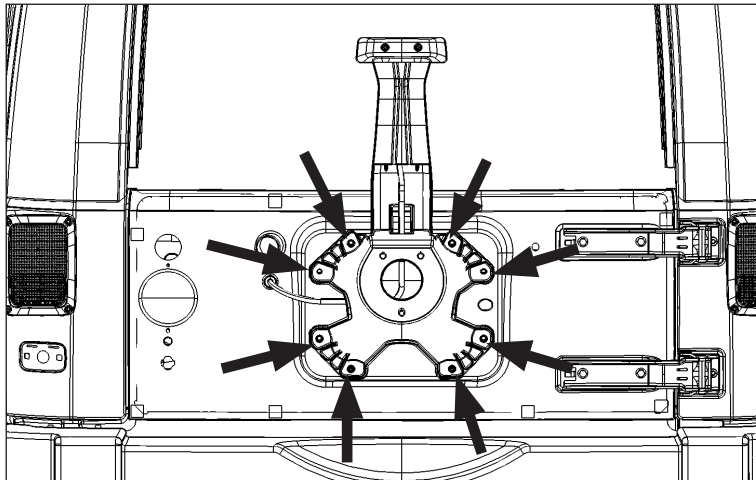

5. Position Wheel Mount Main Plate in place on the tailgate. Use a 13mm socket to loosely thread 4 of the supplied M8 bolts and washers on the left side of the Wheel Mount. Do not fully tighten.

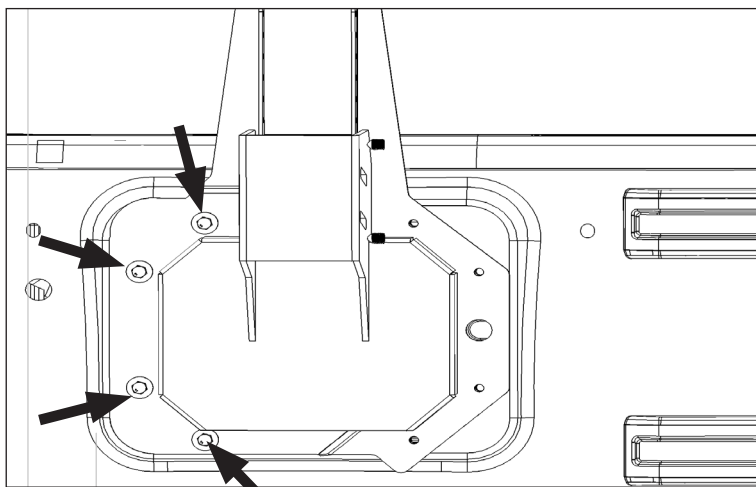

6A. If using the stock tailgate hinges, slide spacer plate between tailgate and top right corner of Wheel Mount. Loosely install M8 bolts and washers with a 13mm socket. Repeat for bottom right corner. Fully tighten all 8 bolts.

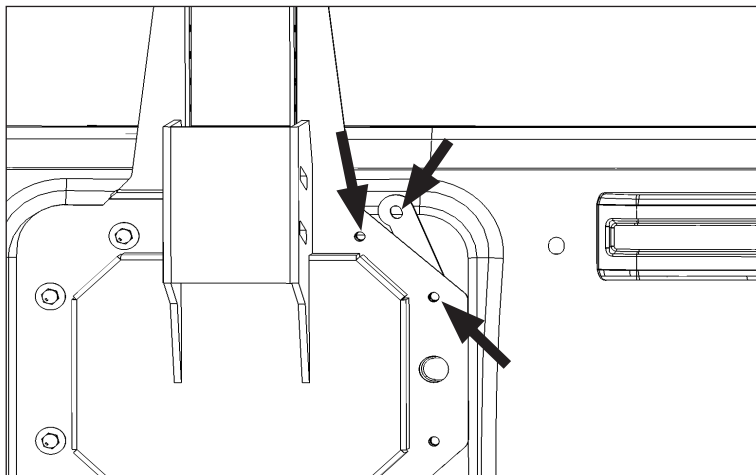



HD Wheel Mount

6B. If using with the HD Hinge Casting (part# 11546.51), no spacers are required. Position Wheel Mount and install and fully tighten all 8 M8 bolts and washers in steps 5 and 6A with a 13mm socket.

Then, with the 13mm socket, install the 4 hex bolts and washers, included with the HD Hinge Casting, at indicated areas to fasten the hinge body to tailgate. Use red thread locker on bolt threads prior to installation, and fully tighten bolts before thread locker dries.

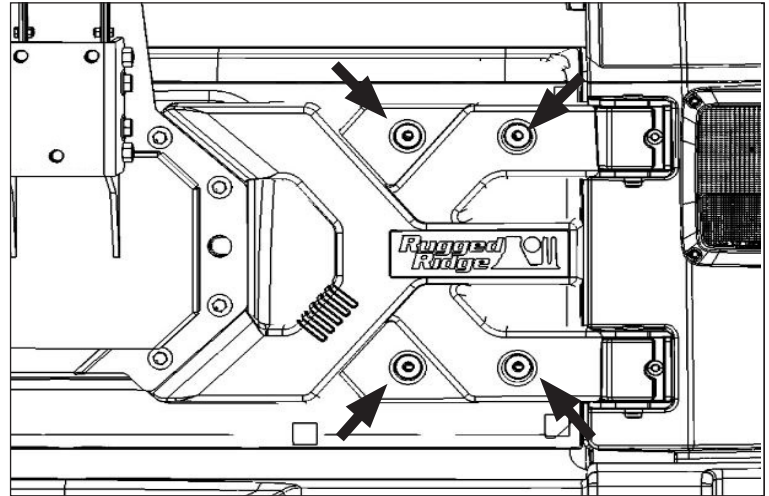

7. Slide Lug Plate onto main carrier plate.

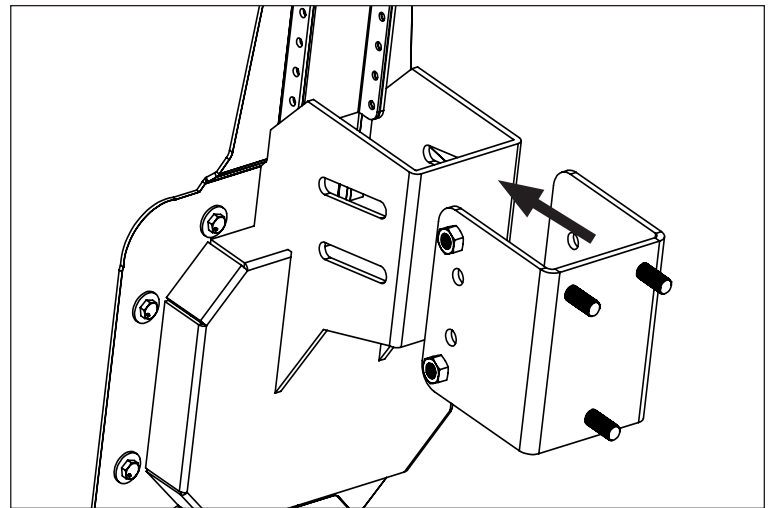

8. Using a 19mm wrench and socket, loosely secure the Lug Plate to the Main Plate with the supplied M12 Hardware. Do not fully tight yet. Bolts should be tight enough to prevent Lug Plate from moving freely, but loose enough to manually adjust its position and orientation.

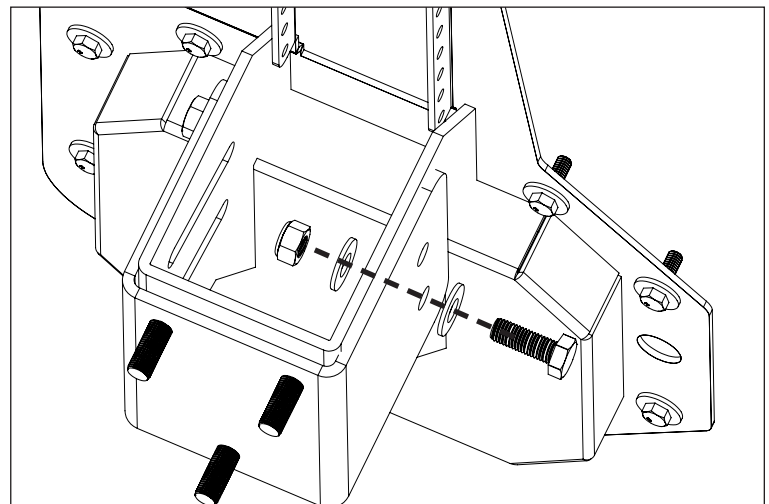

HD Wheel Mount

9. Install spare tire and lug nuts onto Lug Plate. Manually adjust position/angle of the spare tire. Install and tighten 2 set-screws using a 6mm allen wrench to hold Lug Plate in position.

CAUTION Have another person help lift the tire onto the carrier.

WARNING When adjusting wheel position, make sure wheel and tire are as close as possible to the vehicle/Wheel Mount without touching. If mounted too far away from vehicle, it can cause unnecessary stress or damage, which could result serious injury or damage to property.

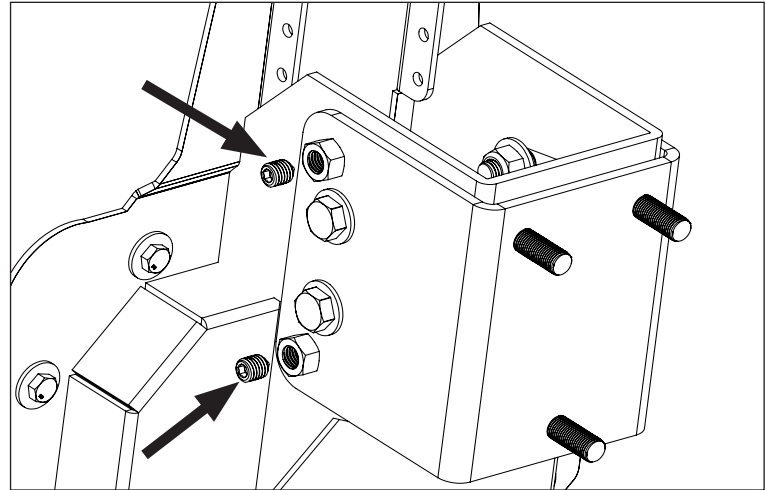

10. Using a 10mm wrench and socket, install Brake Light Extension using supplied M6 bolts, washers, and nylon lock nuts.

CAUTION Your Jeep® high-mounted brake light is mandatory highway safety equipment. Do not delete and ensure light is visible over your choice of spare wheel/tire. Final position of light may need to be adjusted to ensure proper visibility once brake light and spare tire is mounted (see instructions below).

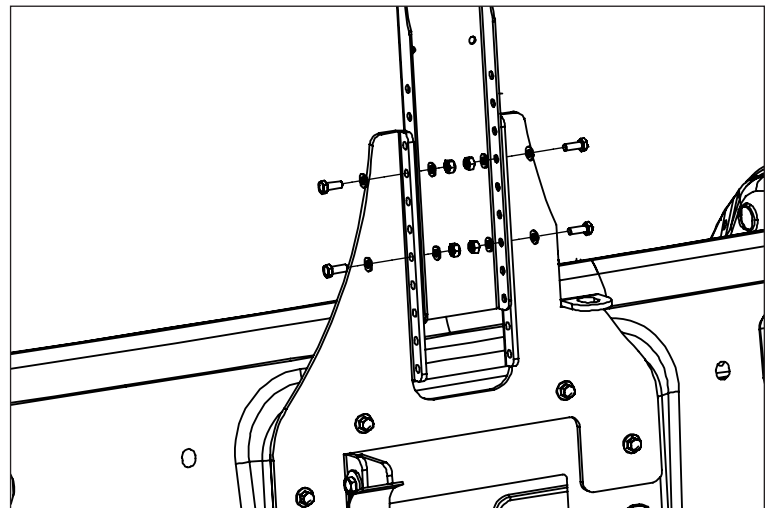

11. Gently remove spare tire, making sure lug plate does not change position. Fully tighten all four M12 bolts/nuts to secure lug plate to Main Plate using a 19mm wrench and socket.

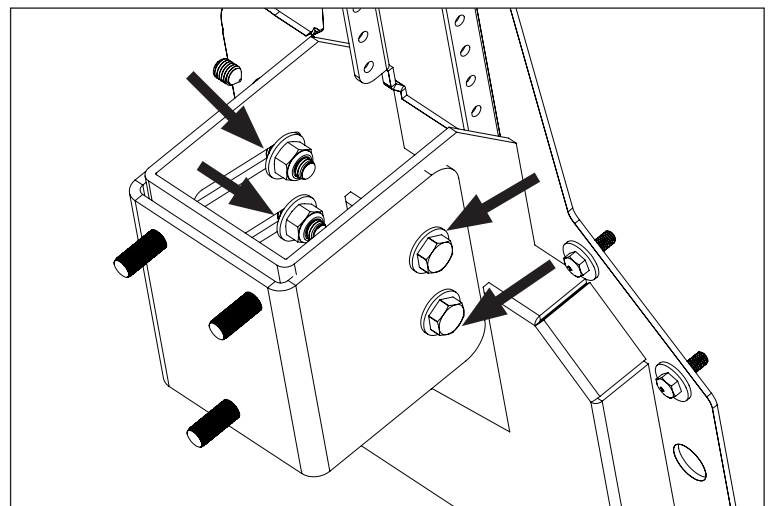

HD Wheel Mount

12. Once Tire Carrier installation is complete, before installation of spare tire, reconnect wires to factory third brake light by pushing connector until it clicks.

13. Install factory third brake light to Brake Light Extension using provided #10 screws and phillips head screwdriver. Long screws are for top two holes. Short screws are for bottom two holes.

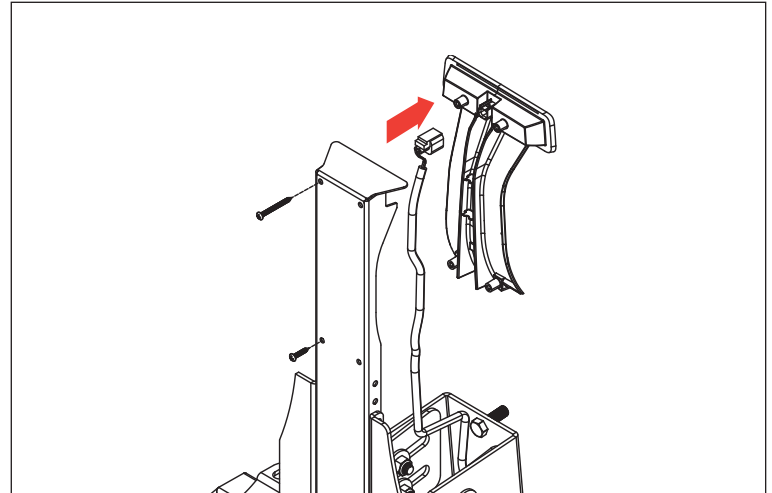

OPTIONAL: For larger spare tires, it may be necessary to raise Brake Light Extension to be seen over spare tire. This may require additional wire to be spliced and added to factory third brake light wires.

14. Open tailgate and remove plastic vent by pulling on left side until clips release.

15. Unplug connector by pushing in tab and pulling down.

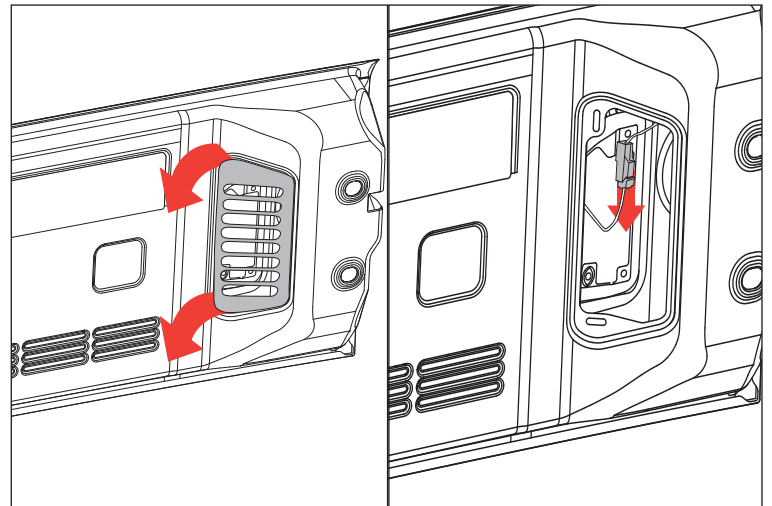

16. Remove rubber grommet in tailgate. Hold grommet tightly in one hand, and pull the wire through the grommet to increase the length of wire that is coming out of the grommet.

17. If the wire is still not long enough, additional wire must be spliced in using the supplied wire and connectors. In the section of wire between uppermost connector and mesh cover, use wire cutters/ crimpers to cut and splice in additional wire length.

18. Reinstall rubber grommet in tailgate. Reconnect wire connector inside tailgate. Reinstall plastic tailgate vent.

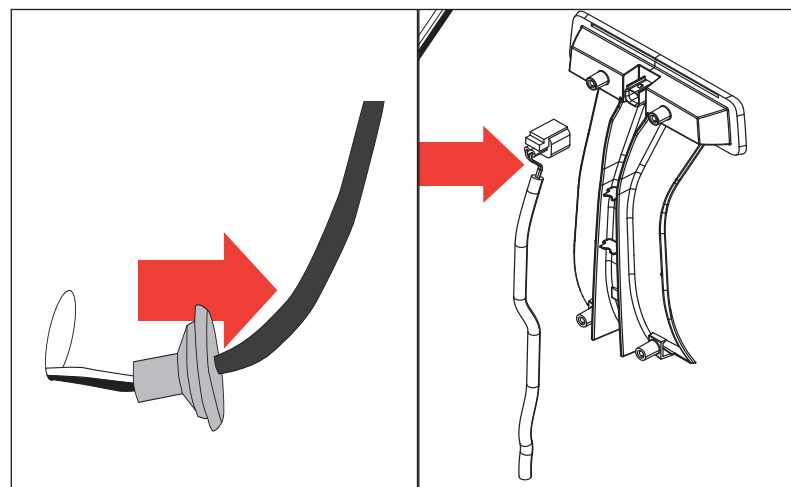



HD Wheel Mount

19. Install spare tire and supplied lug nuts back onto tire carrier. Use a torque wrench with a 3/4" deep socket to tighten the lug nuts to 80 lb/ft.

CAUTION Have another person help lift the tire onto the carrier.

WARNING Failure to tighten the lug nuts to the proper torque specification of 80 lb/ft could result in serious injury or property damage.

