

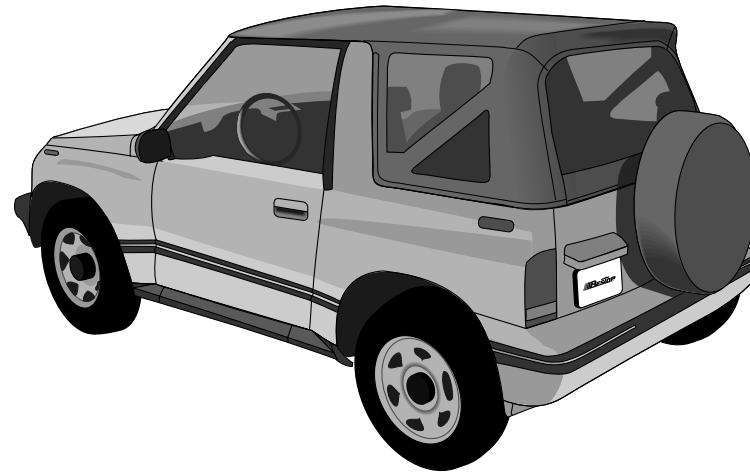

Fabric Replacement Top Installation Instructions

For: GEO Tracker, Suzuki Sidekick
& Vitara 1986 - 1994



Parts List

Top, Soft	(1)
Rear Window	(1)

WARNING

This product is designed to enhance the appearance of the vehicle and to shield the occupants from ordinary weather conditions. Do not rely in any way on the components of this product to contain occupants within the vehicle, or to protect against injury or death in the event of an accident. This top will not protect the occupants from falling objects. Never operate vehicle in excess of manufacturer's specifications.

WEAR SEAT BELTS AT ALL TIMES.

Read and follow, precisely, all installation instructions provided when installing top. Failure to do so may result in a poor fitting top and could place occupants of the vehicle in a potentially dangerous situation. After installing or reinstalling the top, check to make sure it has been properly installed.

Installation Tips

After completing the installation, keep these instructions for future reference. Before you begin installing this top assembly, read all instructions thoroughly. Below are a few tips to make this installation easier.

For a smooth fit:

For ease in installation, the top should be installed at temperatures above 72° F. Below this temperature, the top may contract an inch or more, making it difficult to fit to the vehicle.

It is normal for a top to contract and wrinkle when stored in the shipping carton. Within a few days after the installation, the top will relax and the wrinkles will disappear.

Note: The white fiberglass rod in the original rear curtain should be retained for use in installing this top.

Step Two

With the bow up and the hardware in place, drape the top over the hardware. Hook the five clips on the front of the top into the slots in the windshield header.

Hook clips into slots in windshield header

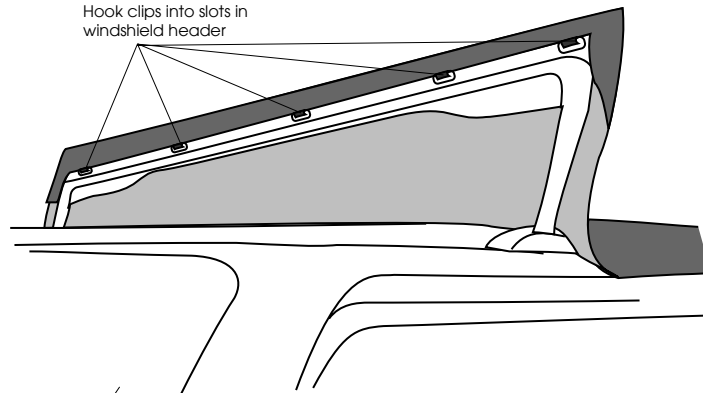

Step One

Unlock the windshield retainer and open it back.

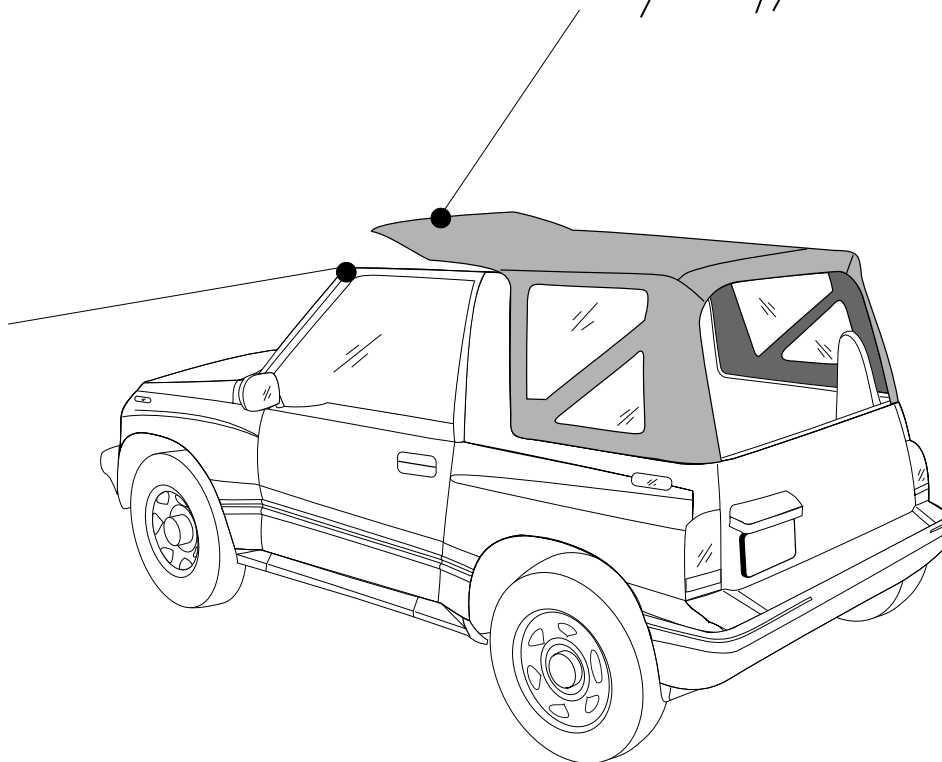
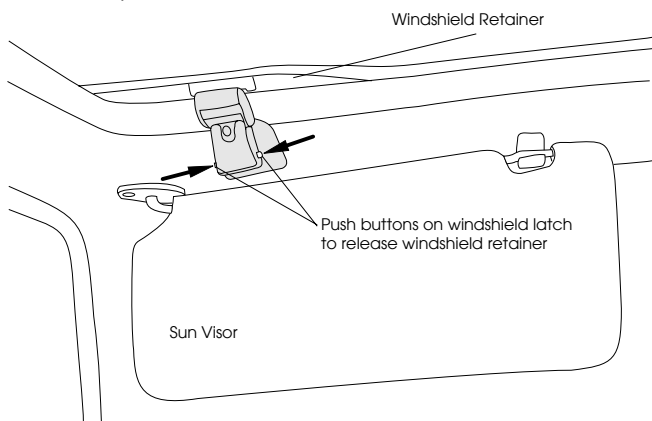

Step Three

Snap the five snaps on the inside of the top to the studs on the rear bow.

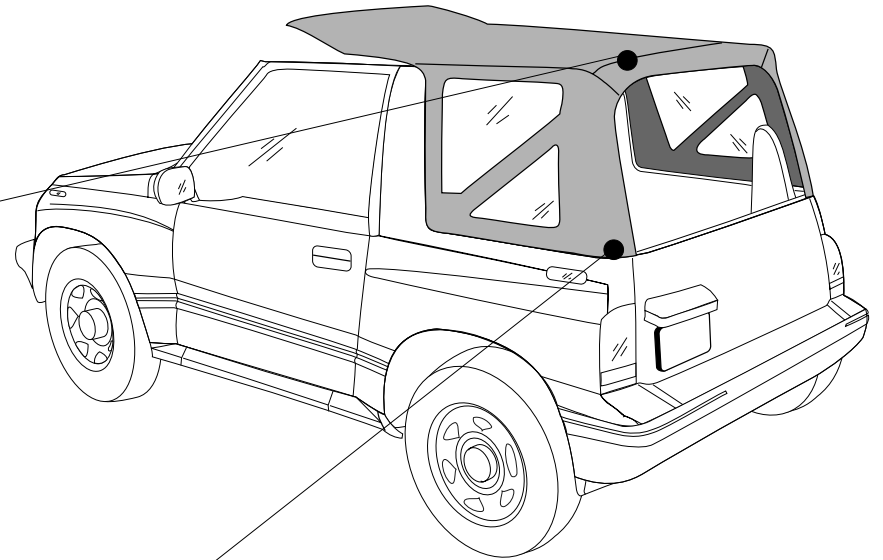
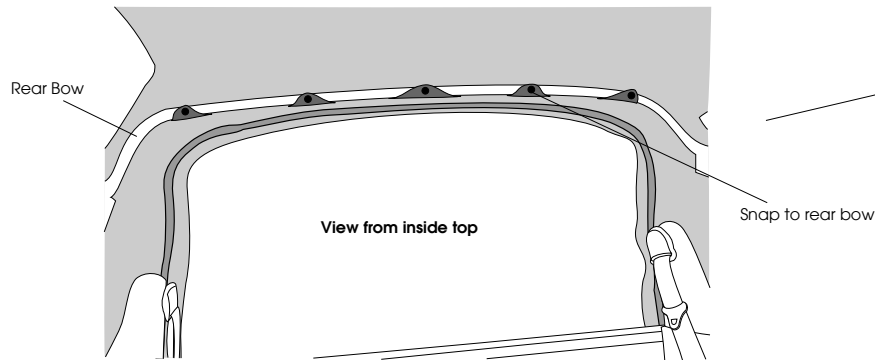

Step Four

Locate the plastic clips sewn into each rear corner of the top. Pull down and back on the top fabric and slip them into the space under the plastic corner retainer attached to the vehicle. The stop on the inside edge of the plastic clip on the top should line up with the inside edge of the retainer.

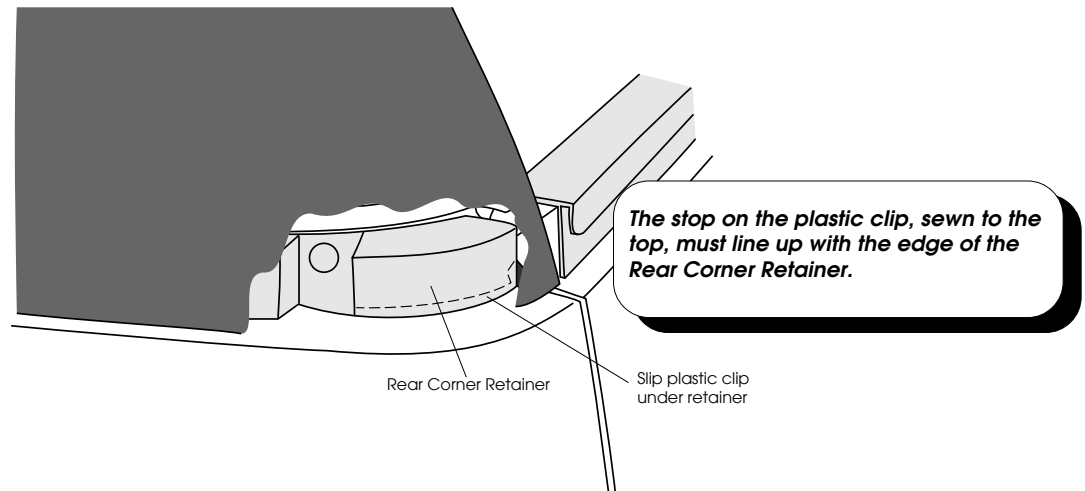

Step Five

Pull the Side Window Retainer away from the vehicle body. Slip the Side Window of the top over the retainer. Separate the hook and loop sewn along the front edge of the Side Window, slide the retainer into place and fasten the hook and loop together around it. Then fit the corner of the retainer into place and fasten the hook and loop sewn along the bottom of the panel around the retainer.

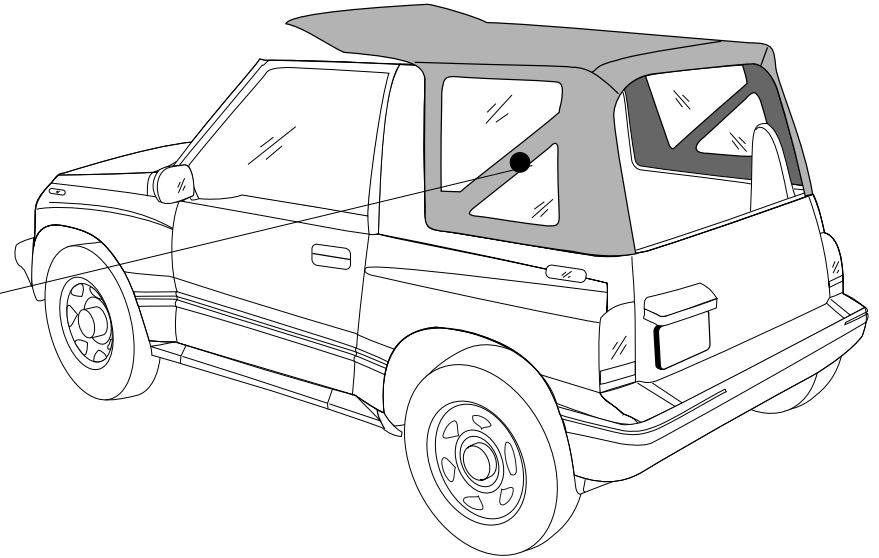
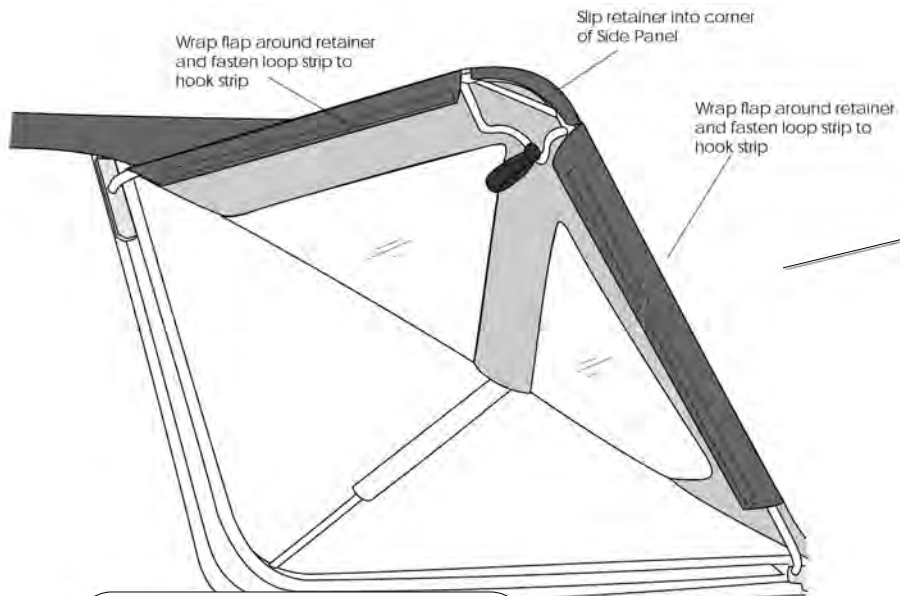

Note: To open Side Window Retainer, pull out and up on the retainer to release it from the clip mounted to the body.

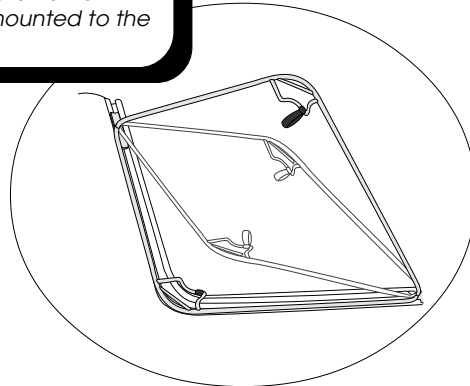

Step Six

Locate the straps, sewn to each side of the top, above the doors. Without twisting the straps, thread them through the loops on the tension assembly. Pull the end of the strap back and snap it to itself.

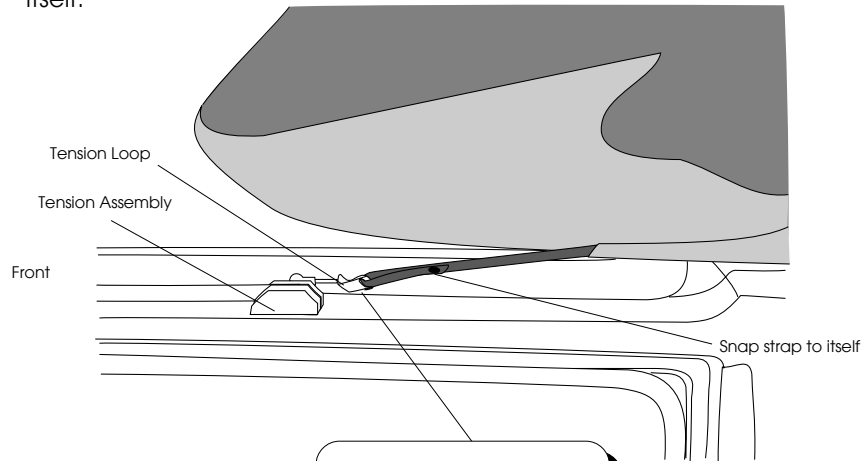

Do not twist strap when threading through loop

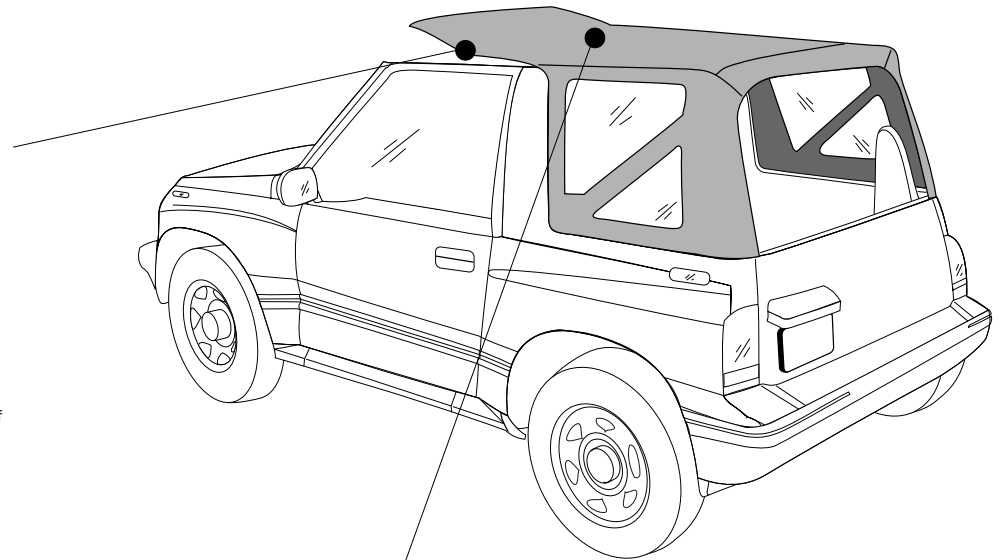

Step Seven

Pull the windshield retainer down and fasten the snaps inside the top to the studs on the center bar.

The hook and loop strap is to hold the windshield retainer securely when the sun roof is open. To use the sun roof, unlock the windshield retainer from the windshield and open it back, folding the fabric top underneath. Locate the small slot in the center of the windshield retainer. Slip the strap through the slot and fasten the hook to the loop sewn to the center flap.

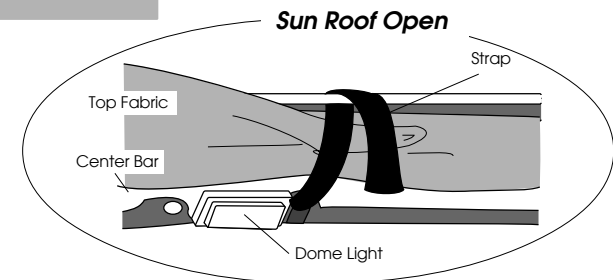
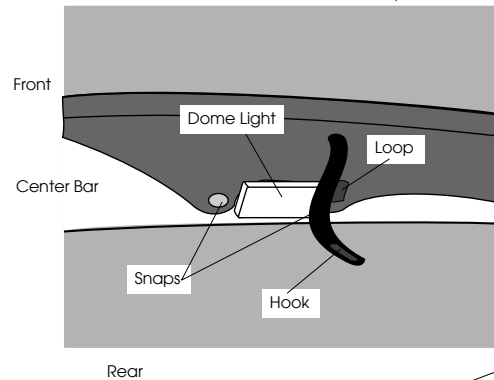

Step Eight

Clip the Side Panel Retainer to the bracket on the vehicle. Wrap the web strap on the retainer around the bow and snap the strap to itself.

View from
inside vehicle

Wrap web strap around
bow and snap to itself

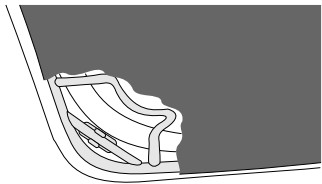

Note: To close Side Panel Retainer, push the retainer into the clip mounted to the body.

Step Ten

Slip the white fiberglass rod from the original top into the sleeve along the bottom of the Rear Window.

Rear Window
Rear Window Retainer Rod - Slide into sleeve

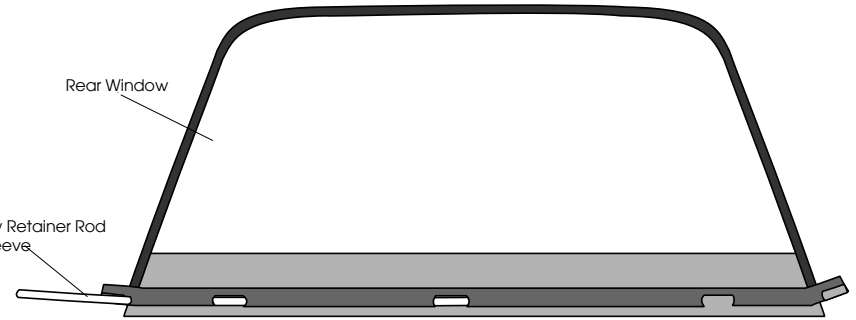

Step Nine

Close and latch the Windshield Retainer securely in place.

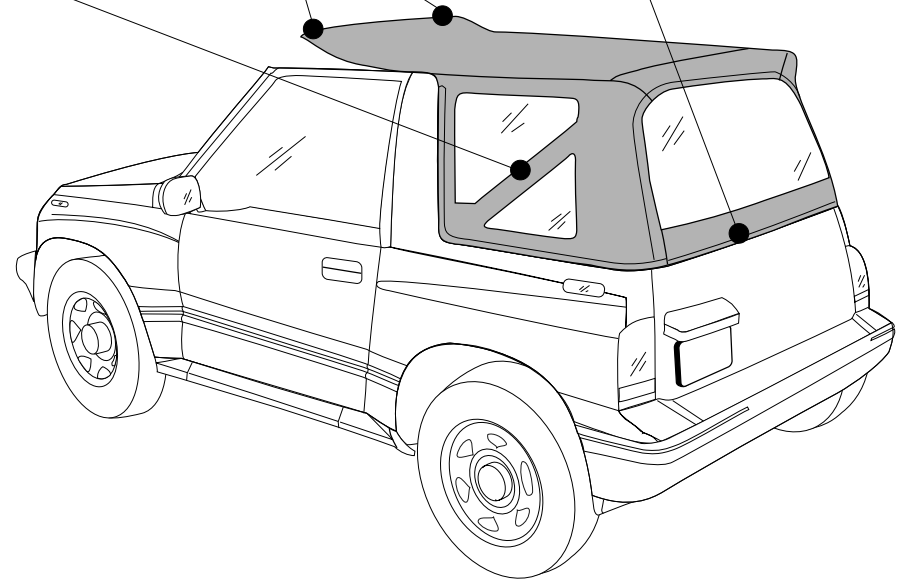

Step Eleven

Starting the zipper on the left hand side, close the zipper on the Rear Window. Tuck the rod sleeve on the Rear Window under the zipper. Pull the hook tab around from inside the rear window, below the zipper, and attach it to the loop sewn to the inside of the side panels.

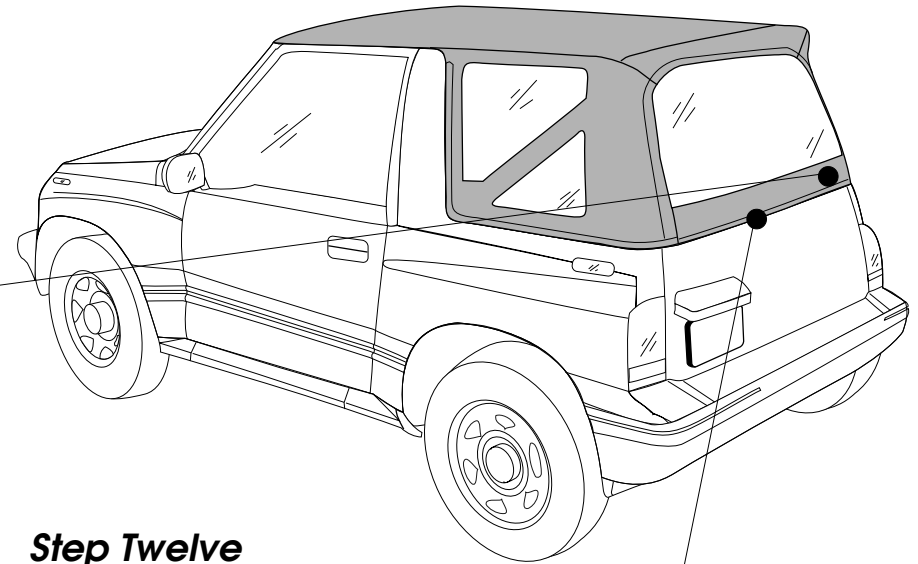
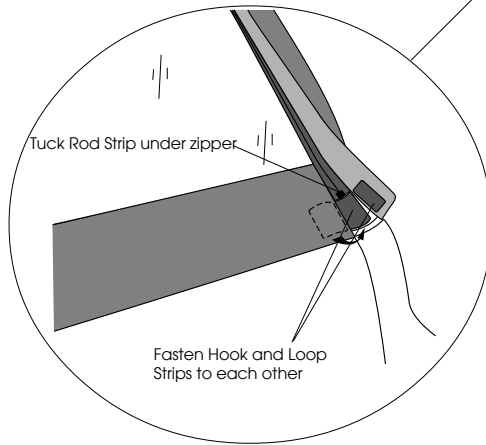
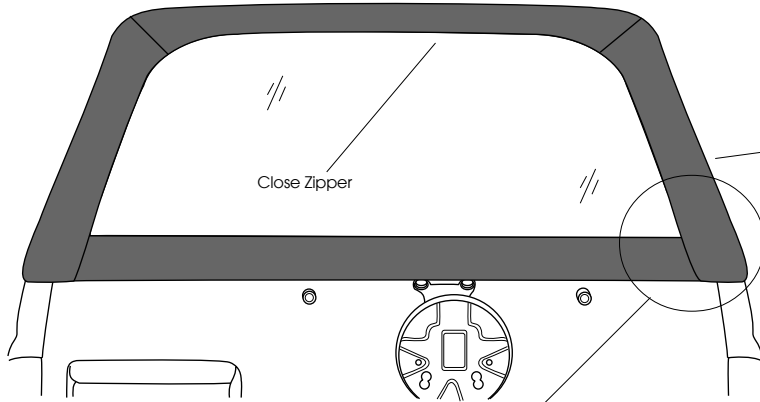

Step Twelve

Hook the Rear Window Retainer Rod into the center bracket on the tailgate and then into the bracket on each side of the tailgate.

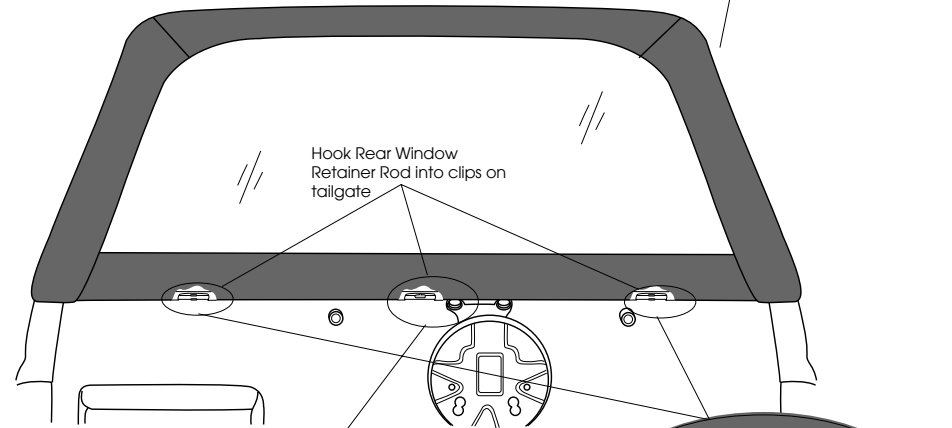

Detail of Rear Window Retainer Rod into center tailgate bracket

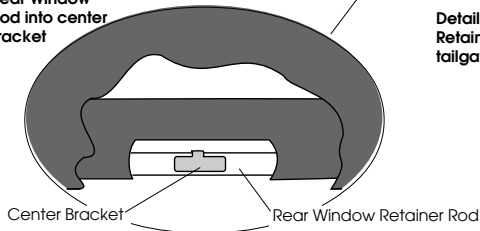

Detail of Rear Window Retainer Rod into side tailgate brackets

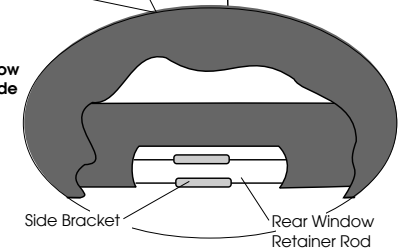

Care and Maintenance of your Top

Your top is made of the finest materials available. To keep it looking new and for the maximum possible wear, it will need periodic cleaning and maintenance.

Washing: The top fabric should be washed often using soap, warm water and a soft bristle brush. Rinse with clear water to remove all traces of soap.

Windows: Keep windows clean to avoid scratching. DO NOT use a brush on the windows! Wash with a watersoaked cloth or sponge and a mild dishwashing detergent. NEVER WIPE THE WINDOWS WHEN THEY ARE DRY. Be careful when cleaning snow or frost from the vinyl windows since they are easily scratched and may crack at low temperatures. DO NOT roll the sides or rear window in cold weather. The windows become stiff and will crack.

Zippers: Keeping the zipper cleaned and lubricated with a silicone lubricant will help prevent damage and keep the zippers in a smooth working condition. If a zipper opens behind the slider, the slider may have been spread apart. This problem can usually be repaired by using an ordinary pair of pliers to bring the sides back into parallel. Return slider to the end of the zipper in the normal Open position.

Squeeze lightly at first and test the zipper. If the zipper continues to remain open squeeze more firmly with the pliers and try the zipper again. Repeat this procedure until the zipper operates correctly.

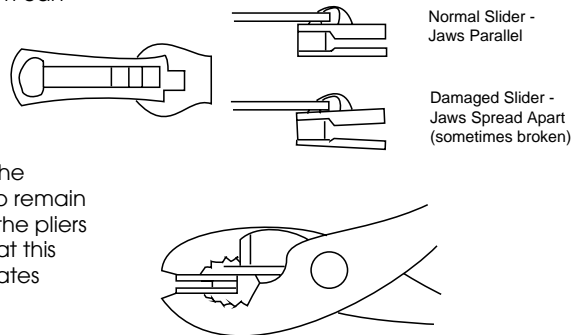

Water: Seeping through at the seams may be stopped by applying 3-M Scotchgard™ on the inside of the seams. Rips in the fabric may be repaired with Bondex™ iron on patches. Iron the patches to the Inside of the top, carefully following the Bondex™ instructions.

Snaps: Keep snaps cleaned and lubricated with silicone to help prevent snaps from sticking to the studs. If a snap does become stuck to a stud, use a screwdriver and GENTLY pry apart to prevent permanent damage to the snap or the top fabric.