



OMIX-ADA, Inc.

Part # 11504.24

## RRC Step Plate, 2 Door JK

### CONTENTS:

- Front Step Plate (2)

### HARDWARE:

- Self-Tapping Screw (12)

### TOOLS REQUIRED:

- Drill
- 9/64" Drill Bit
- Center Punch
- Phillips Head Screwdriver

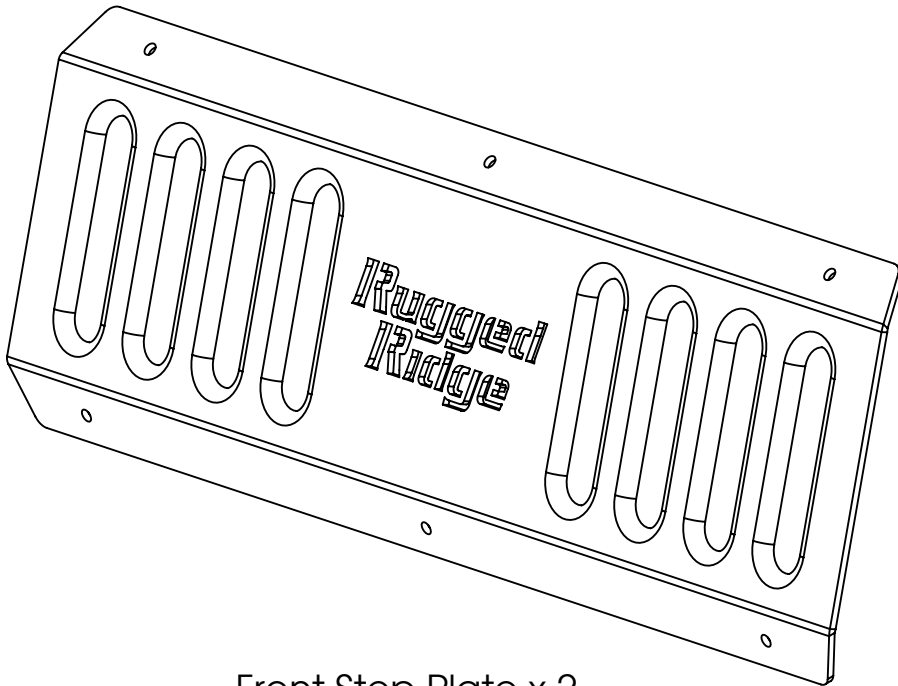

Front Step Plate x 2

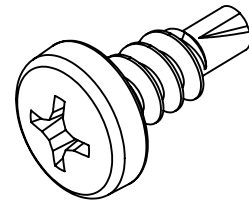

Self-Tapping Screw x 12

### NOTICE

Careful attention is required to this instruction or operation, but does not generally relate to personal injury. Damage to your product or other property may result if you do not follow instructions.



OMIX-ADA, Inc.



## RRC Step Plate, 2 Door JK

1. With RRC Side Armor installed, align Front Step Plates under doors and mark hole locations.

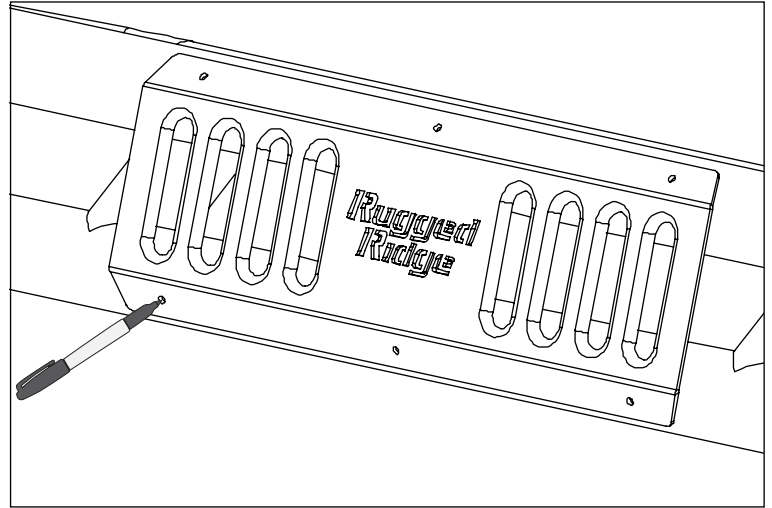

2. Remove Step Plates, uninstall RRC Side Armor, re-mark hole locations with a Center Punch, and drill pilot holes with a 9/64" Drill Bit.

### NOTICE

Use caution when drilling pilot holes to not drill through both sides of tube and to ensure best possible fit of product.

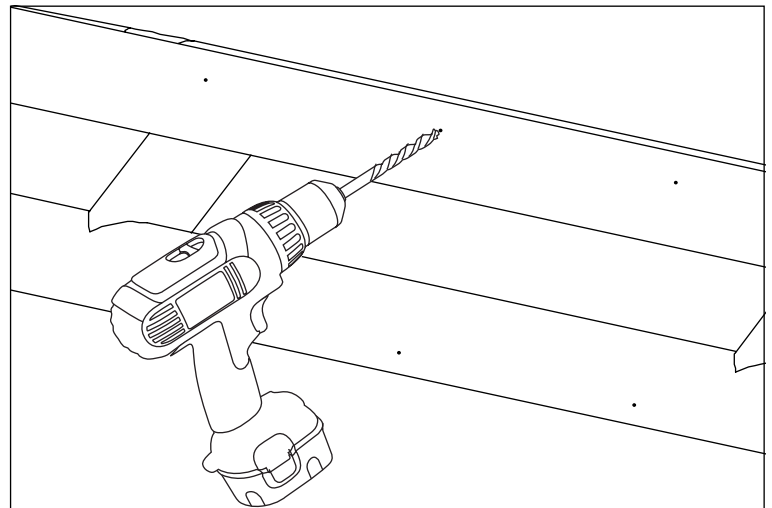

3. Place Step Plates on RRC Side Armor and attach with the supplied Self-Tapping Screws using a Phillips Head Screwdriver. Re-install RRC Side Armor.

