

Rugged  
Ridge



OMIX-ADA, Inc.



JEEP® JK PERFORMANCE VENTED HOOD PATENT PENDING



# JEEP® JK PERFORMANCE VENTED HOOD PATENT PENDING

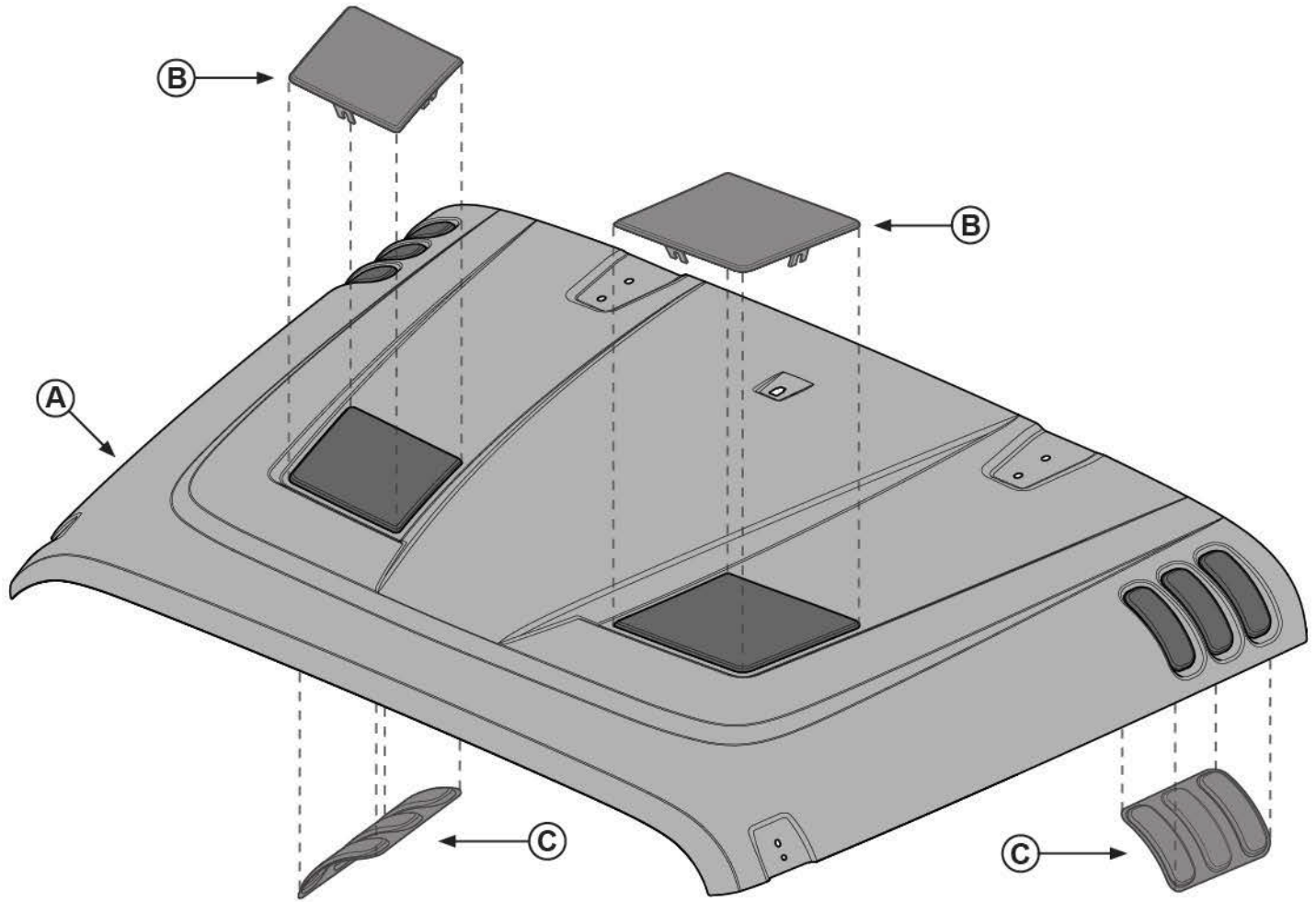

**Contents:**

- **A** - 1 - JK Performance Vented Hood
- **B** - 2 - Top Vents L&R
- **C** - 2 - Side Vents L&R

**Hardware**

- 1 - Tube + Connector
- 2 - Button Head Bolt M6x25
- 6 - Button Head Bolt M6x16
- 8 - J-Clip Fasteners
- 8 - Button Head Bolts M6x10

**NOTICE** Carefully read and understand all instructions before proceeding.

# JEEP® JK PERFORMANCE VENTED HOOD PATENT PENDING

1. Before any priming or painting, remove the four bolts securing the side vents on each side of the hood. Remove side vents from the hood.

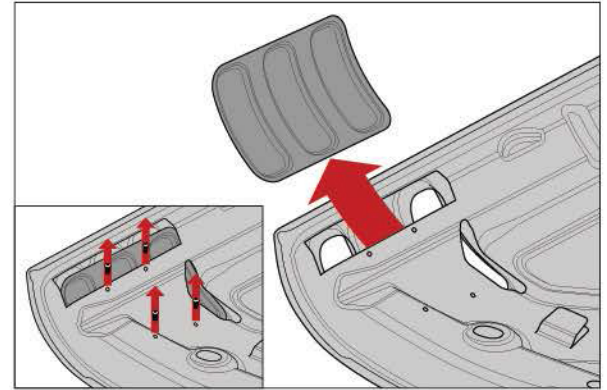

2. Remove top vents from the hood by removing screws. Remove J-clips

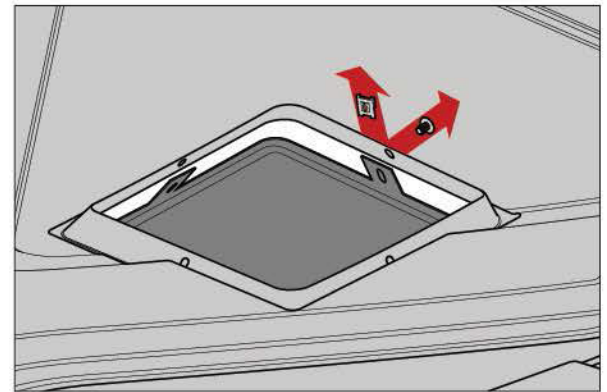

3. Once top vents are removed, bend/pull tabs on vents to create better fitment against hood.

**NOTICE** This step will help ensure less likelihood of damage to paint of hood.

The hood is now ready for priming and painting.

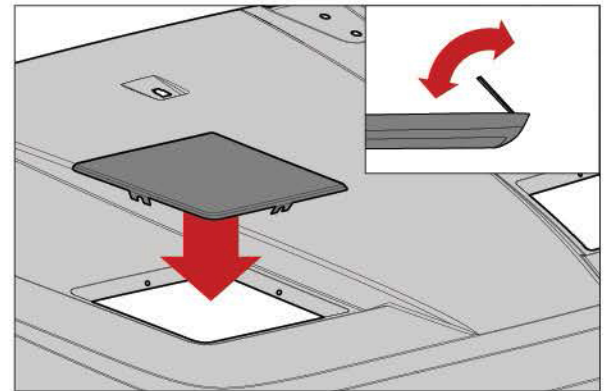

4. Remove ground wire attaching rear of factory hood to vehicle body. Not Applicable for all model years.

**NOTICE** 2007-2012 JK owners skip to Step 6.

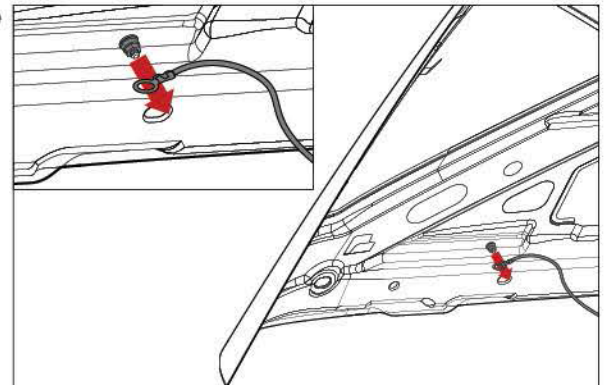



# JEEP® JK PERFORMANCE VENTED HOOD PATENT PENDING

5. Separate washer fluid tube from spliced tubes connected to the nozzles.

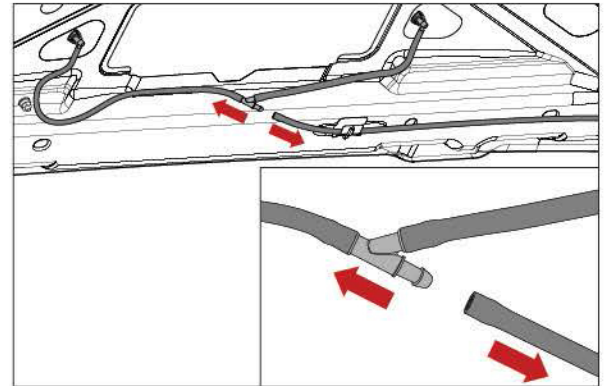

6. Remove washer fluid tube from nozzle(s) found on underside of factory hood. 2013+ JK owners discard spliced tubing.

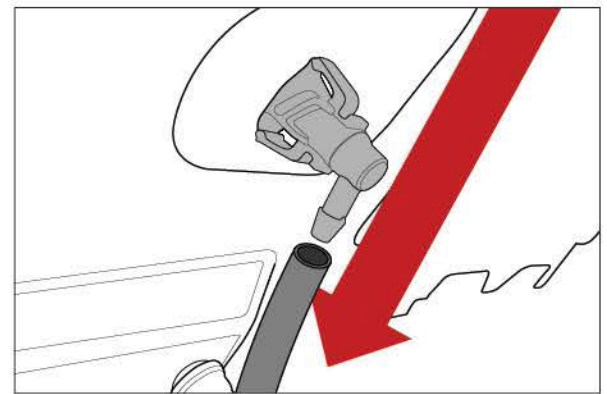

7. Compress and push washer fluid nozzle(s) outward to remove.

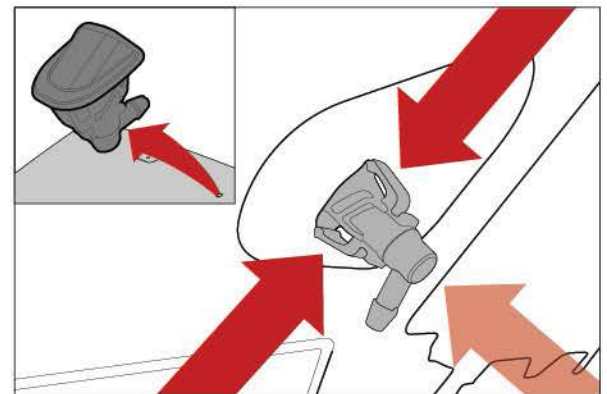

8. Remove the hood catch attached to factory hood.

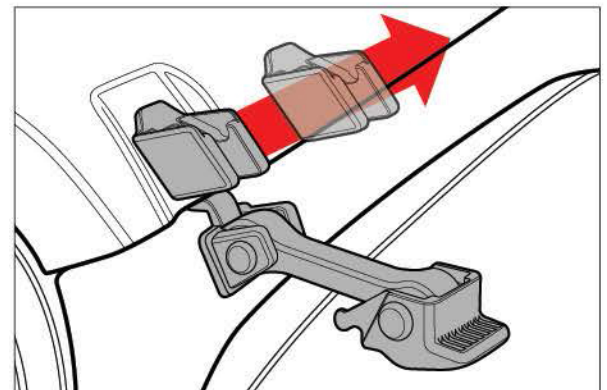

# JEEP® JK PERFORMANCE VENTED HOOD PATENT PENDING

9. Remove torx bolts attaching factory hood to hinges of the vehicle body. Remove factory hood.

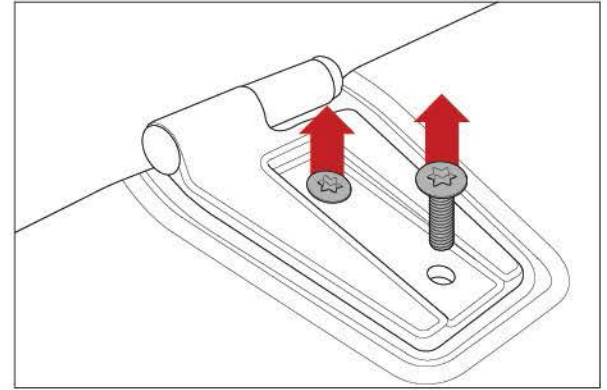

10. Once your hood is painted the color of your choice, slide your side vents back into place. Fasten side vents with bolts removed in Step 1.

**NOTICE** Blue arrow indicates location for M6x25 Button Head Bolt.

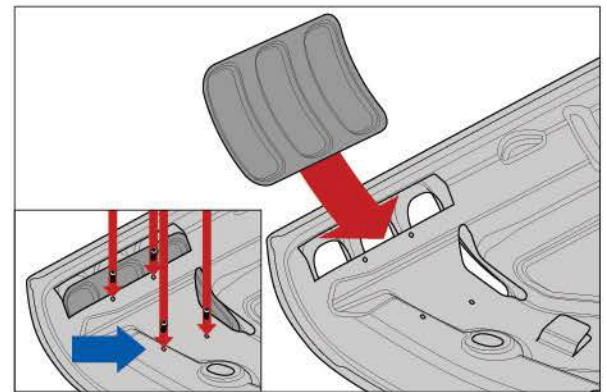

11. Attach & fasten top vents removed in Step 2.

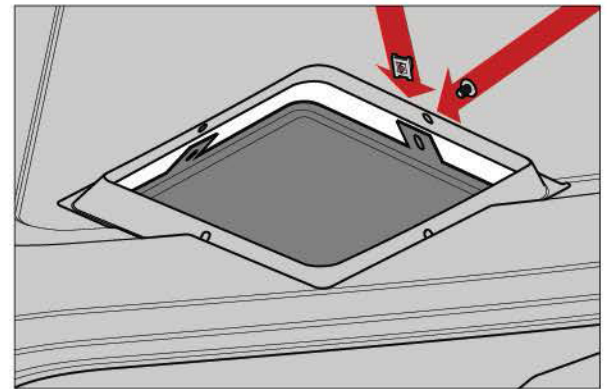

12. Attach your new JK Performance Vented Hood. Fasten hood with torx head bolts removed in Step 9.

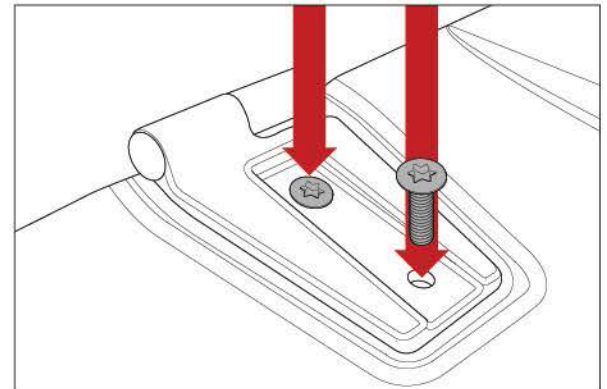

# JEEP® JK PERFORMANCE VENTED HOOD PATENT PENDING

13. Attach washer fluid nozzle to JK Performance Vented Hood. Make sure nozzle faces rear of vehicle.

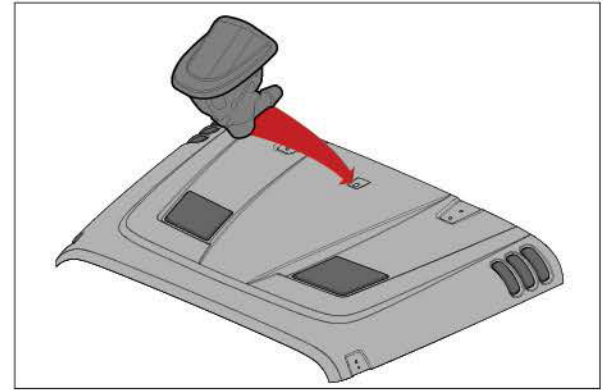

14. Attach supplied tube and connector to your vehicles washer fluid tube.

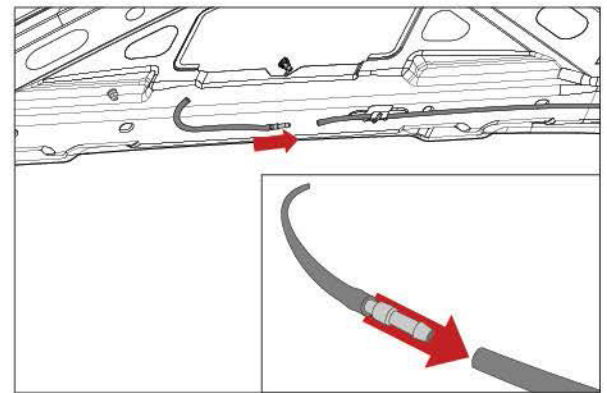

15. Attach supplied tube to washer fluid nozzle on your hood. Cut excess tubing if necessary.

**CAUTION** Cutting/Sharp Edge Hazard: Cut carefully using gloves and eye protection.

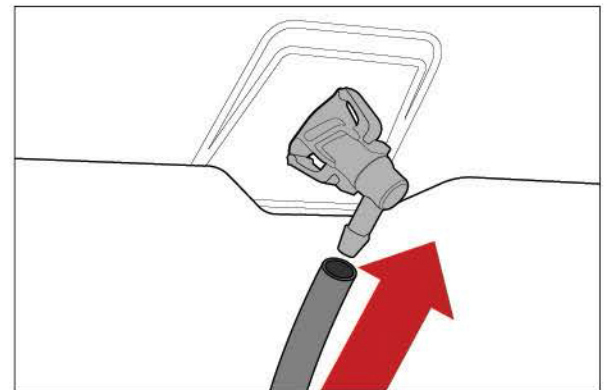

16. Attach ground wire to hood. Not applicable for all model years.

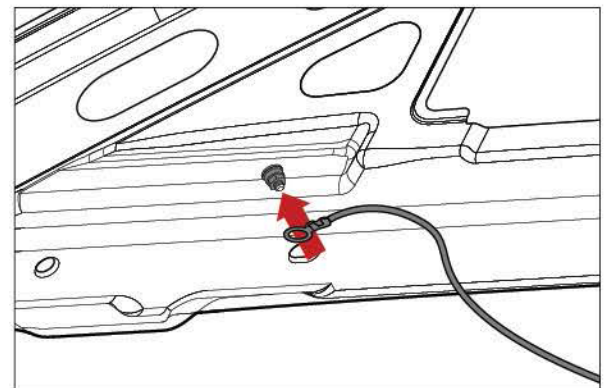



## JEEP® JK PERFORMANCE VENTED HOOD PATENT PENDING

17. Attach the hood catch removed in Step 8 to the hood.

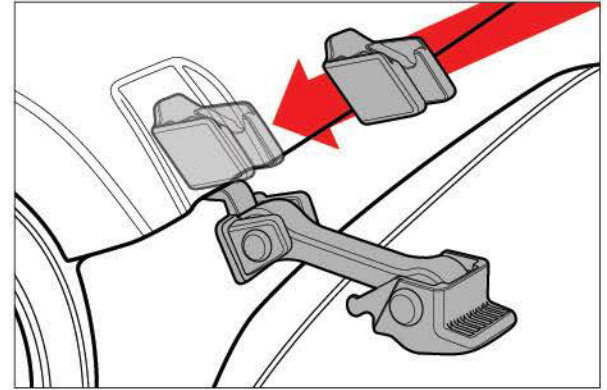

18. If you choose to re-attach the sound damping cover attached to your factory hood, we recommend you to cut out sections to improve heat reduction. Use the JK Performance Vented Hood as a template and trace cut-outs around all vents with a marker. Use scissors or a razor blade to cut areas traced. Securely attach sound damping cover to your Hood. Not applicable for all model years.

**CAUTION** Cutting/Sharp Edge Hazard: Cut carefully using gloves and eye protection.

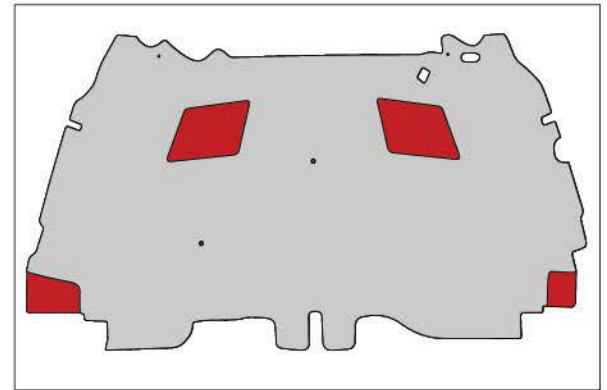

19. Your JK Performance Vented Hood is now attached, enjoy!



# PERFORMANCE HOOD VENTS

## CONTENTS:

- Left Side Hood Vent (1)
- Right Side Hood Vent (1)
- Mounting Bracket, Inner (2)
- Mounting Bracket, Outer (2)
- OE Hood Template (1)

## HARDWARE:

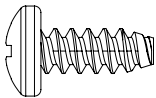

Phillips Screw X 8

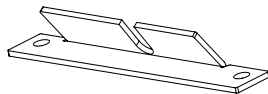
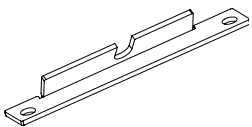

Mounting Bracket, Inner X 2      Mounting Bracket, Outer X 2

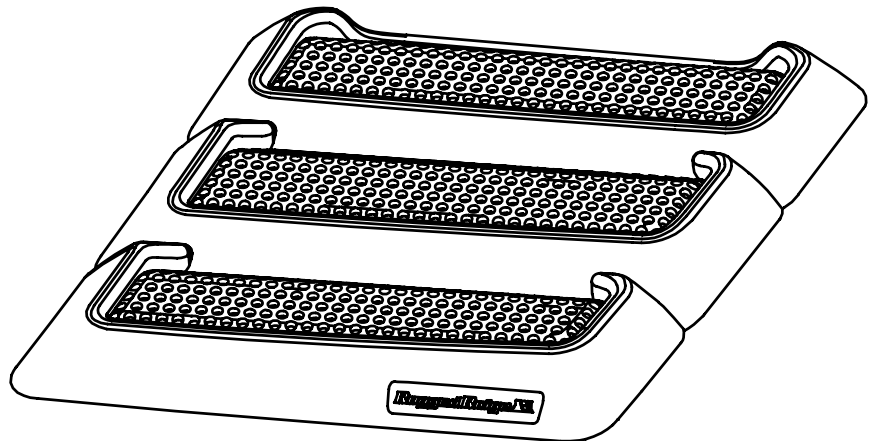
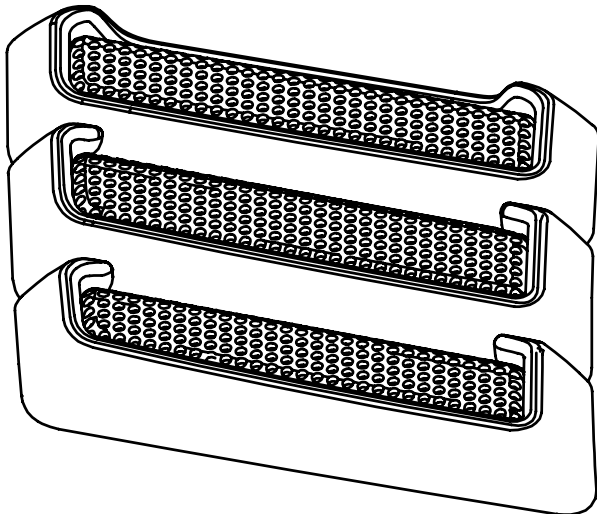

## TOOLS REQUIRED:

### For use with 17759.01 Rugged Ridge Performance Vented Hood:

- Phillips Head Screwdriver
- 3/32 inch Allen Wrench

### For use with OE Hood:

- Phillips Head Screwdriver
- Drill, 1/16" Drill bit, 3/16" Drill Bit
- Angle Grinder/Metal Nibblers
- Center Punch
- Razor or Hobby Knife
- Deburring tool or hand file
- Touch-Up Paint
- Painters Tape
- Marker
- Tree Fastener Removal Tool
- Socket Wrench, 9mm Socket





## PERFORMANCE HOOD VENTS

### Important Safety Information

Your Rugged Ridge® Performance Vented Hood Inserts are intended to increase the utility and enjoyment of your Jeep® by reducing under-hood temperatures and enhancing the look of your vehicle. Before installation, please take a moment to review the following safety information and installation instructions. Important safety information is generally preceded by one of three signal words indicating the relative risk of injury. The signal words mean:

#### **WARNING**

A hazardous situation which, if not avoided, could result in serious injury or death. **You can be killed or seriously hurt if you do not follow instructions.**

#### **CAUTION**

A hazardous situation which, if not avoided, could result in minor or moderate injury. **You can be moderately hurt and may also suffer property damage if you do not follow instructions.**

#### **NOTICE**

Careful attention is required to this instruction or operation, but does not generally relate to personal injury. Damage to your product or other property may result if you do not follow instructions.

### Installation Instructions

To reduce risk of personal injury during assembly and use of this product:

- Wear safety glasses during entire installation.
- Follow manufacturer's safety guidelines for all power tools.
- When using an angle grinder or metal nibblers, make sure to wear gloves, eye, and ear protection, and dust mask. Do not wear loose fitting clothing or jewelry.
- Read entire installation procedure before beginning.

## PERFORMANCE HOOD VENTS

### INSTALLATION INSTRUCTIONS FOR USE WITH RUGGED RIDGE PERFORMANCE VENTED HOOD (part # 17759.01)

**NOTICE** If installing on OE hood, skip to OE Hood Installation Instructions section beginning on page 5.

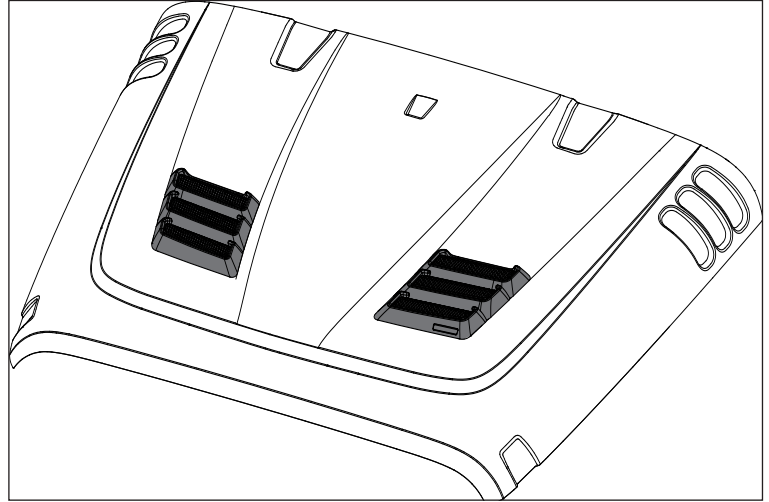

1. Using a phillips head screwdriver and supplied phillips head screws, install inner and outer Hood Vent Mounting Brackets onto each Performance Hood Vent.

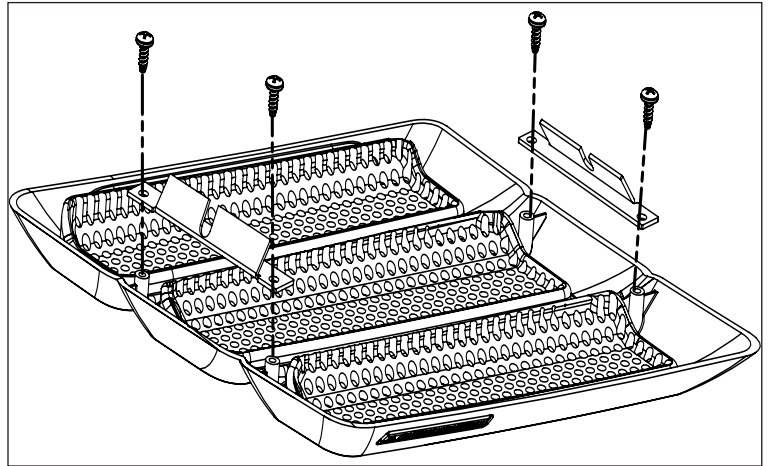

2. Open Hood. Uninstall left and right metal hood vents by removing the 8 J-Clip Screws and J-clips (4 per side) using a 3/32 inch allen wrench.

**NOTICE** Save J-Clips and screws for later use.

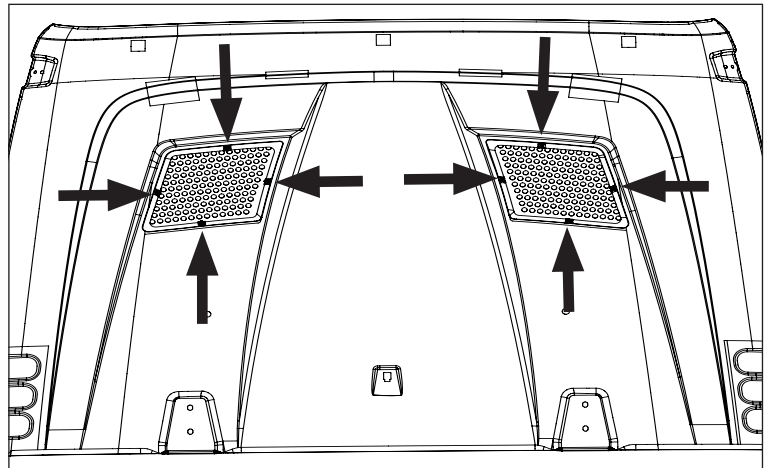

## PERFORMANCE HOOD VENTS

3. Position Performance Hood Vent Insert on top side of hood. Hold vent in place with one hand, and install 2 J-clips, one onto each Hood Vent Mounting Bracket on the user-side of hood. Make sure each J-Clip captures hood flange and Hood Vent Mounting Bracket.

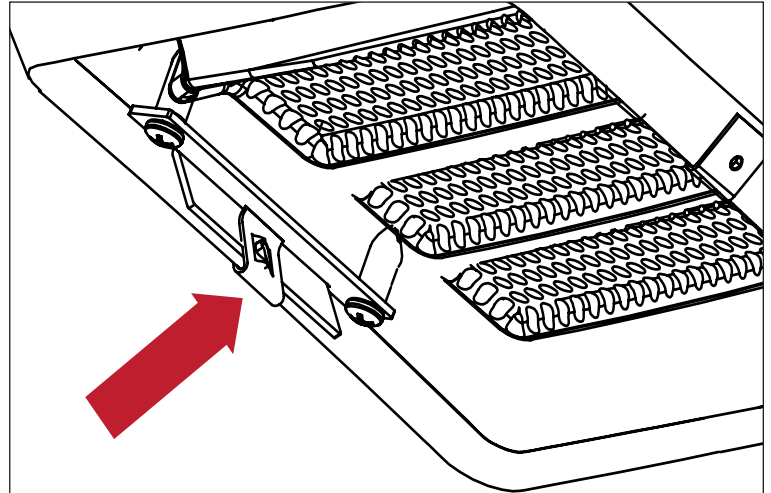

4. With a 3/32" allen wrench, re-install J-Clip screws into the 2 J-Clips and fully tighten.

Repeat steps 3 and 4 for Performance Hood Vent Insert on other side.

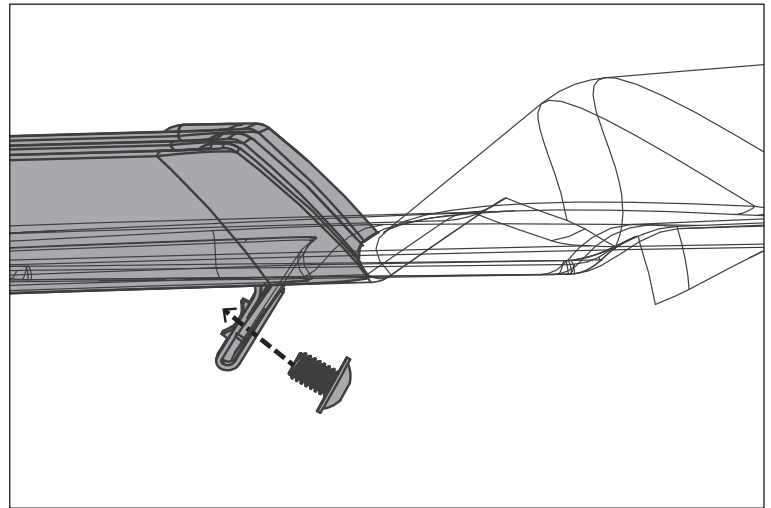



# PERFORMANCE HOOD VENTS

## INSTALLATION INSTRUCTIONS FOR USE WITH OE HOOD.

1. Raise Hood and remove hood insulation blanket by removing christmas tree fasteners using tree fastener removal tool. (JK Model Only)
2. Remove Footman using a 9mm socket. For TJ/LJ models, also remove windsheild bumpers.

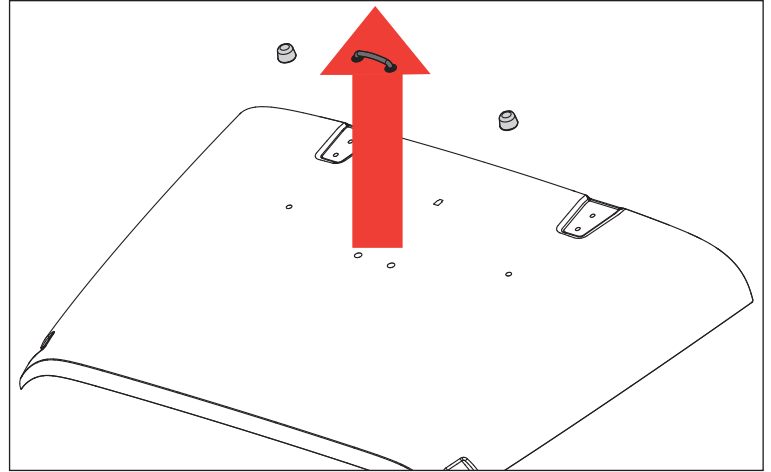

3. Place hood template on flat surface. With a hobby knife or razor blade, cut out the shaded circles for the 'Footman Holes'.

### NOTICE

There are 2 template patterns printed on the template sheet. Make sure to reference only the pattern meant for your vehicle.  
 Items marked **JK** are for 2007-2015 Wrangler.  
 Items marked **TJ/LJ** are for 1997-2006 Wrangler.

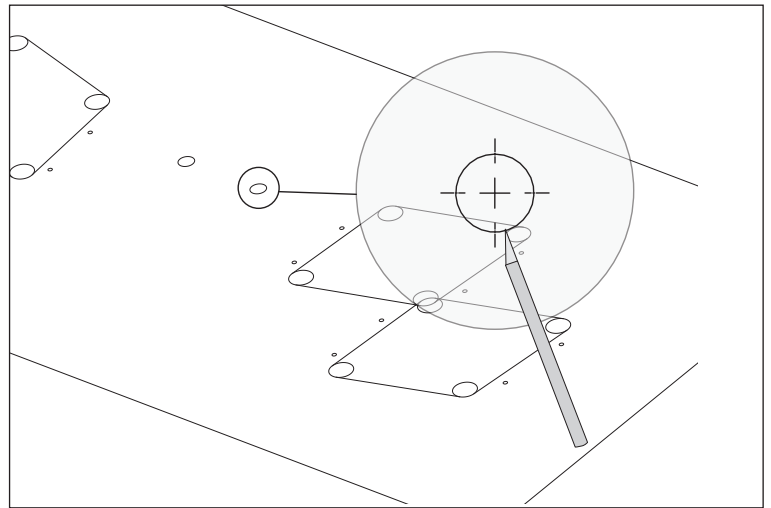

- CAUTION** 4. Lift hood and place a blanket or other protective barrier over **engine bay, fenders, and windshield**. Gently lower hood.

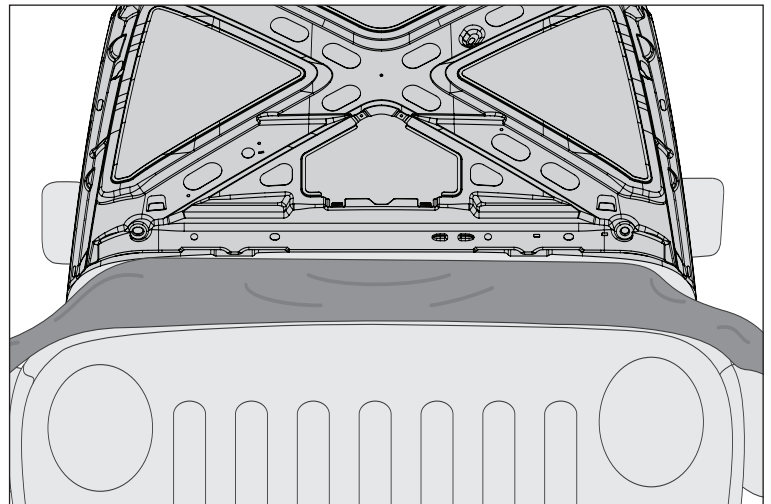

## PERFORMANCE HOOD VENTS

5. Place template on hood and align footman holes from step 4 with corresponding holes on vehicle hood.

6. Reinstall footman (and bumpers, if applicable) to positively locate template on hood.

7. Carefully inspect template placement to ensure proper alignment. Secure template in place with painters tape along edges of hood template.

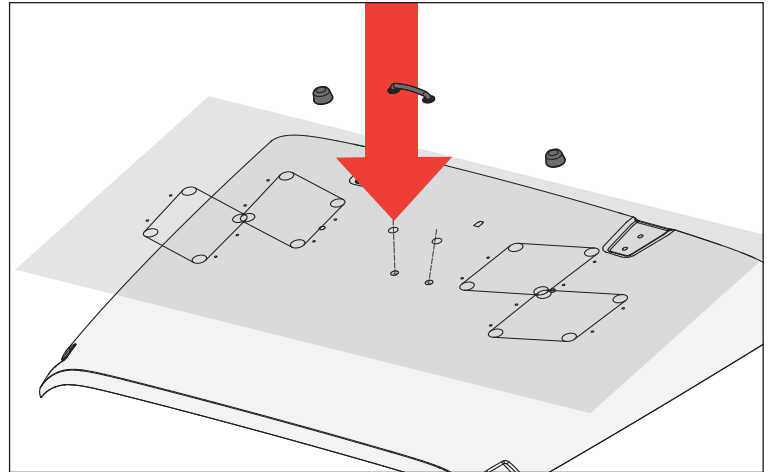

8. Use a center punch to mark the centers of mounting fastener holes for Hood Vents. There are 8 total centers to marks; 4 per side.

**NOTICE** Make sure to use the correct template markings for your vehicle model/year.

9. Using a 1/16" drill bit, drill pilot holes at 8 center punched locations for Hood Vents fastener holes.

10. Use a 3/16" drill bit to enlarge 8 holes for fasteners.

**NOTICE** When drilling holes in hood, be sure to support under-side of hood so the metal does not deform.

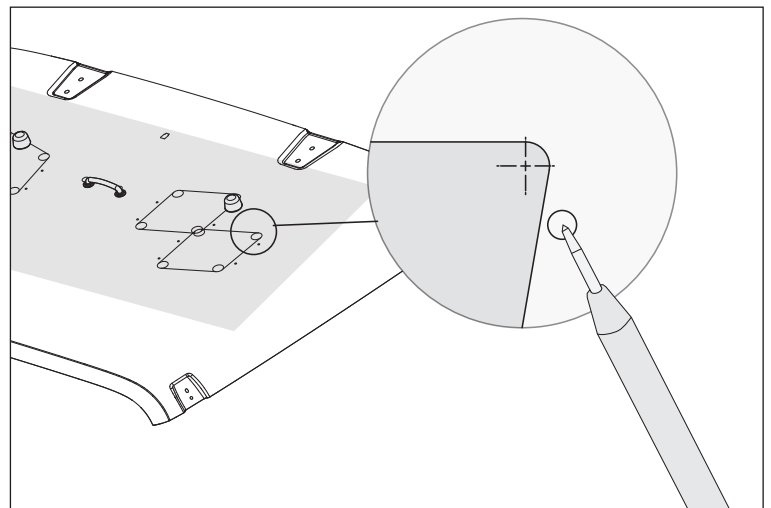

11. OPTIONAL - Use center punch to mark 4 locations on each side of hood where vent holes will be cut under Hood Vents.

12. OPTIONAL - Drill 1/16" pilot holes at 8 locations marked for vent cutouts. Use a 1" sheet metal hole saw to enlarge these holes.

**NOTICE** Make sure to use the correct template markings for your vehicle model/year.

**NOTICE** When drilling holes in hood, be sure to support under-side of hood so the metal does not deform.

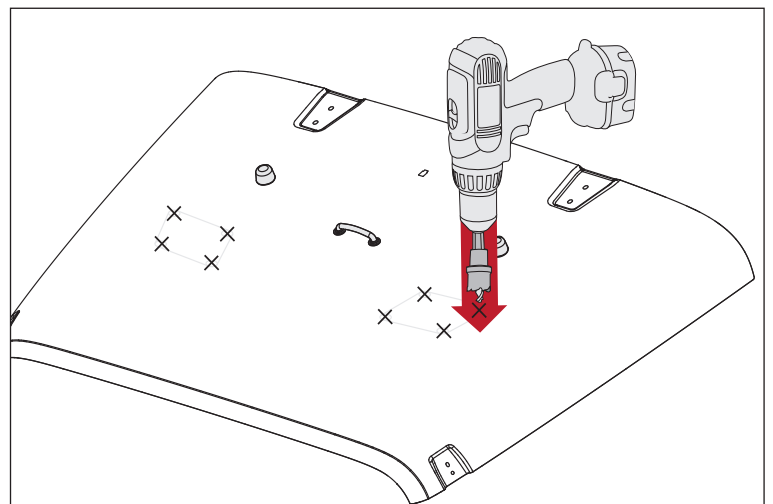

## PERFORMANCE HOOD VENTS

13. Remove hood template and painters tape.

14. OPTIONAL - Use painter's tape to connect each 1" hole with a straight line of tape around outside edges of each hole as shown in template.

15. OPTIONAL - Carefully use an angle grinder with a metal cut off wheel or metal nibbler to cut top layer of hood sheet metal along inside edge of painter's tape.

**⚠ WARNING** Always wear gloves, safety glasses, ear protection, and dust mask when cutting metal.

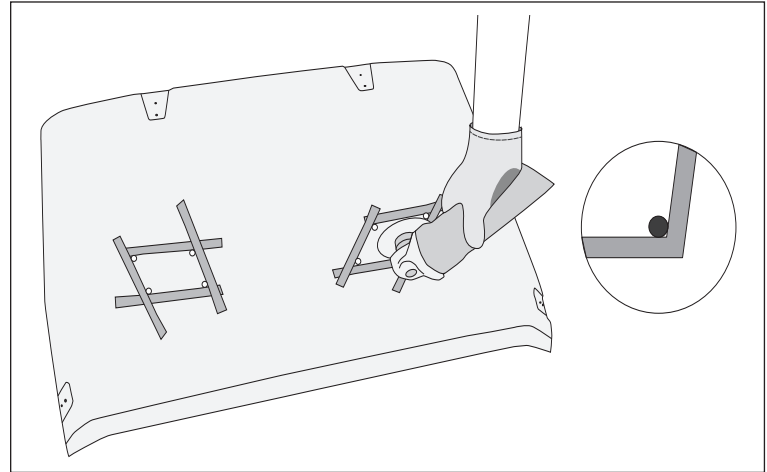

16. Remove painters tape. Use a deburring tool or hand file to remove any burrs or sharp edges created in steps 10-16.

17. Use touch-up paint to cover any exposed metal resulting from cutting and drilling. Allow paint to dry before proceeding.

**⚠ WARNING** Always wear gloves, safety glasses, ear protection, and dust mask when cutting metal.

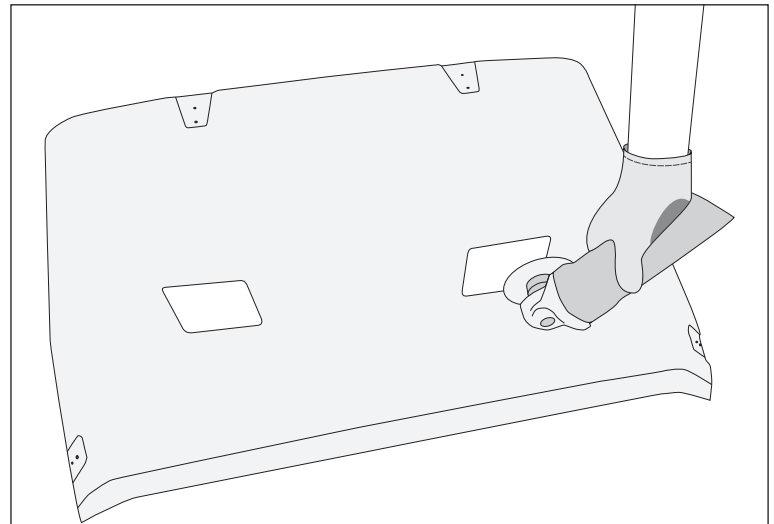

18. For JK models, replace hood insulation blanket. **If optional hole cutouts from steps 12-16 were made:** do not re-install christmas tree fasteners yet. Use a marker to trace hole cutouts onto hood insulation blanket. Use scissors or razor to cut corresponding holes in hood insulation blanket.

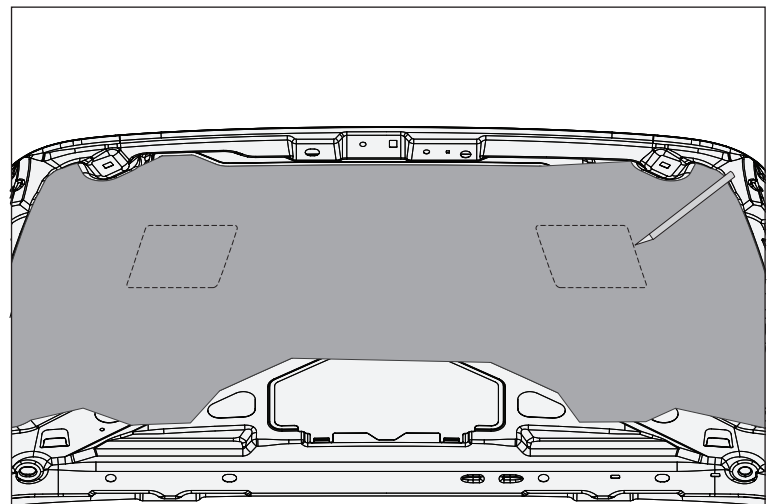



## PERFORMANCE HOOD VENTS

19. Place Hood Vent Inserts onto hood surface and align with mounting fastener holes. From underside of hood, insert supplied phillips head screws through holes created in steps 10 & 11 and use screwdriver to fasten Hood Vents in place.

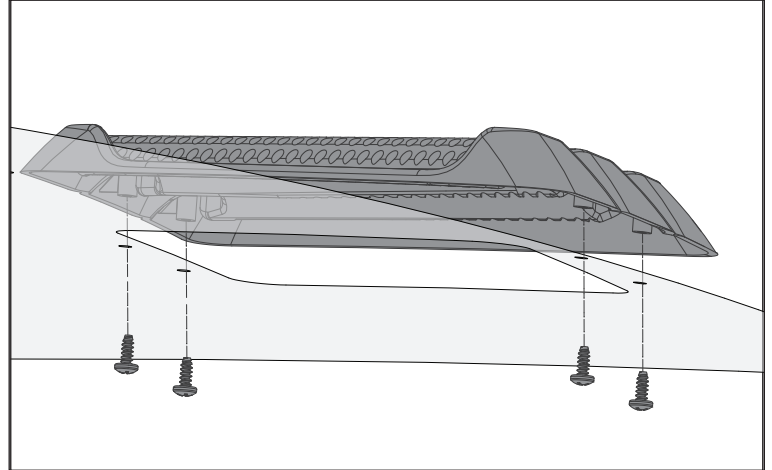

20. Re-install footman on OE hood. For TJ/LJ models, also re-install windshield bumpers.

21. Replace hood insulation blanket and christmas tree fasteners. (JK Only)

22. Raise hood and carefully remove blanket from step 5, making sure not to spill any debris into engine bay.

23. Close Hood. Step back, and marvel at the awesomeness!

