

AmFib Snorkel, JK

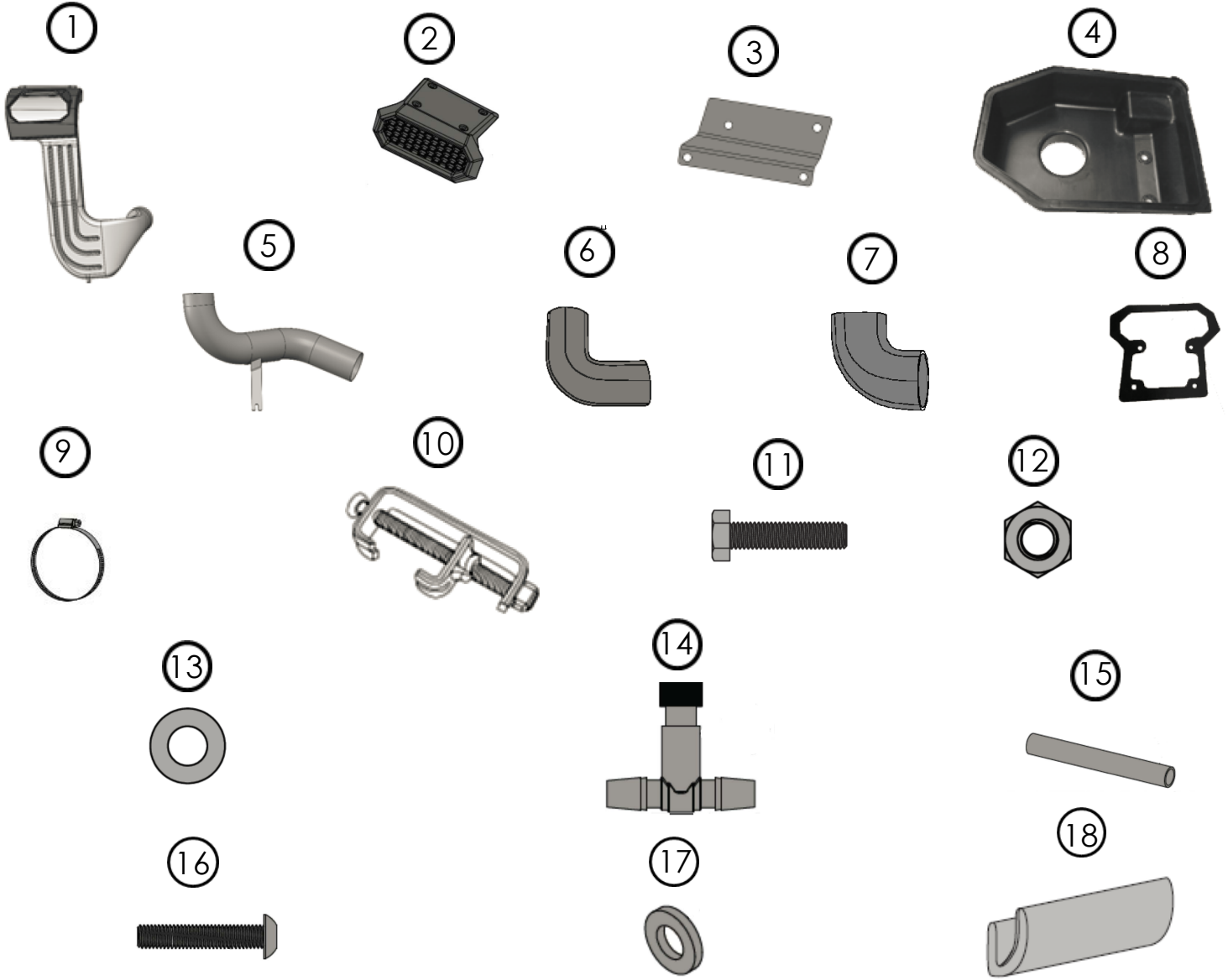

Components

1. Main Body.....	(1)	10. Air Box Seal Clamps.....	(4)
2. Low Mount Cover.....	(1)	11. M8 Hex Head Bolt.....	(2)
3. Z-Bracket.....	(1)	12. M8 Nut.....	(2)
4. Lower Air Box.....	(1)	13. M8 Flat Washer.....	(4)
5. Aluminum Tube.....	(1)	14. Regulating Valve.....	(1)
6. Silicon Elbow Long.....	(1)	15. Small Tube.....	(2)
7. Silicon Elbow Short.....	(1)	16. Short M6 Button Head Bolt.....	(4)
8. Flat Gasket.....	(1)	17. M6 Flat Washer.....	(4)
- " 3in Hose Clamps.....	(5)	18. Edge Trim.....	(1)



OMIX-ADA, Inc.

AmFib Snorkel, JK

High Mount Components

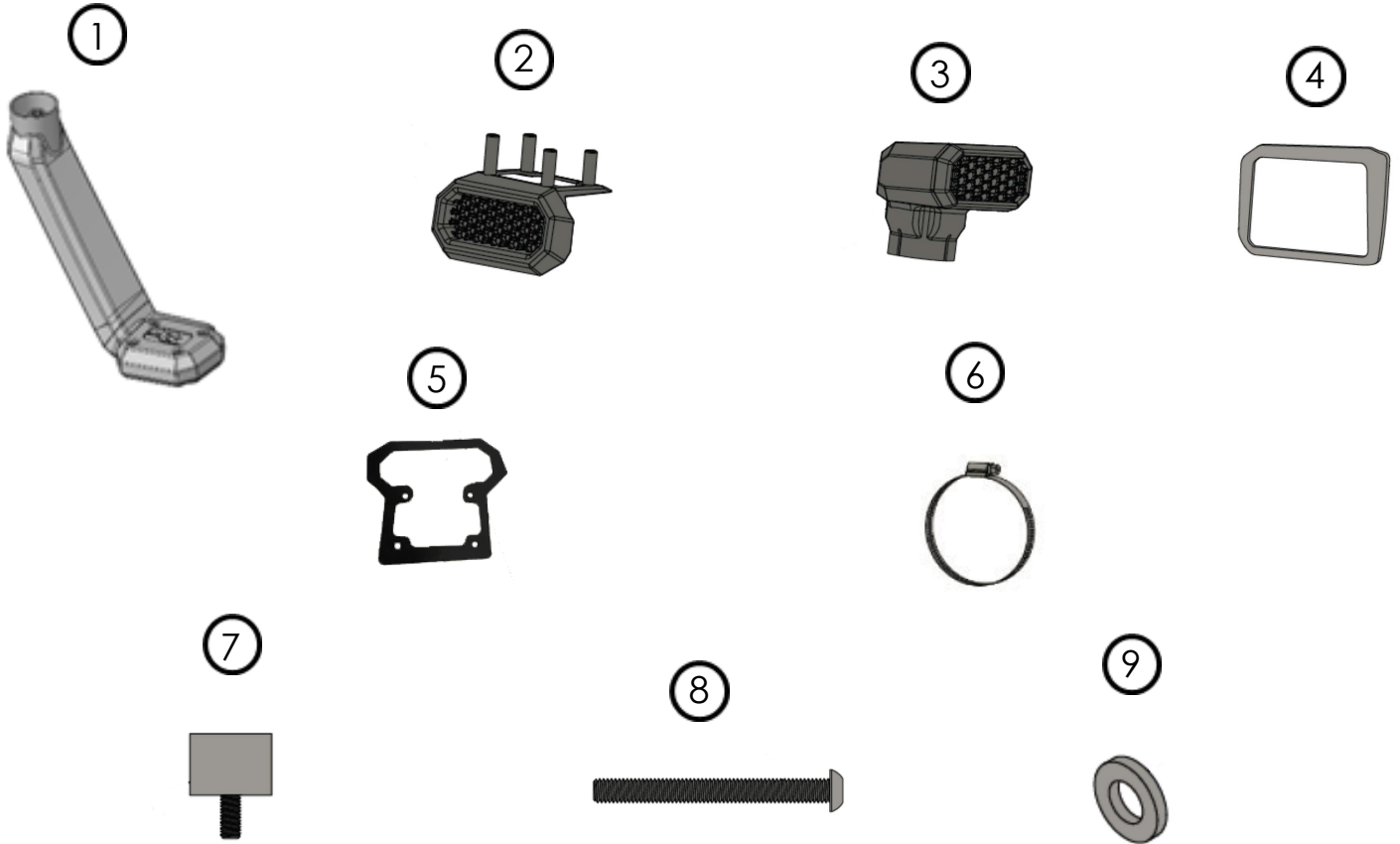

Components

- | | |
|-------------------------------|--------------------------------------|
| 1. Upper Tube..... (1) | 6. 3in Hose Clamp..... (1) |
| 2. High Mount Cover..... (1) | 7. Threaded Rubber Bumper..... (1) |
| 3. Ram Mount..... (1) | 8. Long M6 Button Head Bolt..... (4) |
| 4. High Mount Gasket..... (1) | 9. M6 Flat Washer..... (4) |
| 5. Flat Gasket..... (1) | |



AmFib Snorkel, JK

1. Using a T-40 socket, remove six bolts securing the right (passenger) Windshield Bracket. Remove and set aside.

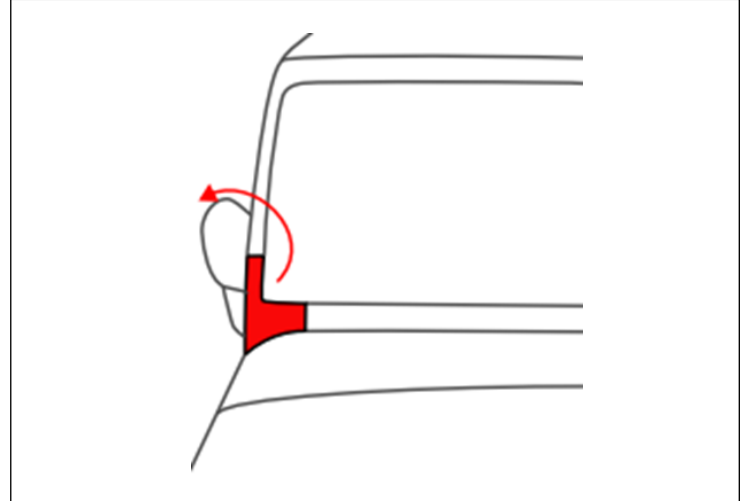

2. Using a 13mm wrench, remove both wiper arms.

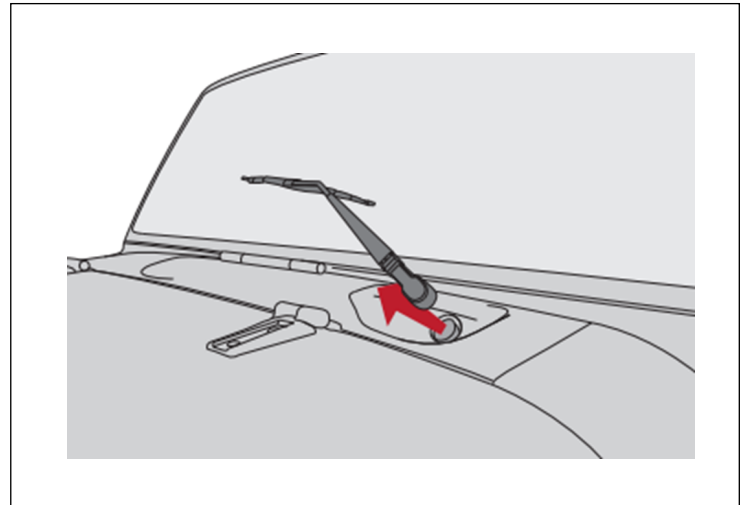

3. Remove cowl screws using T30 socket. Lift hood. Carefully remove cowl center plastic retainer clips using flat head screw driver and carefully remove cowl cover from vehicle. Close hood.

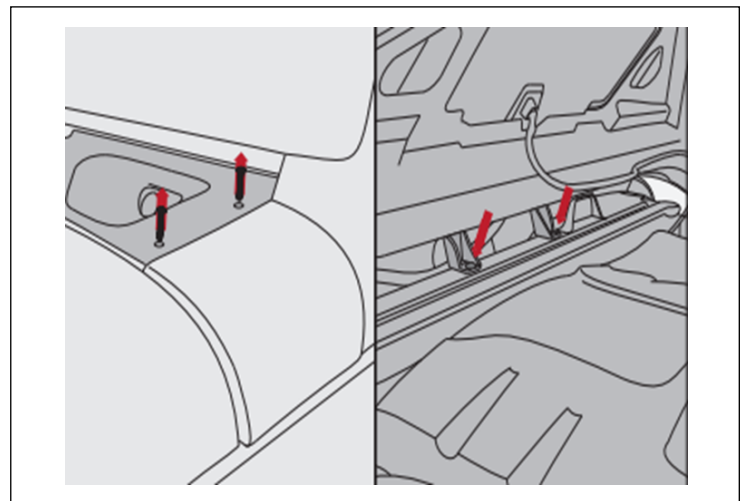



AmFib Snorkel, JK

4. Remove front passenger side door. Follow owner's manual instructions for removal of doors.

Using a 10mm wrench, remove top four fender bolts and loosen two fender bolts inside door jamb.

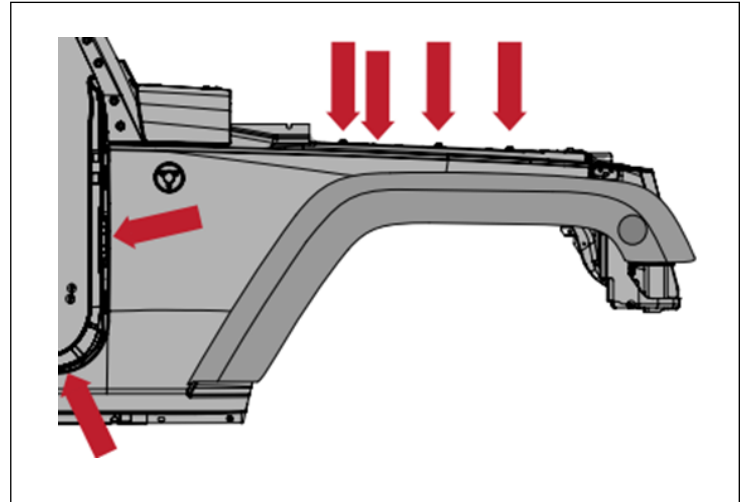

5. Remove two inner cowl bolts located under the Cowl Cover. OE bolts will be reused.

If top cowl section of fender is adhered to body, use small flat head screw driver or putty knife to release cowl section from body.

NOTICE Painters tape can be used to protect windshield paint if leverage is needed to release top cowl section.

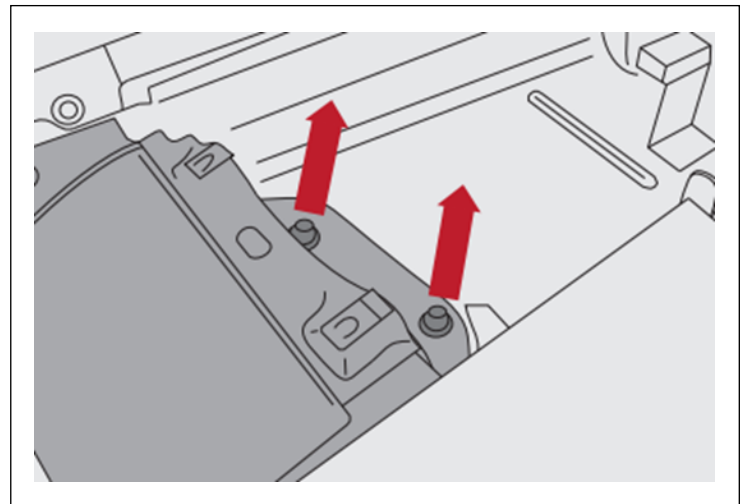

6. Remove 7 inner fender bolts and retain for later use. Remove lower pinch seam bolts.

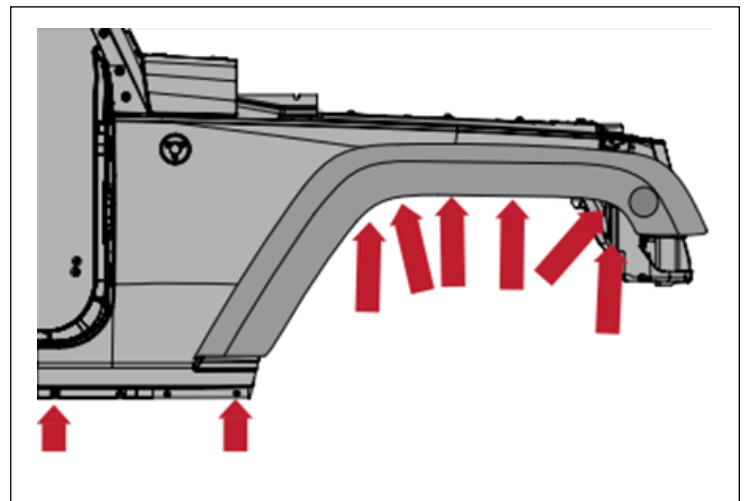



AmFib Snorkel, JK

7. Lift mounting brackets on top of fender away from fender using flat head screw driver or putty knife.

NOTICE Carefully pull fender assembly away from vehicle. Once fender is away from vehicle, disconnect radio antenna cable with pair of pliers in a twisting motion.

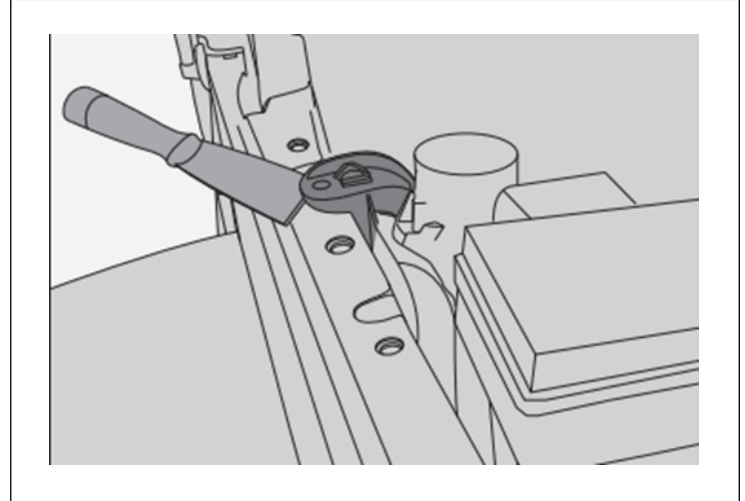

8. Remove Side Marker Bulb and disconnect wire harness, retaining clip from flare.

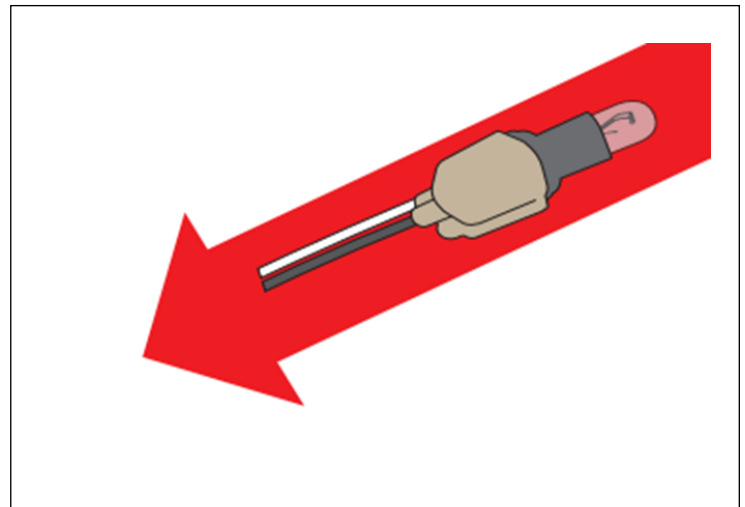

9. Carefully lift fender away from fender

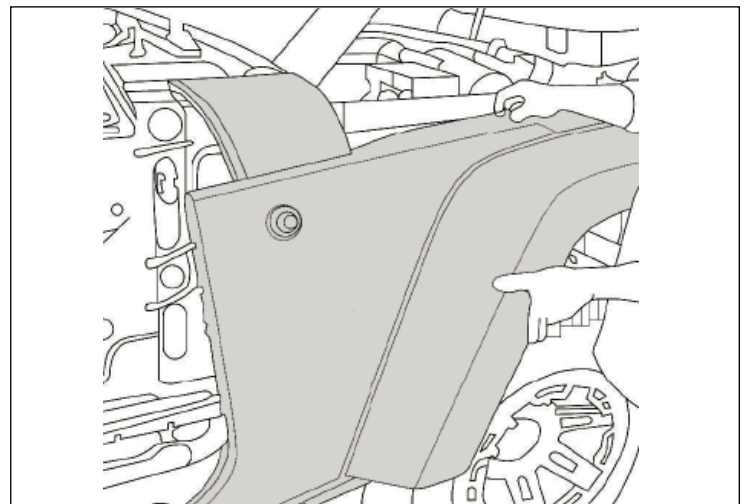



AmFib Snorkel, JK

10. OE Fender should be supported to avoid damage. Locate spot welds securing upper cowl to fender. Using a 1/8" drill bit, drill center guide holes into each spot weld. A wood block should be placed inside Cowl as guide holes are drilled to reduce any chance of damaging cowl sheet metal.

Enlarge 1/8" guide holes with 5/16" drill bit. Open guide holes making sure to place wood block over holes. With spot welds cleared, carefully remove Upper Cowl from fender and set aside.

NOTICE Fenders can be damaged if welds have not been opened completely.

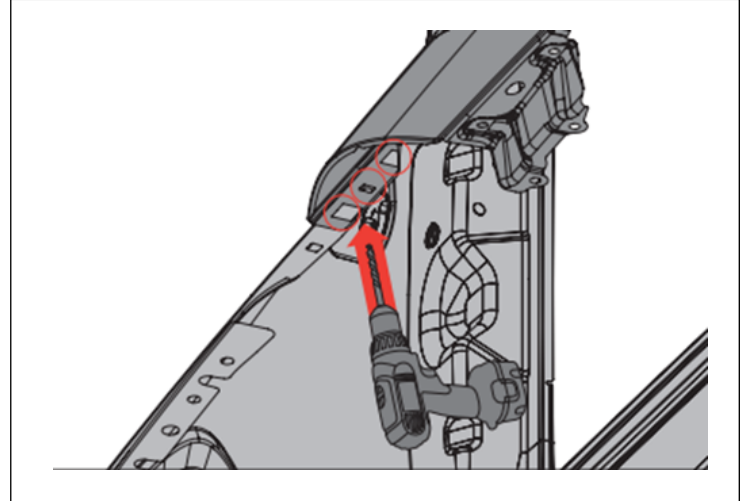

11. Cut fender using template provided on the last page of the instructions.

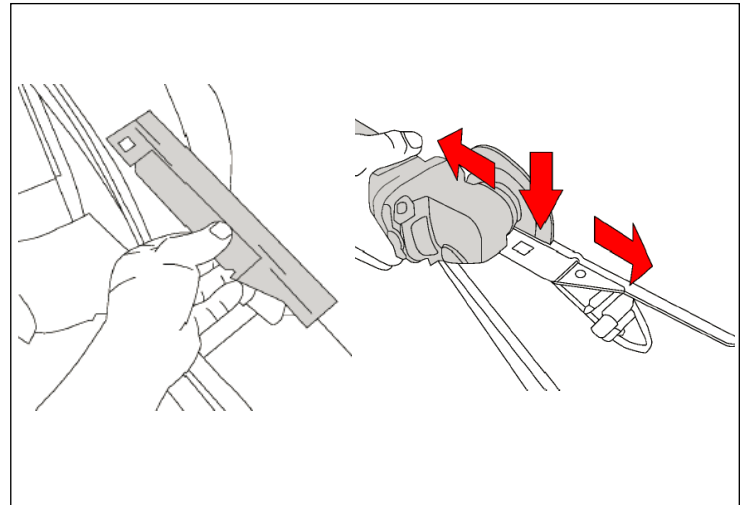

12. Apply edge trim to cutout area using super glue.

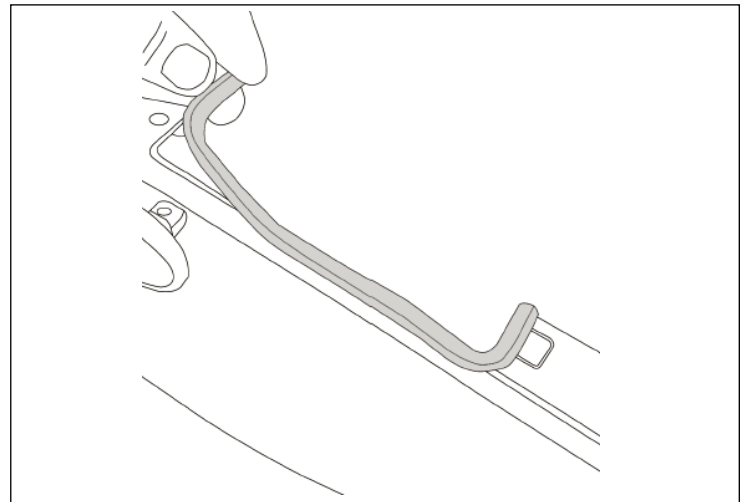



AmFib Snorkel, JK

13. Open Hood. Remove engine cover.

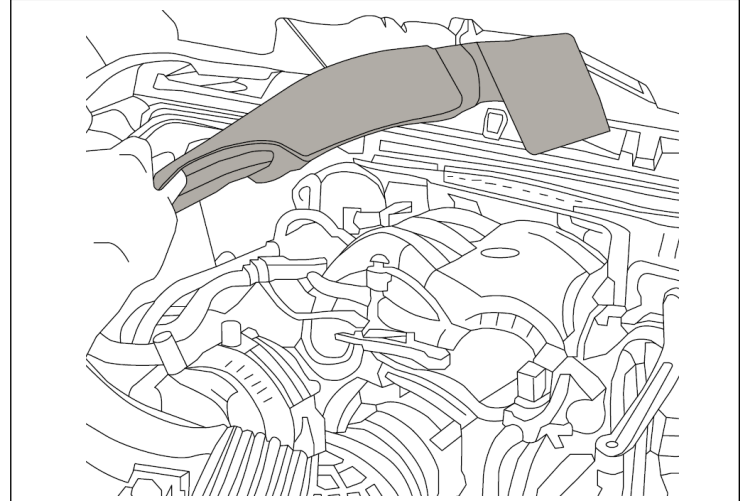

14. Unlatch upper air box and remove engine air filter. Loosen air intake hose clamps. Remove the two 10mm air intake bolts. Disconnect air flow (IAT) sensor from air intake tube. Remove air intake tube and upper air box cover from vehicle.

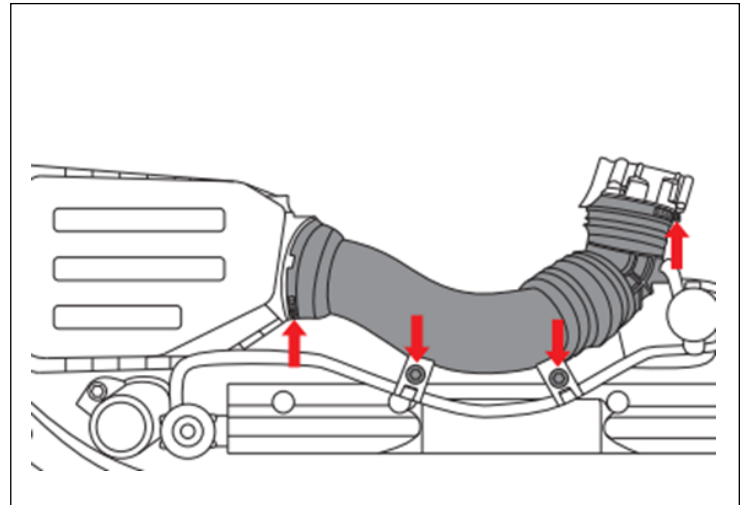

15. Loosen bolts from brake lines, located on the frame next to the shock.

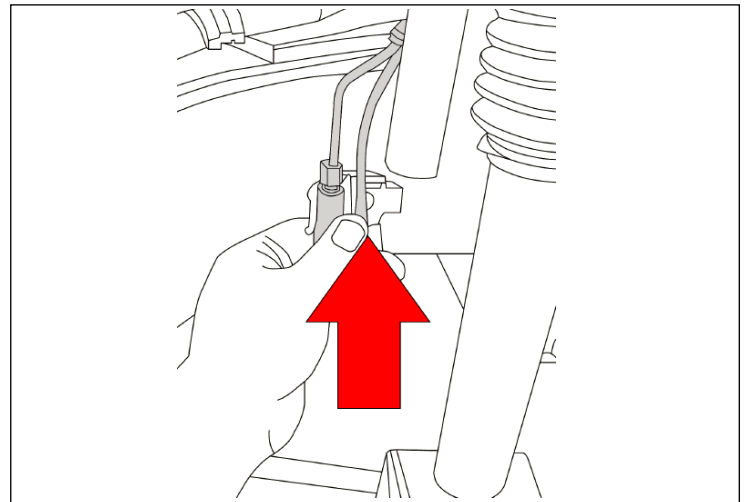



AmFib Snorkel, JK

16. Insert aluminum air tube from fire wall forward between shock tower and engine manifold.

NOTICE Exhaust manifold heat shield may need some clearance.

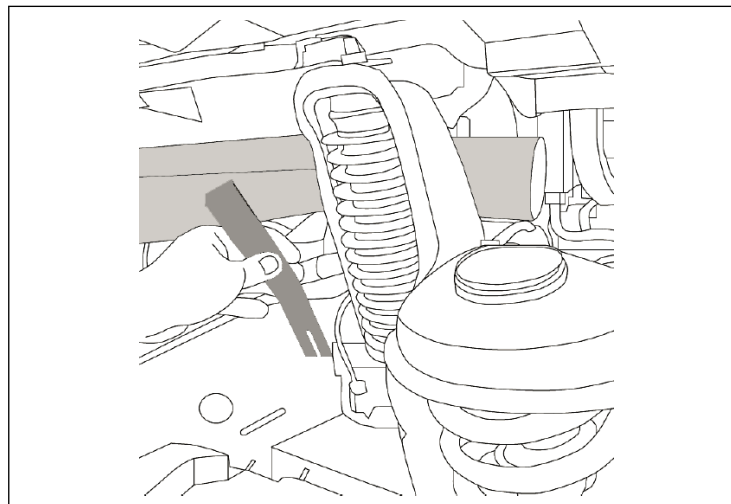

17. Inspect front of the air tube. Tube should rest just under the power steering pump hard line and next to idler pulley (arrows). The power steering hard line can be moved if needed. Carefully grab the line and pull up for additional clearance.

DO NOT OVER BEND LINE.

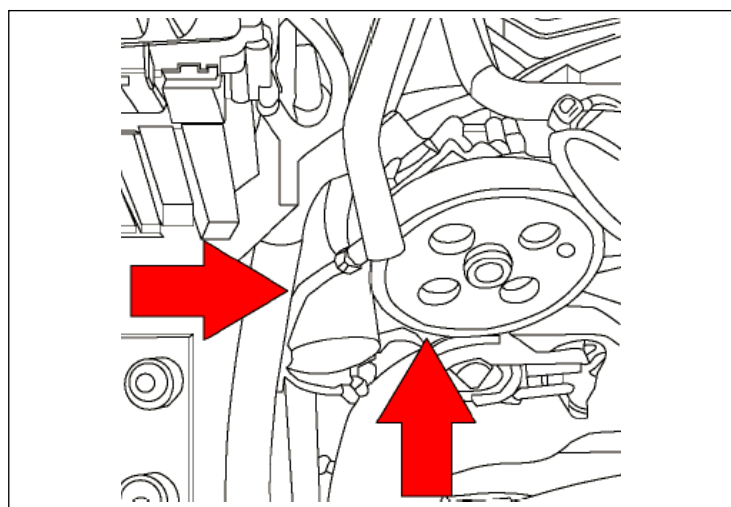

18. Place 3" clamps on both ends of aluminum air tube. Lower clamp should have screw face at the bottom of the tube facing outward as shown. The upper clamp should have screw face at the top facing outward.

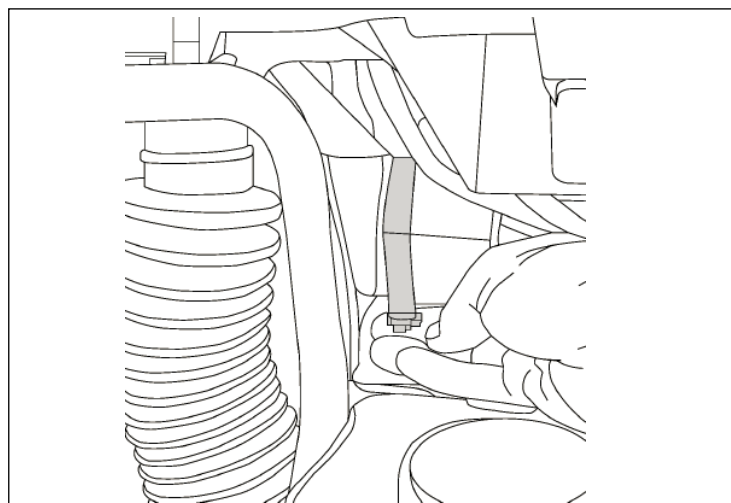



AmFib Snorkel, JK

19. Affix long Silicon elbow. Do not clamp or install hose at this time.

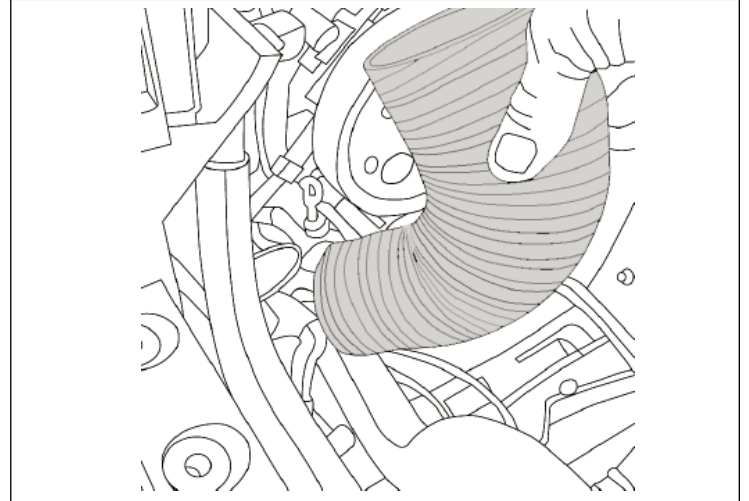

20. Align lower air box.

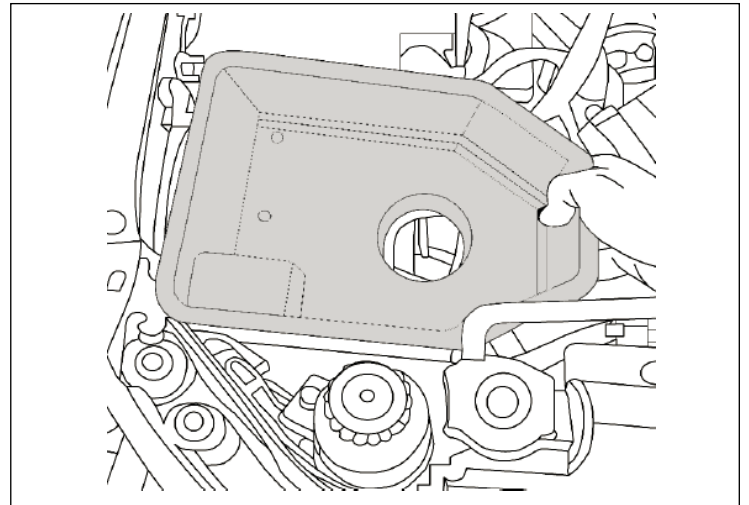

21. If there is a collision between the lower air box and long silicon elbow then trim long silicon elbow by 1/8".

If no trim is needed skip to step 23.

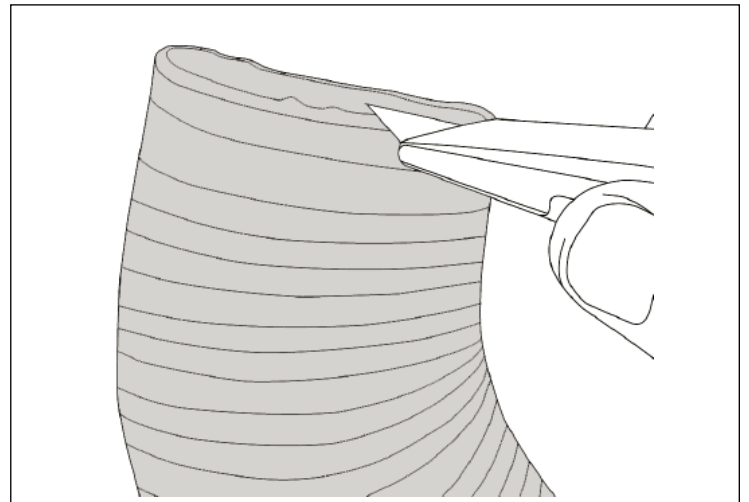



AmFib Snorkel, JK

22. With lower air box in correct location, 90 deg elbow attached to lower air box inlet, and aligned with aluminum air tube. Carefully remove air box and elbow together. Mark the position of elbow to air box. Remove elbow from air box.

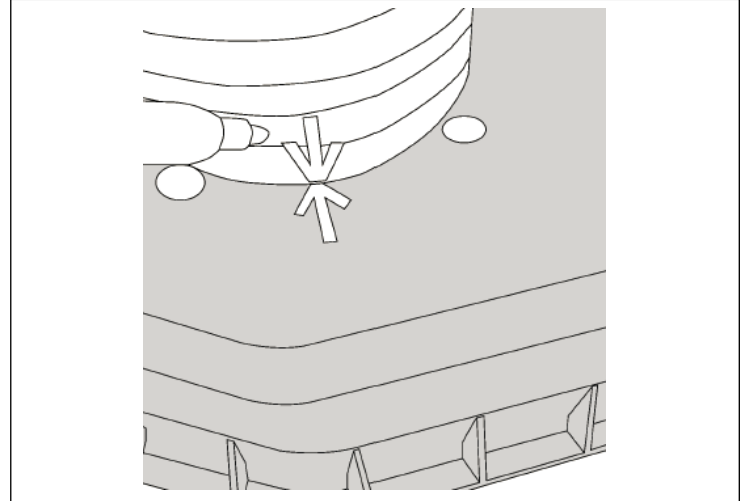

23. Apply small amount of sealant inside air box and silicon tube. Slide 3 inch Hose Clamp onto hose. Tighten hose clamp to air box.

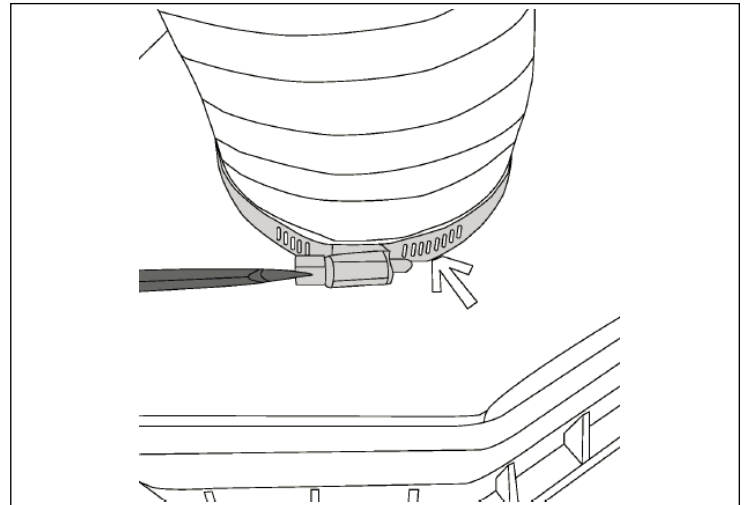

24. Apply a thin line of sealant around the end of aluminum air tube. An excessive amount may cause the elbow to slide off air tube when tightened.

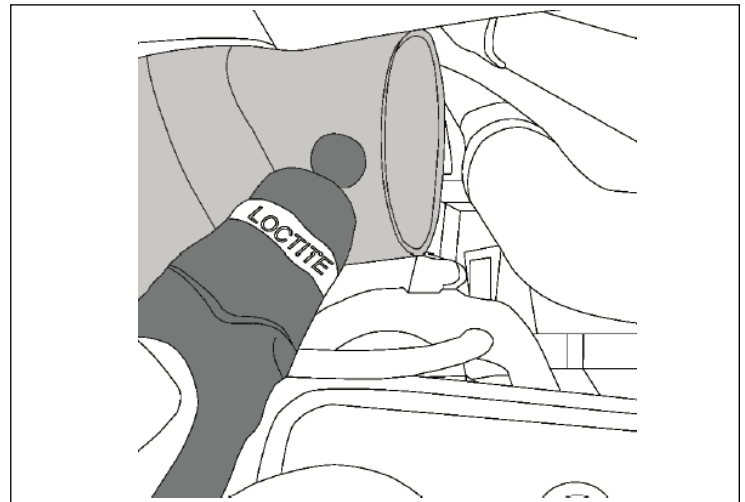



AmFib Snorkel, JK

25. Apply sealant to the inside of the two lower rubber grommets as shown. Make sure sealant completely fills the two holes.

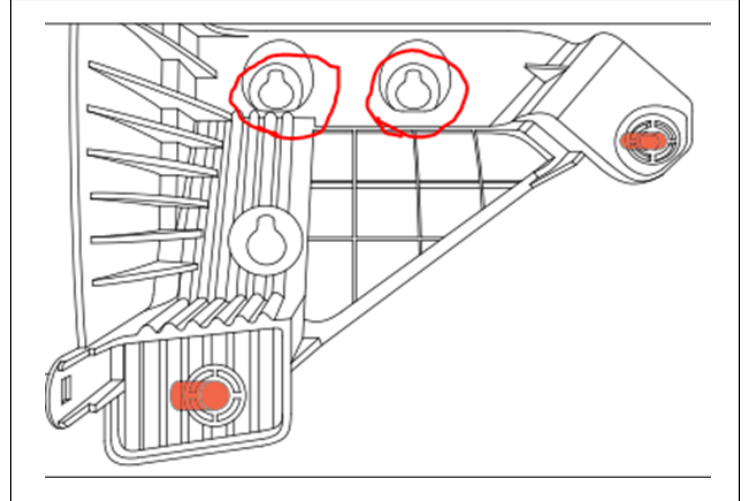

26. Reinstall lower air box and 90 deg elbow. Slide elbow over aluminum air tube. Apply extra sealant around outer edge of the elbow and air tube. Slide 3" clamp over elbow but do not tighten at this time.

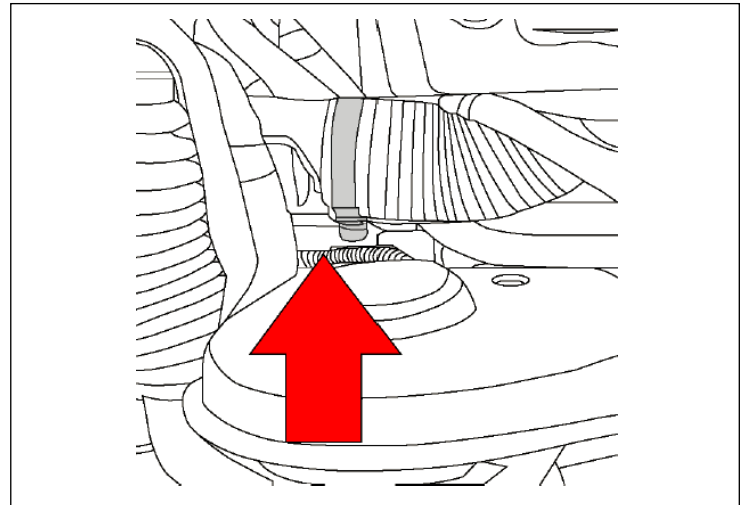

27. Attach lower air box to fender using M8 hardware. Apply small amount of sealant around washer before fully tightening.





AmFib Snorkel, JK

28. Painting the area behind the removed windshield plate is recommended (black). Quality painters tape and paint should be used. Liberally apply tape.

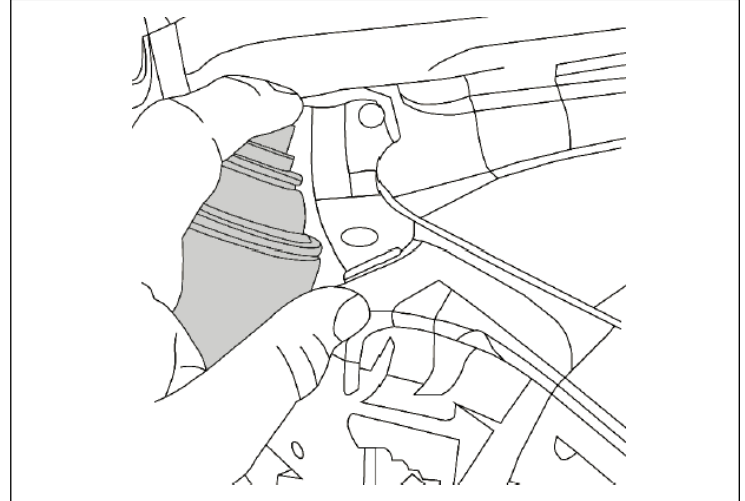

29. Reinstall windshield bracket.

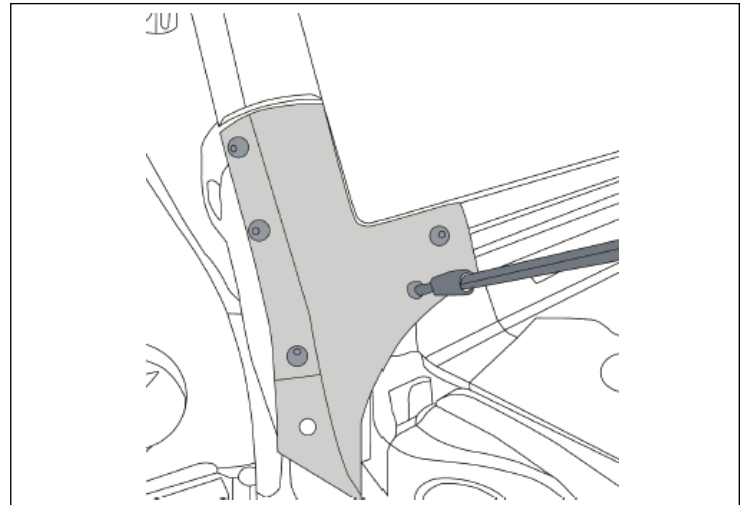

30. Install Z bracket reusing factory bolts. Attach U-nuts from Cowl (step 11).

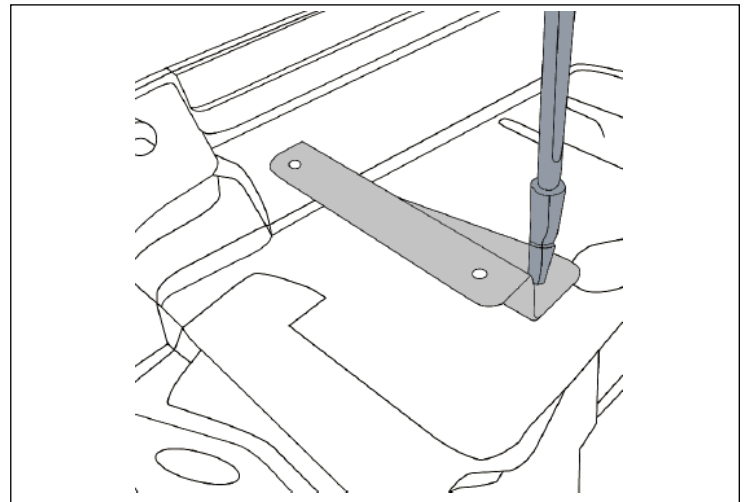



AmFib Snorkel, JK

31. Steps 32 to 34 are instructing installers to preform a dry fit before adding any sealant. Slide short silicon elbow on to main body. Loosely attach using 3in hose clamp.

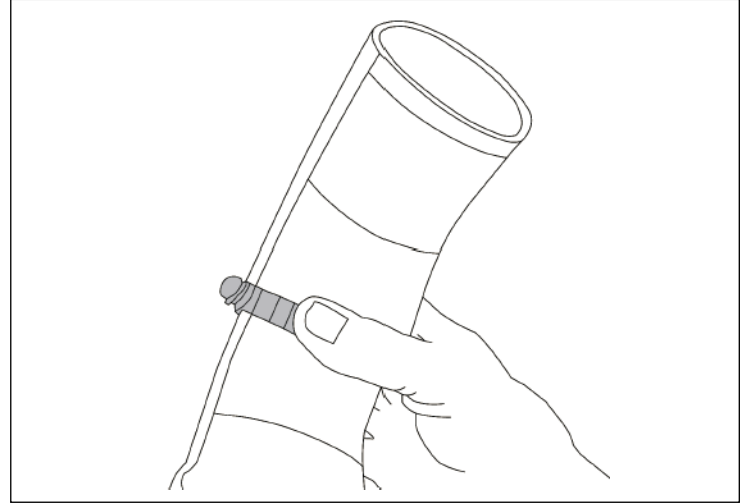

32. Position main body and silicon elbow on to the vehicle.

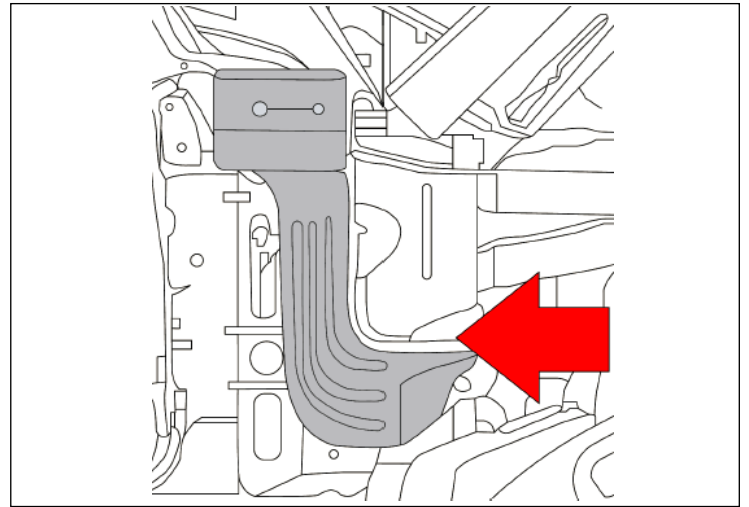

33. Slide short silicon elbow on the aluminum tube. Loosely attach using 3in Clamp. Make adjustments to aluminum tube or Z bracket then tighten hardware.

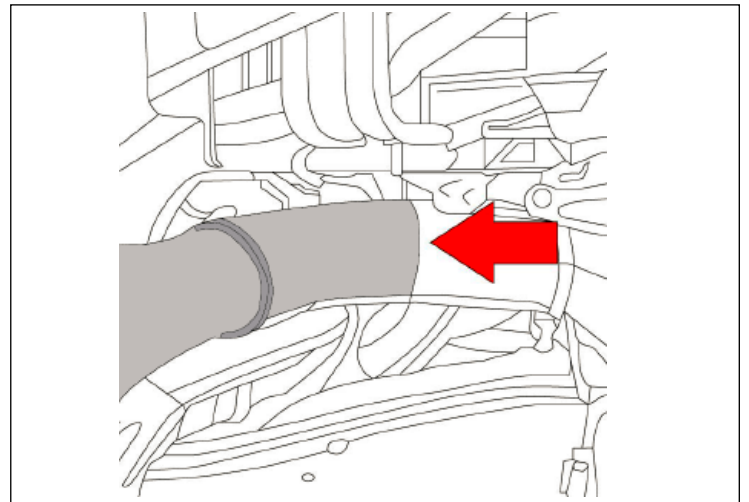



AmFib Snorkel, JK

34. Unmount main body and silicon elbow.
Apply sealant to the main body, aluminum tube, and silicon elbow.

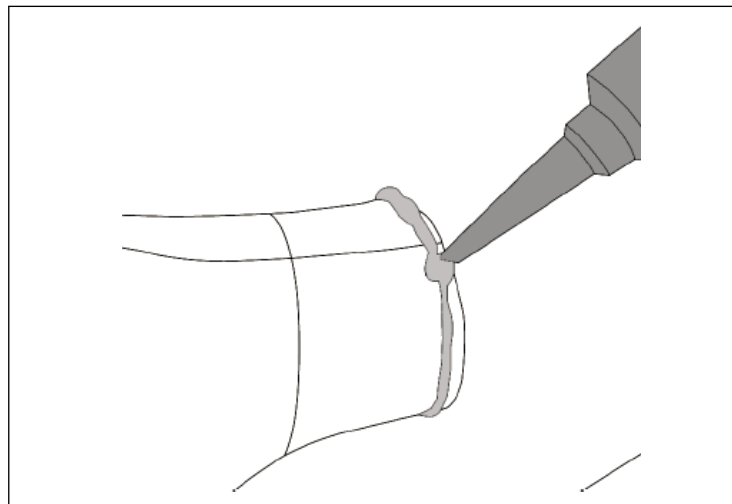

35. Reattach Main Body and Silicon Elbow Tube. Align Main Body to the Z-Bracket.

Reusing OE hardware, reattach Cowl Cover, Windshield Brackets, and Wiper Arms. Fully tighten all OE hardware.

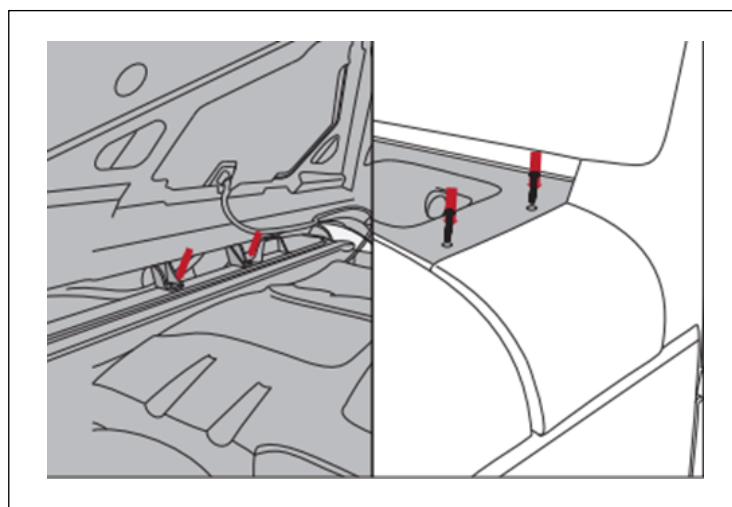

36. Attach drain hose, clamps, and valve to lower section of the Main Body.

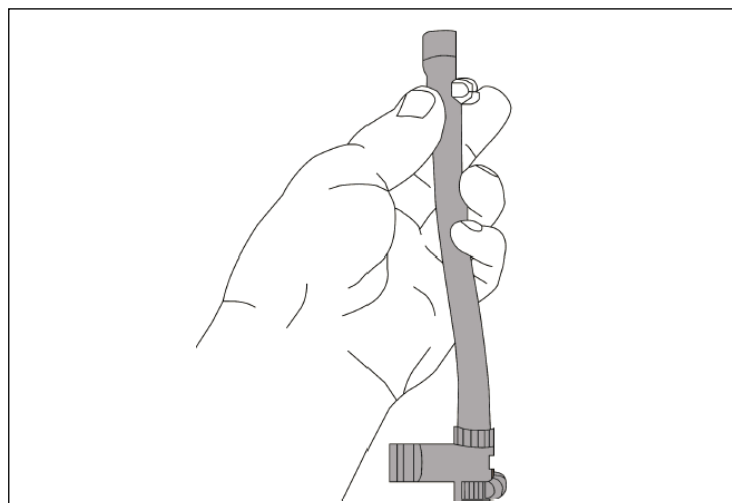



AmFib Snorkel, JK

37. Reattach Fender. (reverse of steps 5-10)

Tuck drain tube behind fender liner as shown in image.

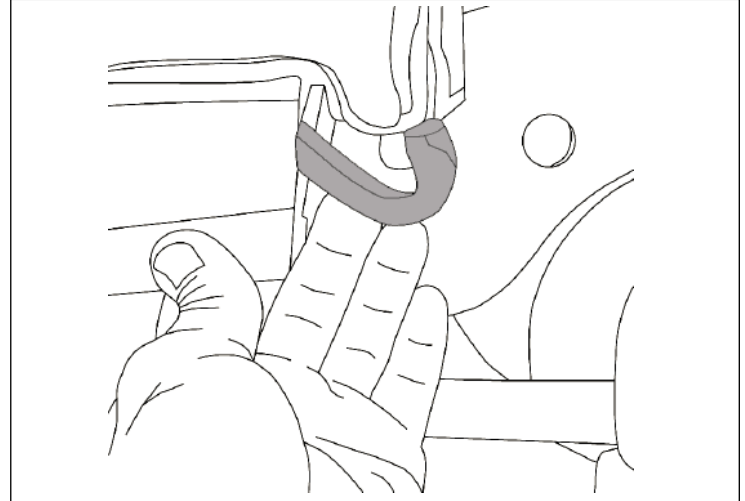

38. Apply flat gasket to bottom of low mount cover.

NOTICE If installing high mount skip to step 39.

Attach low mount cover to main body using short M6 button head bolts and washers.

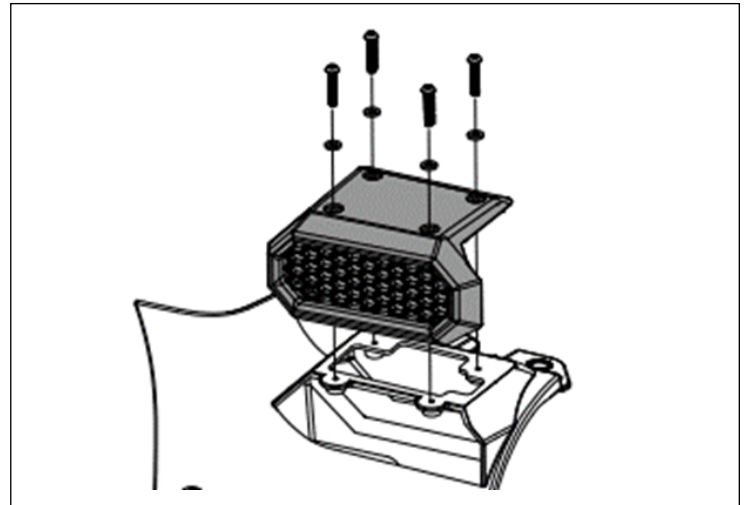

39. Apply flat gasket to bottom of high mount cover.

Screw rubber bumper to upper tube.

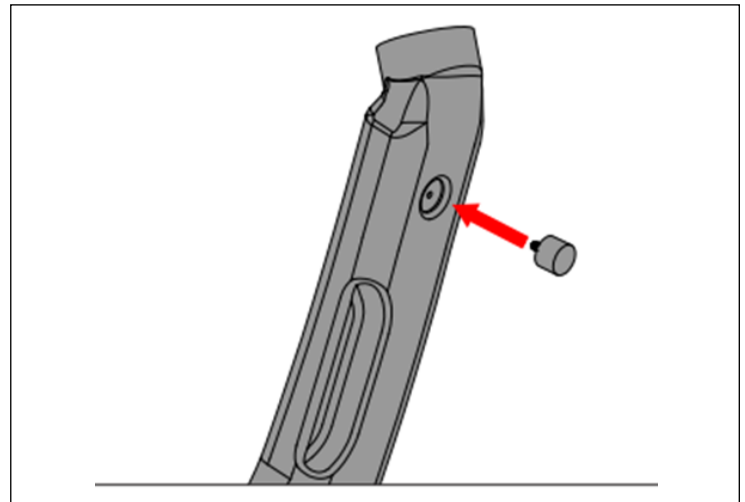



AmFib Snorkel, JK

40. Align high mount gasket to high mount cover.

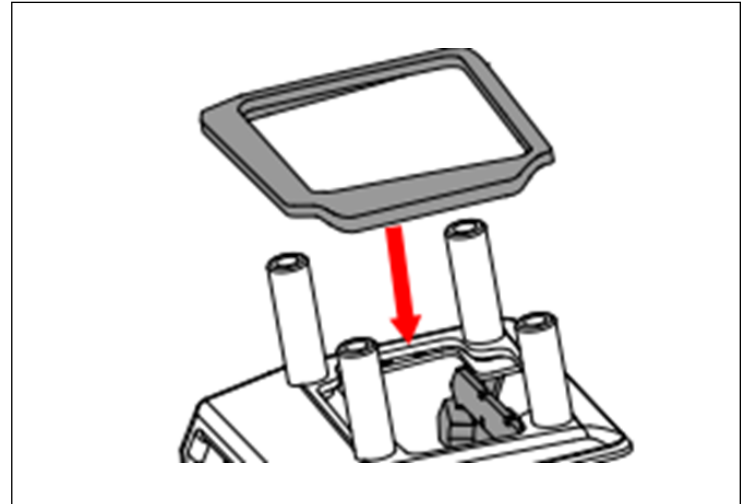

41. Align upper tube to high mount cover and main body. Using long m6 button head bolts and washers, attach high mount cover and upper tube to main body.

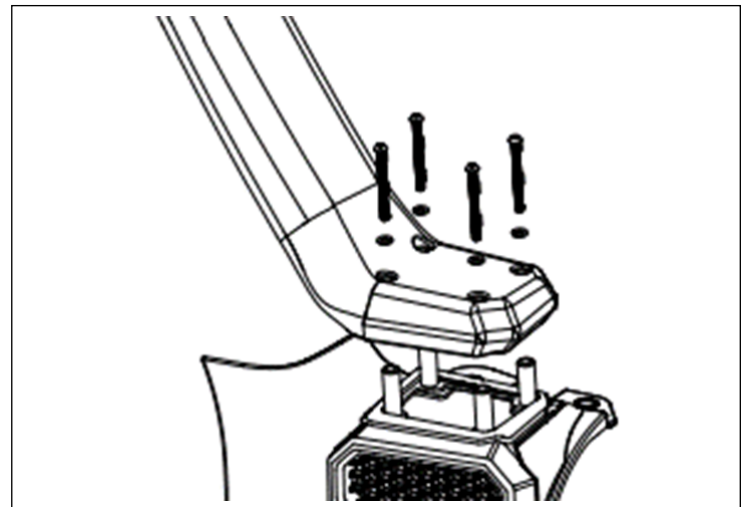

42. Using 3in clamp, attach ram mount or prefilter to upper tube.

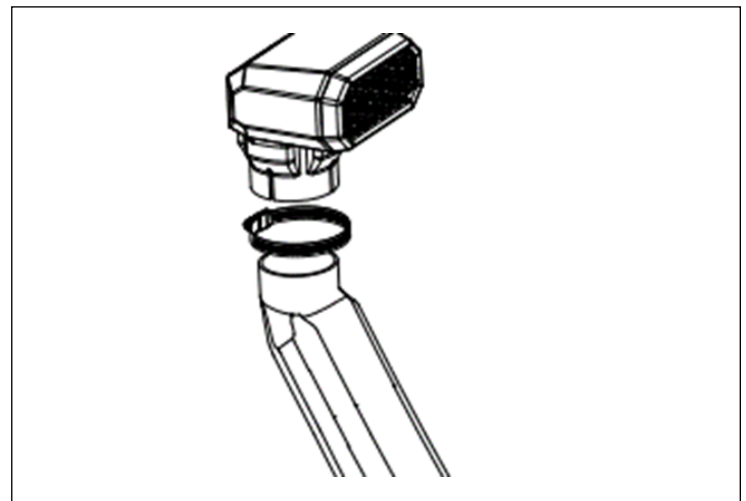



AmFib Snorkel, JK

43. Adjust rubber bumper so it will gently rest against the windshield.

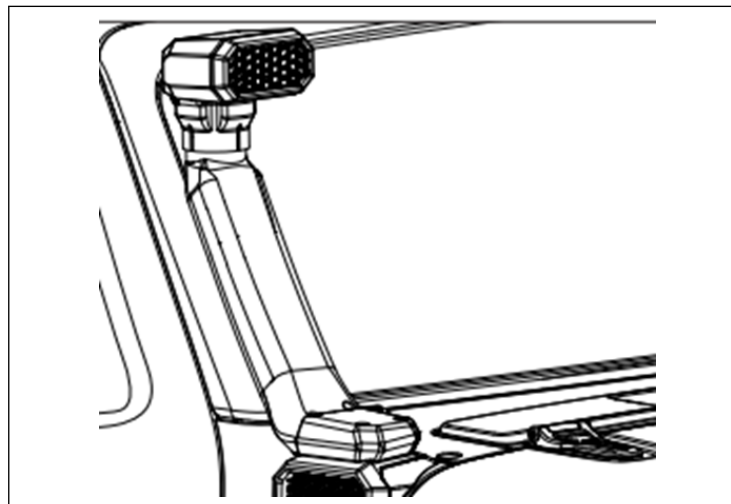

WARNING

The Rugged Ridge snorkel is designed to provide clean, dry air to the engine. There are many considerations to make when increasing a vehicle's fording depths. There are a variety of vehicle systems, beside the engine air intake, that are not intended to exceed the standard vehicle fording depth. It is the vehicle owner's responsibility to read and follow the owner's manual for appropriate water fording depths.

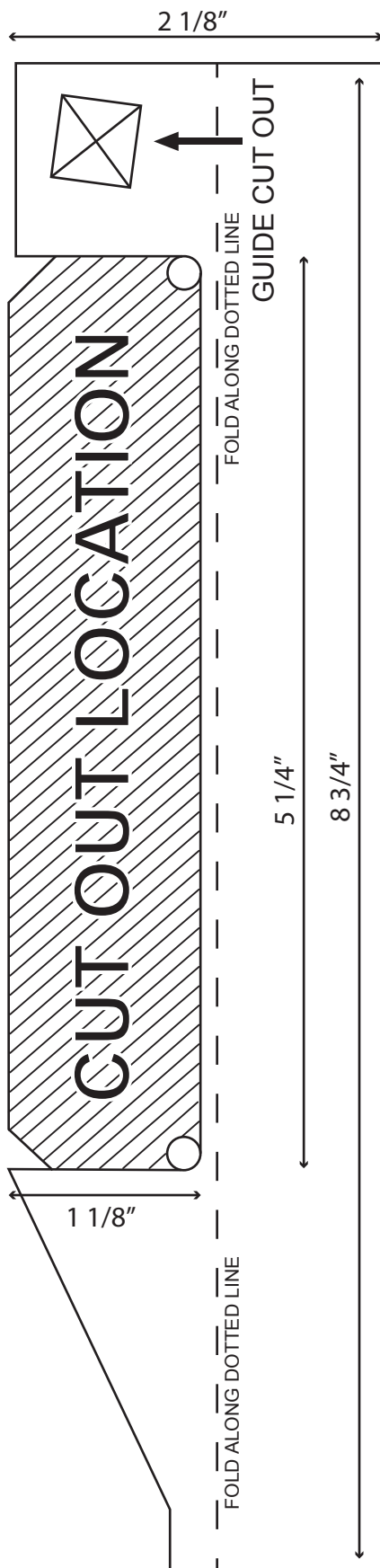
P/N: 17756.55**17756.56 - Fender Template (1:1 scale)**

Cut out template using scissors or X-ATCO blade. The template is a (1:1) scale guide for cutting top of passenger side (LH) fender.

NOTICE: Make sure guide cut outs align correctly with the top of fender. If guide cut outs **DO NOT MATCH** top of fender please contact Rugged Ridge for correct template. Template ratio can change size during the printing process. Every effort is made to insure correct sizing of template for installation but we do request that it is double checked prior to marking and cutting of vehicle fender. Failure to follow instructions may result in a poor fitting component or damage to fender.

Important Template information:

On PDF Print screen, chose option 'Do Not Scale' or 'Actual Size'.

This will print the correctly sized template. Correct template measurements are supplied for reference.

(Template length - Length 8 3/4" , Width 2 1/8")

(Cut Out Location - Length 5 1/4" , Width 1 1/8")

Questions regarding templete printing please call:

(770) - 614-6101 (Attn: Tech Department)

Snorkel system has been designed to reduce possible hydro locking caused by water entering intake system. The system is designed to provide dry, clean air to the engine and should not be used to exceed manufactures recommended fording depth. Proper off road driving technics should be used when fording any type of legal water crossing. It is the owners responsibility to judge conditions prior to placing vehicle in a situation where water intake is possible. The system should be used as a safeguard and not a full 100% sealed intake sytem. Rugged Ridge / Omix-Ada Inc. is not responsible for damages caused by improper installation an or use of snorkel system. System should be cleaned and flushed annually. Drain should be inspected and water expelled on a regular basis.

Manufactures warranty covers only products supplied by Rugged Ridge / Omix - Ada Inc.