

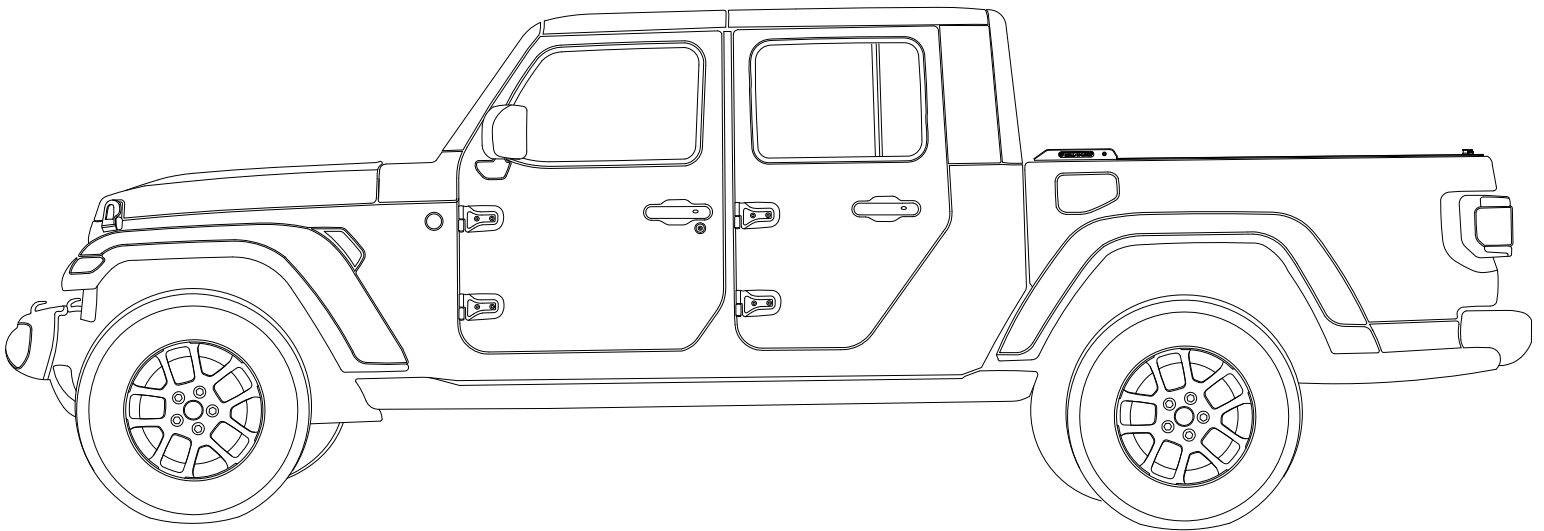

Installation Guide
Jeep Gladiator
with Mounting Channel



13550.34

Parts List

Item	Part Name	Qty.	Item	Part Name	Qty.	Item	Part Name	Qty.
A	Housing	1	H	#8 x 3/4" Self Tap Screw	2	O	1/4-20 x 3/8" Screw	4
B	Track	2	I	#10-24 Screw	2	P	Rubber Washer	4
C	Cargo Shield	1	J	Cargo Nut	2	Q	1/4" Lid Screws	2
D	Bulkhead Flashing	1	K	5/16" Socket Cap Screw	4	R	Drain Tube	2
E	Threaded Block	4	L	5/16" Lock Washer	4	S	Caulk Strips	2
F	Width Adjustment Shim	2	M	5/16" Flat Washer	4	T	Mounting Channel	2
G	Leveling Shim	2	N	Allen Wrench (1/4")	1	U	6mm x 25mm Pan Head	8
							303 Vinyl Protector	1

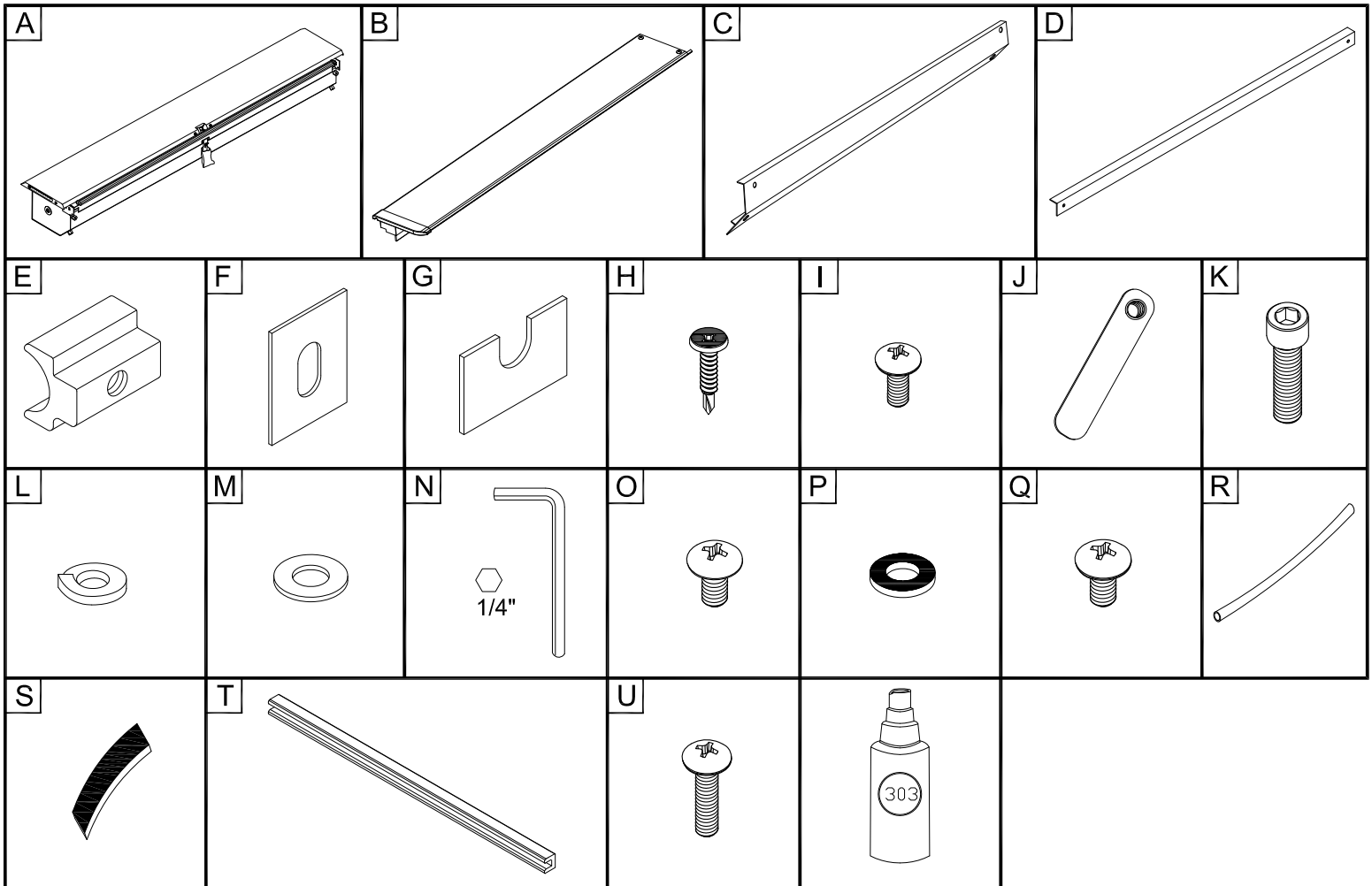

Tools Needed

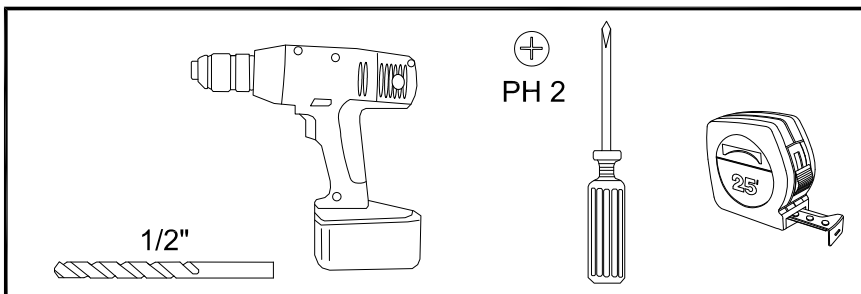

1a

If no plastic bedliner present proceed to page 4

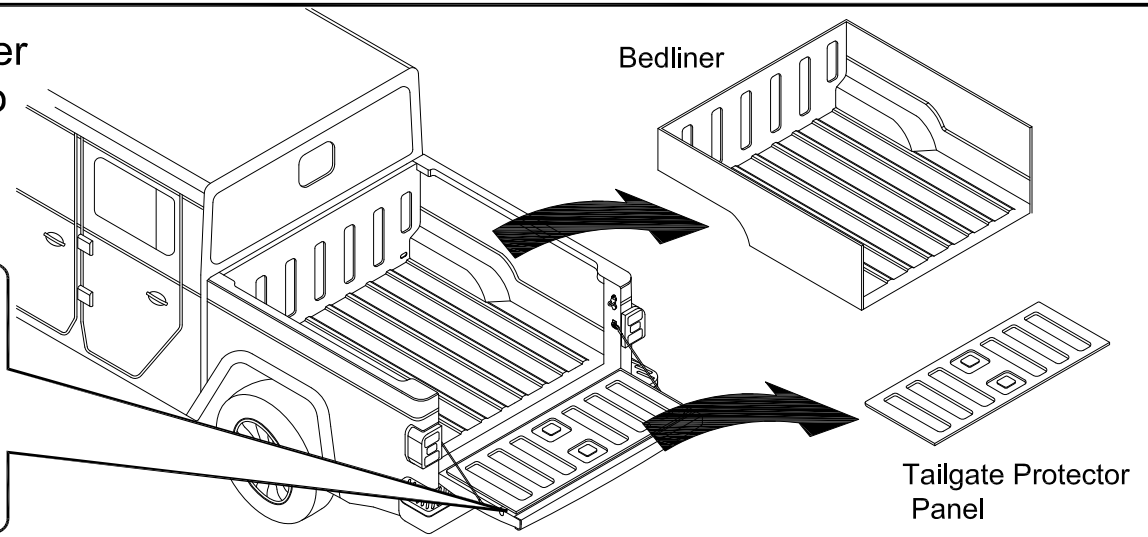
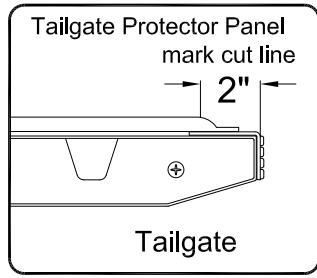

1b

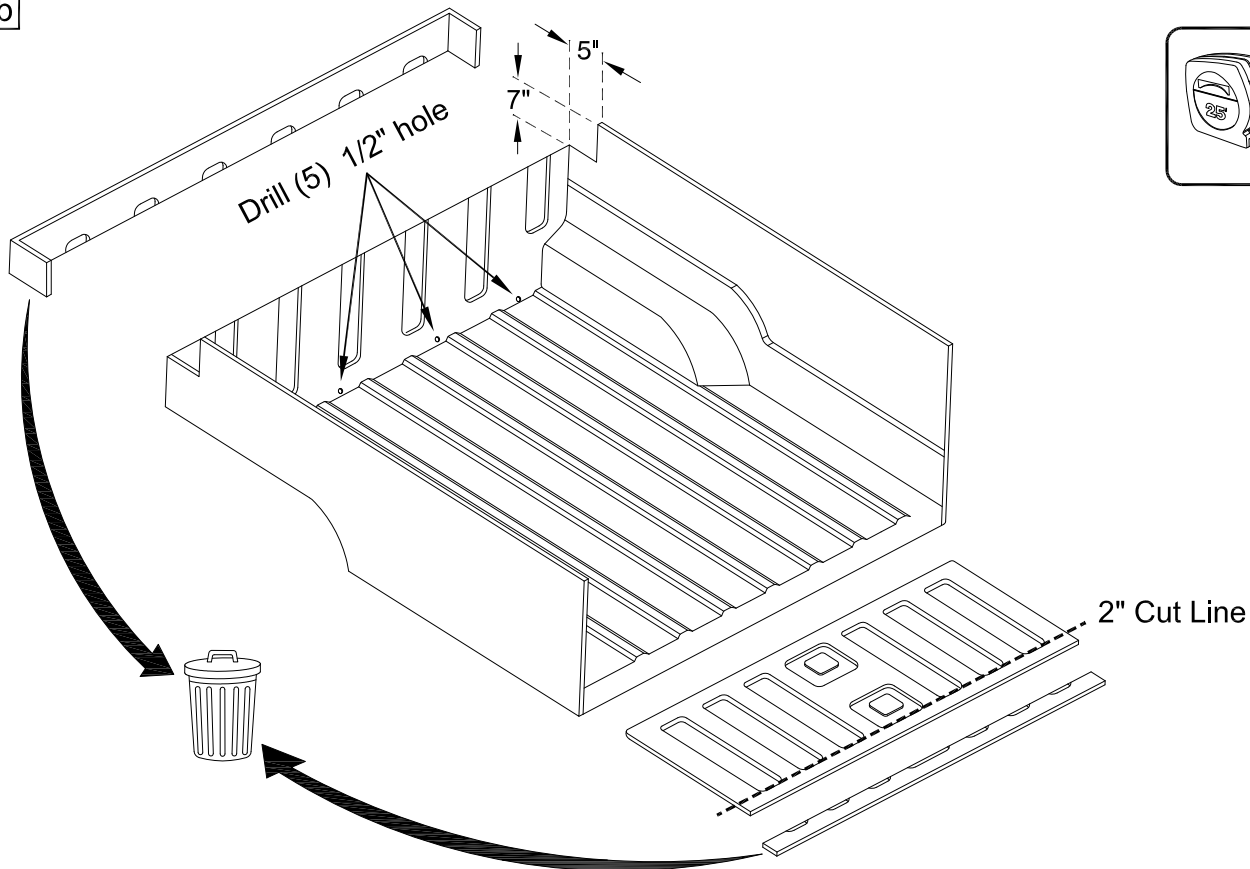

1c

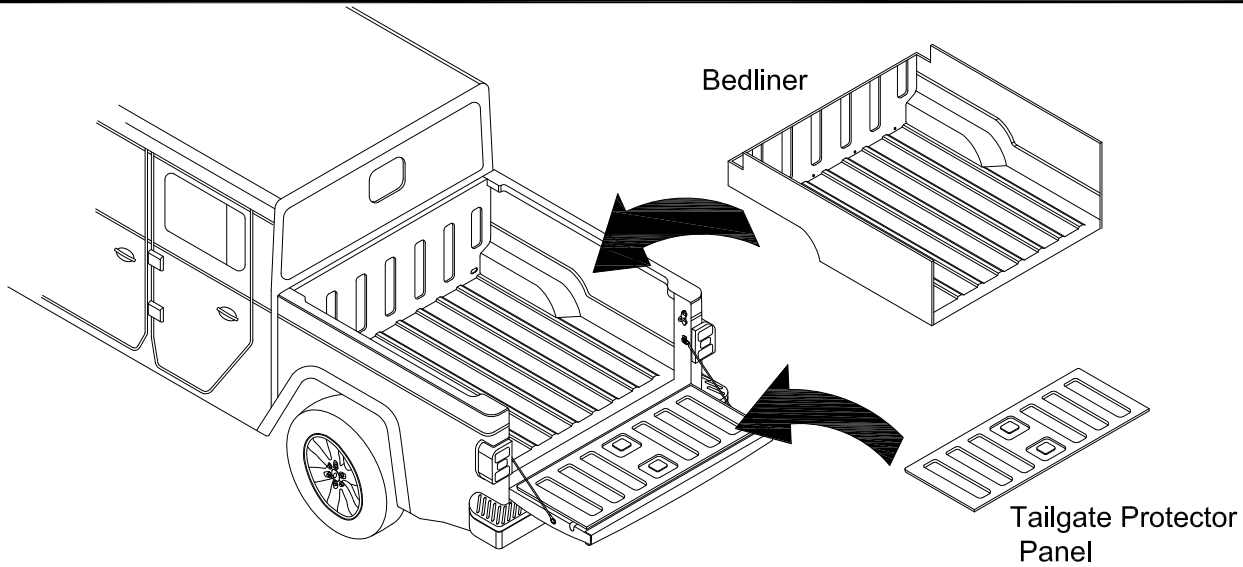

1

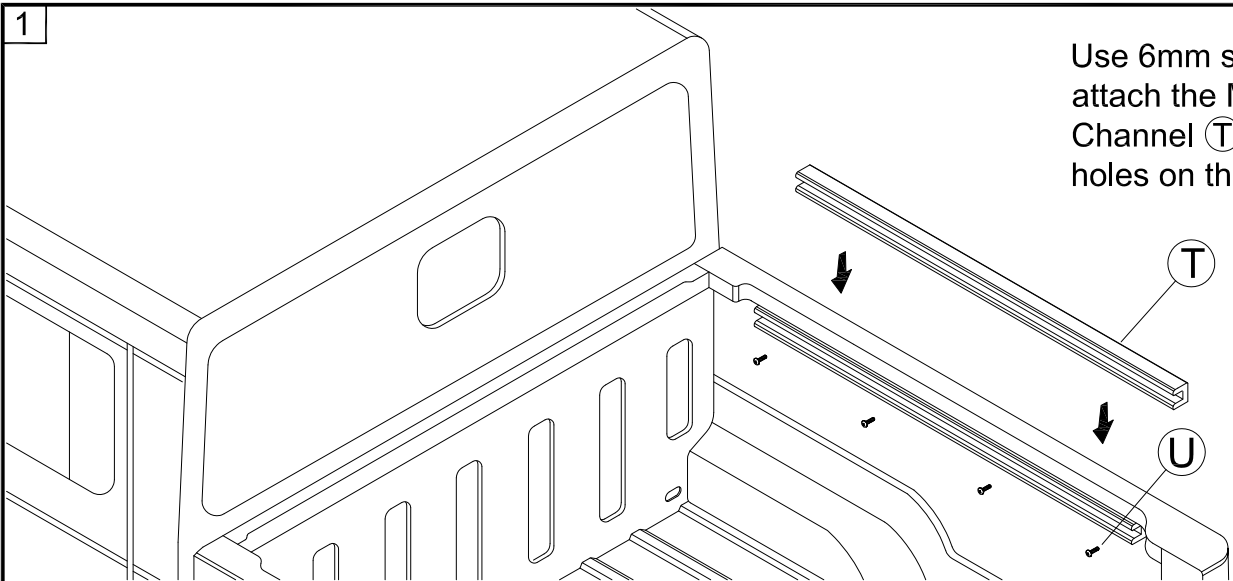

Use 6mm screws (U) to attach the Mounting Channel (T) to the existing holes on the truck side.

2

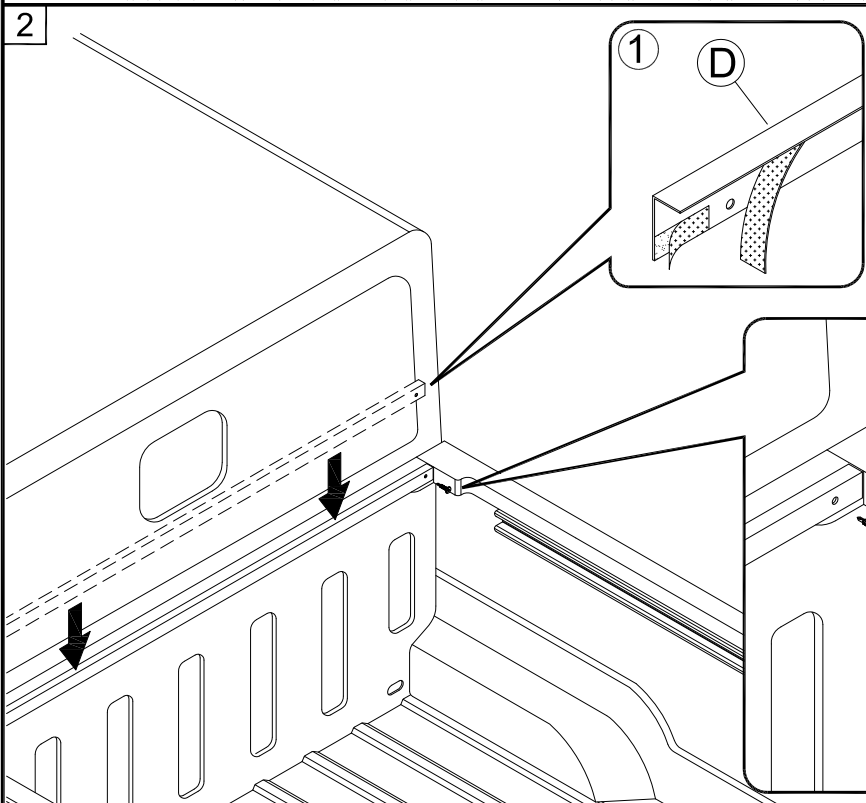

1. Peel backing from tape and stick Flashing (D) onto bulkhead.
2. Note Flashing orientation.
3. If needed use self tapping screw (H) to secure flashing at each end.

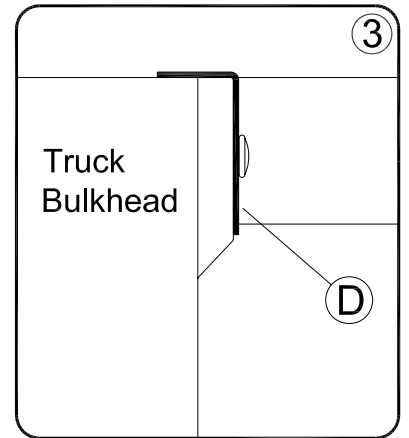
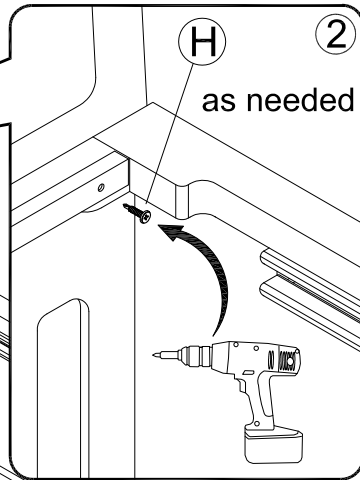

3

LHS = RHS

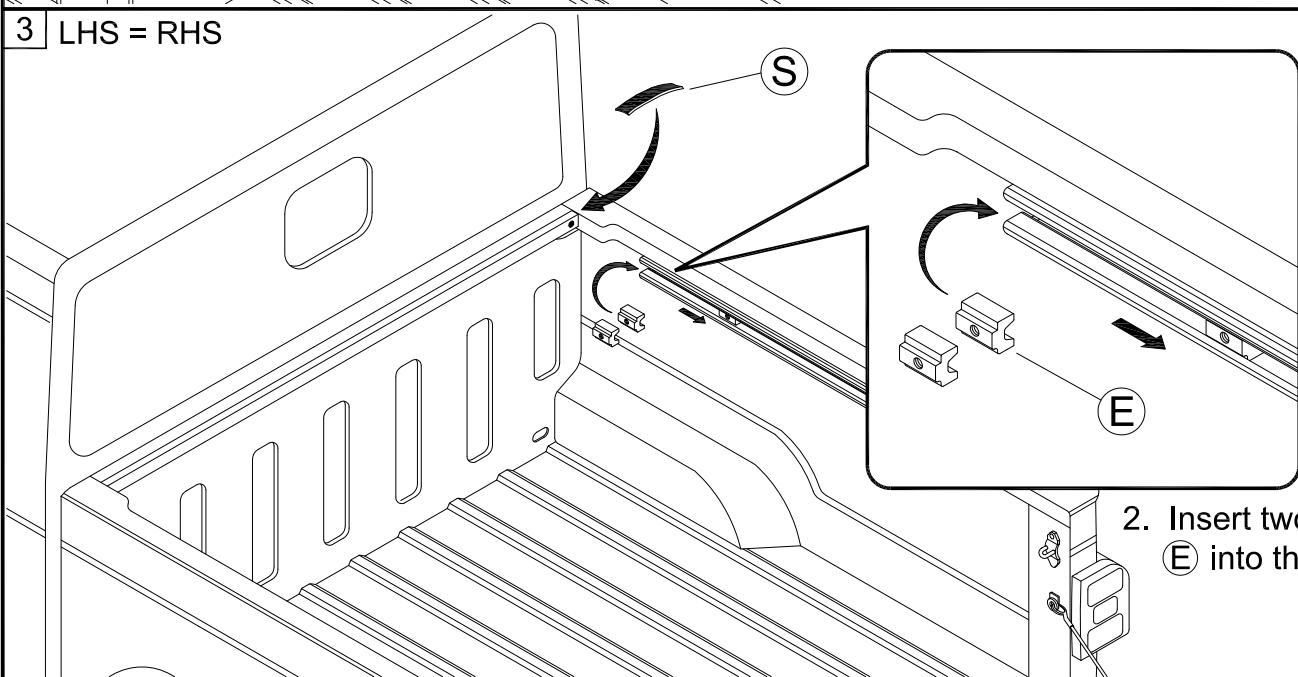

1. Press caulk strip (S) on seams to seal.

2. Insert two Threaded Blocks (E) into the channel.

4

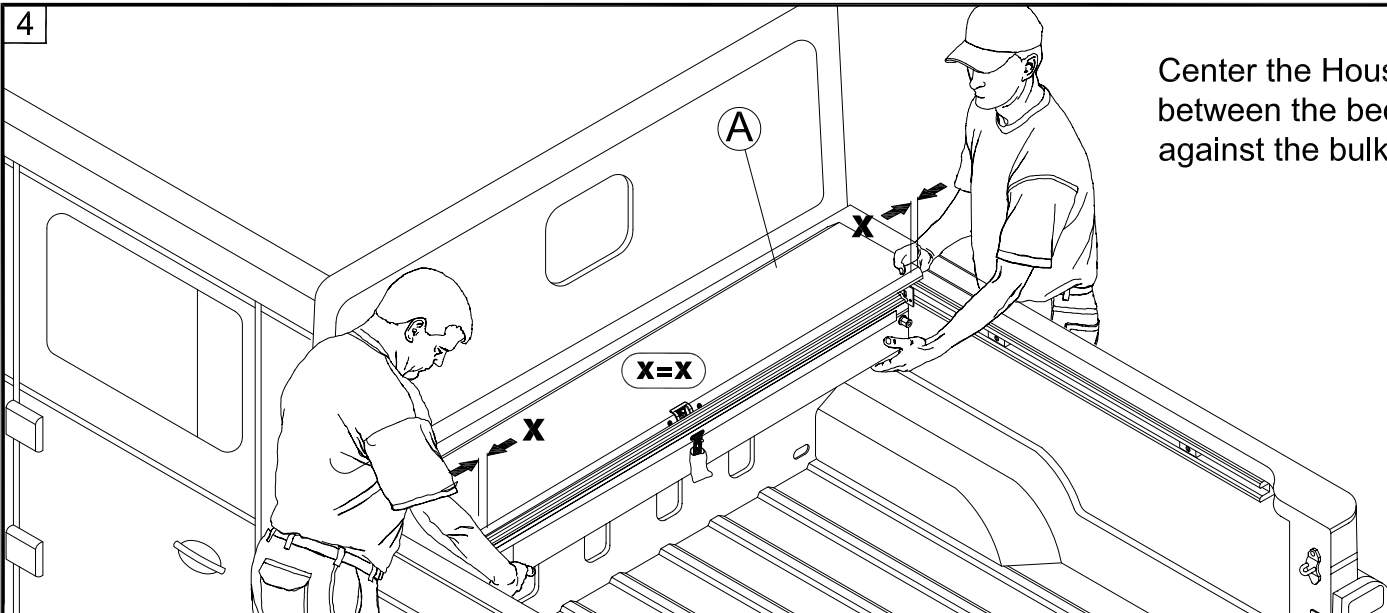

Center the Housing (A) between the bed rails up against the bulkhead.

5 LHS = RHS

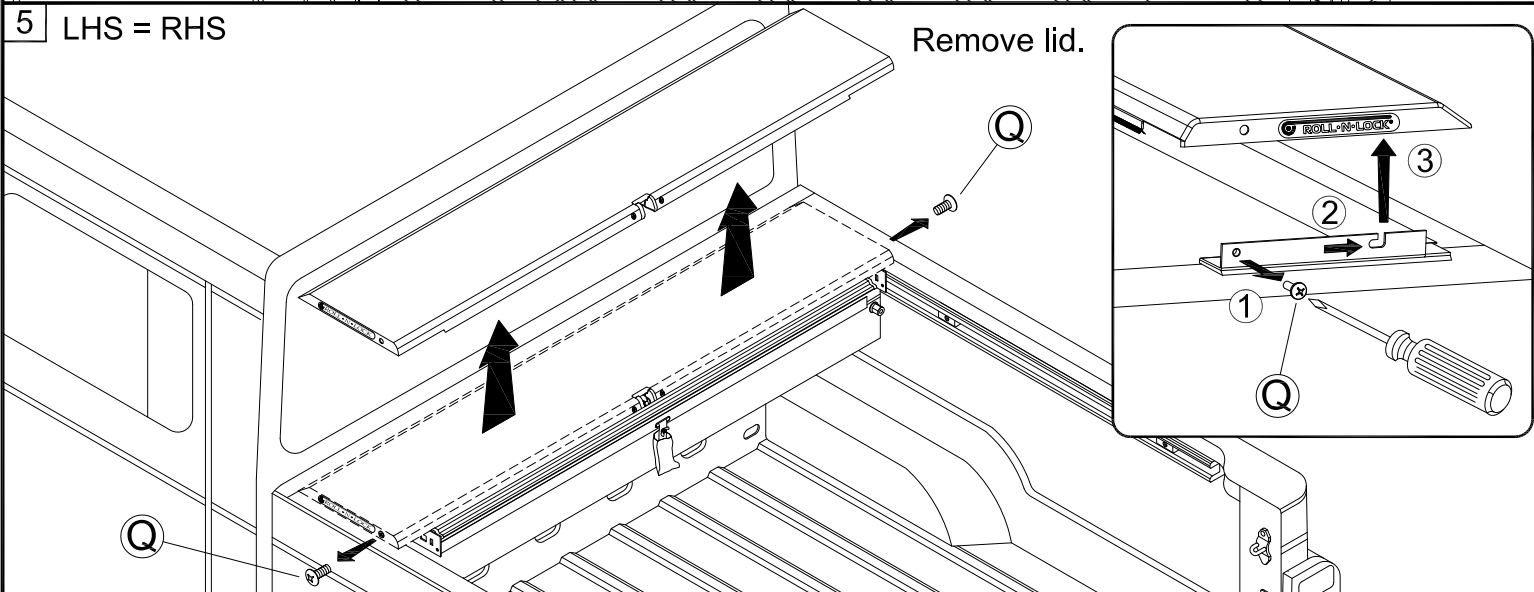

Remove lid.

6 LHS = RHS

Turn lock to 10 o'clock and key Tracks onto housing stems. Do not remove pull strap.

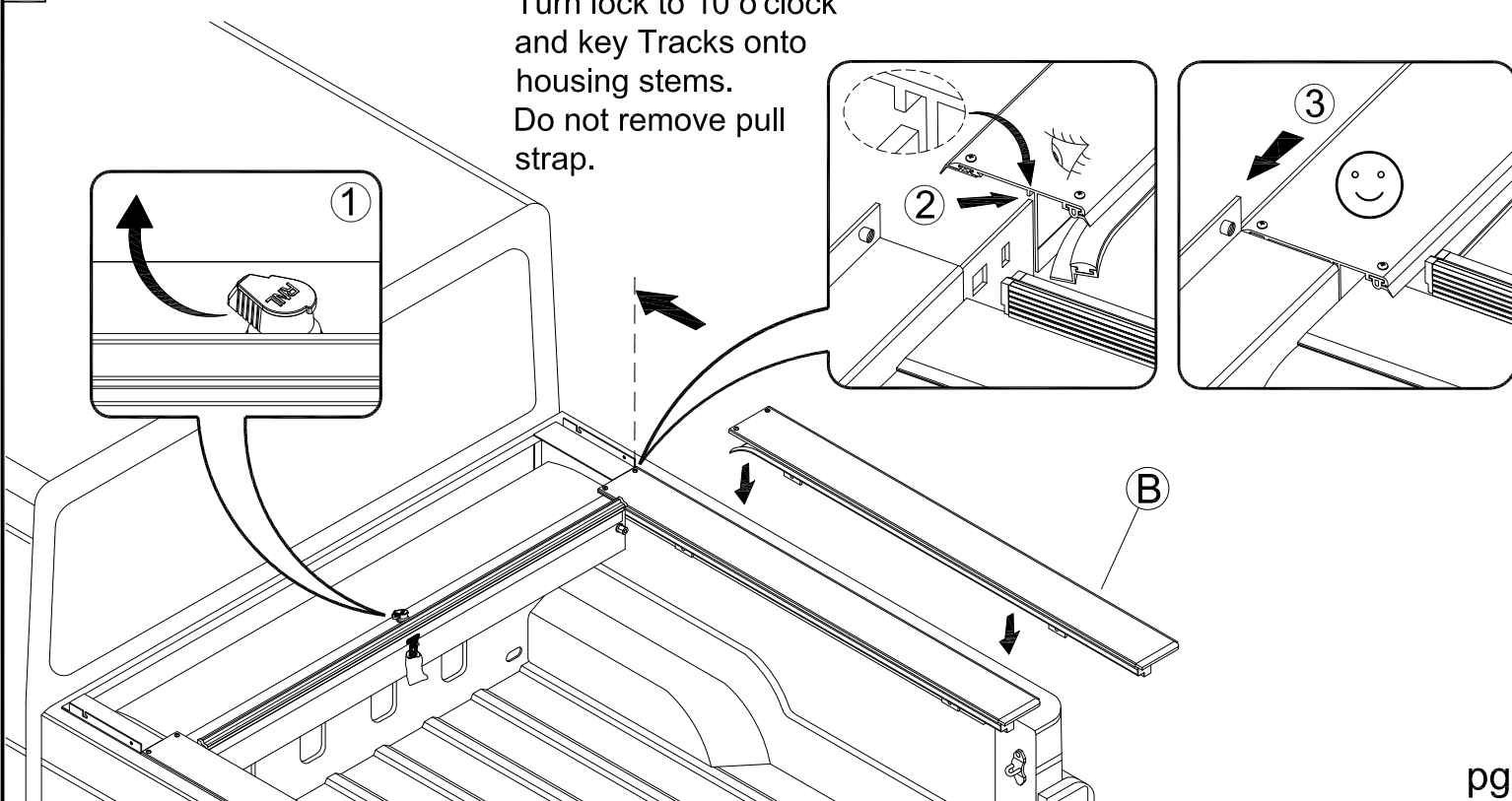

7 LHS = RHS

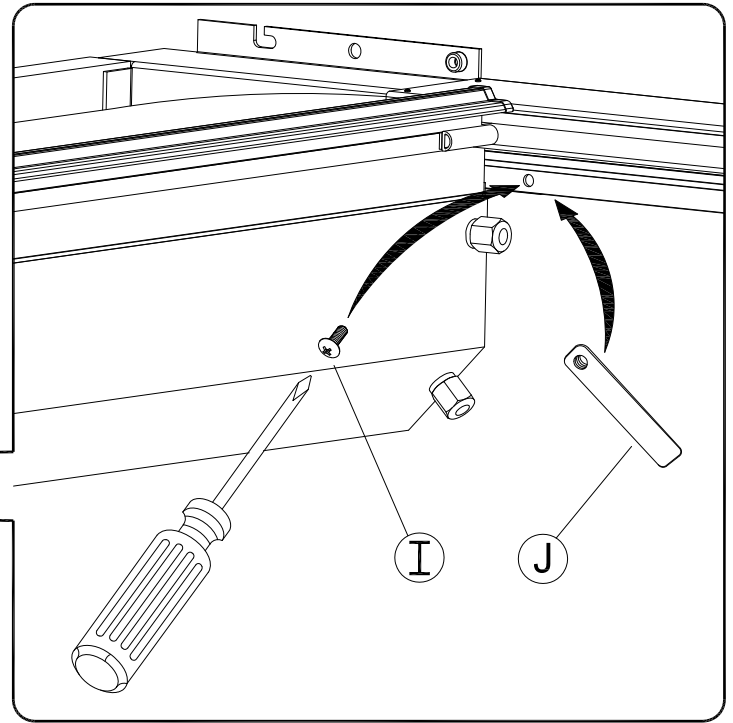
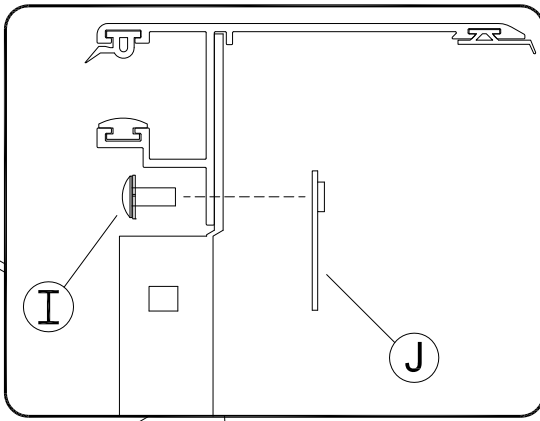

Secure Tracks to housing stems.

8 LHS = RHS

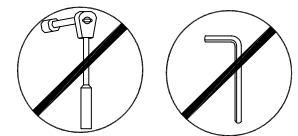
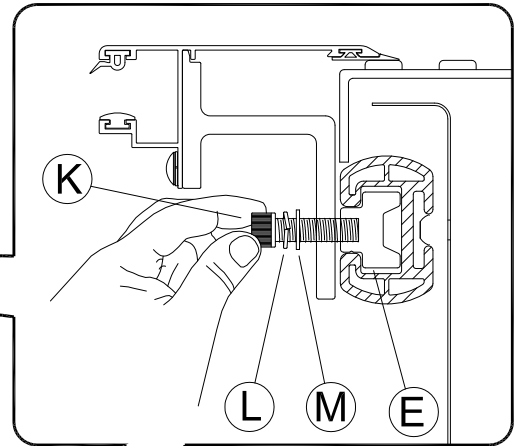

Loosely attach the track with the cap screw (K) and washers (L, M) to the threaded block (E).

9 LHS = RHS

Carefully close tailgate, shift the housing back so the end of the tracks are up against the tailgate.

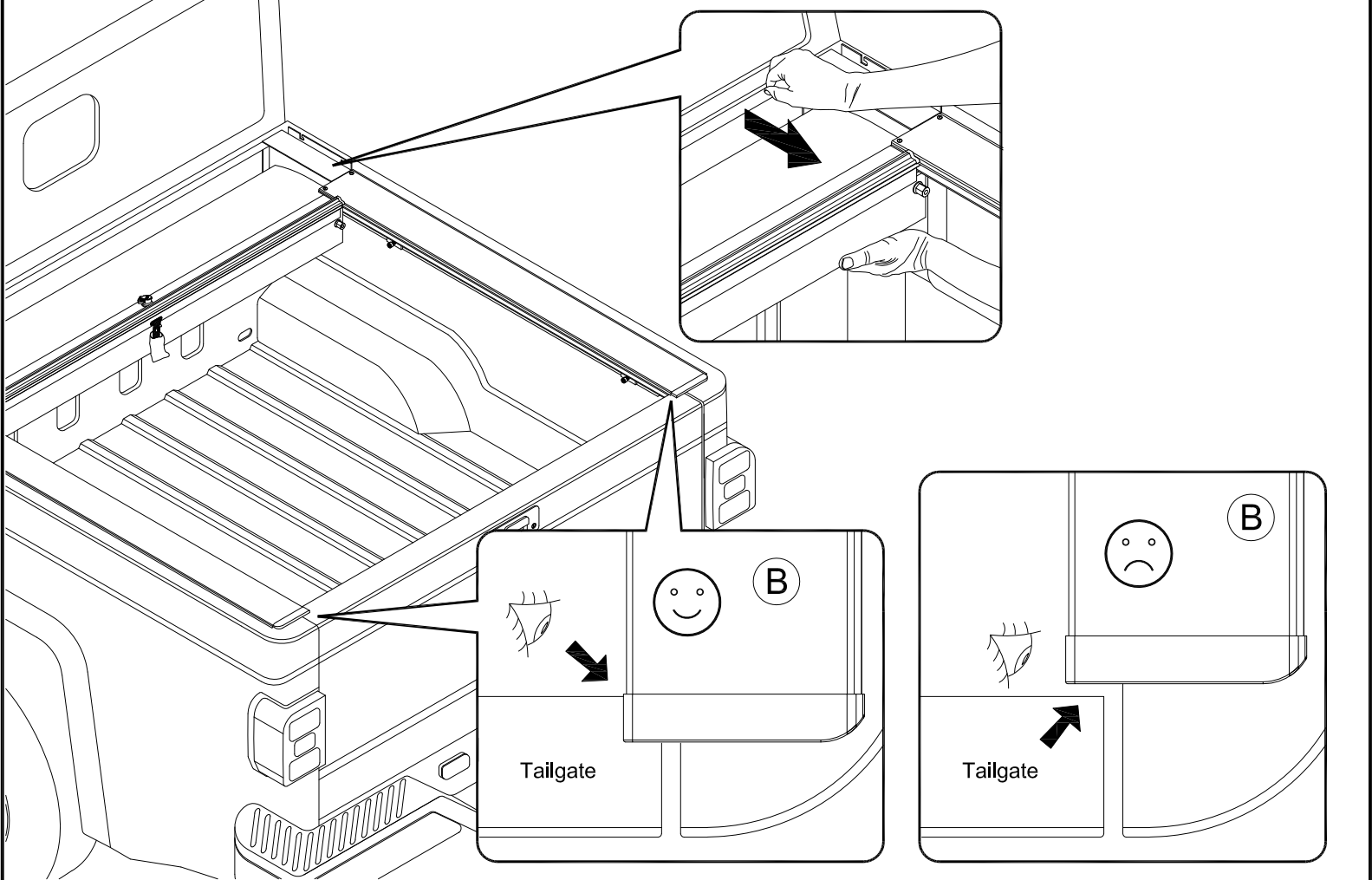

10

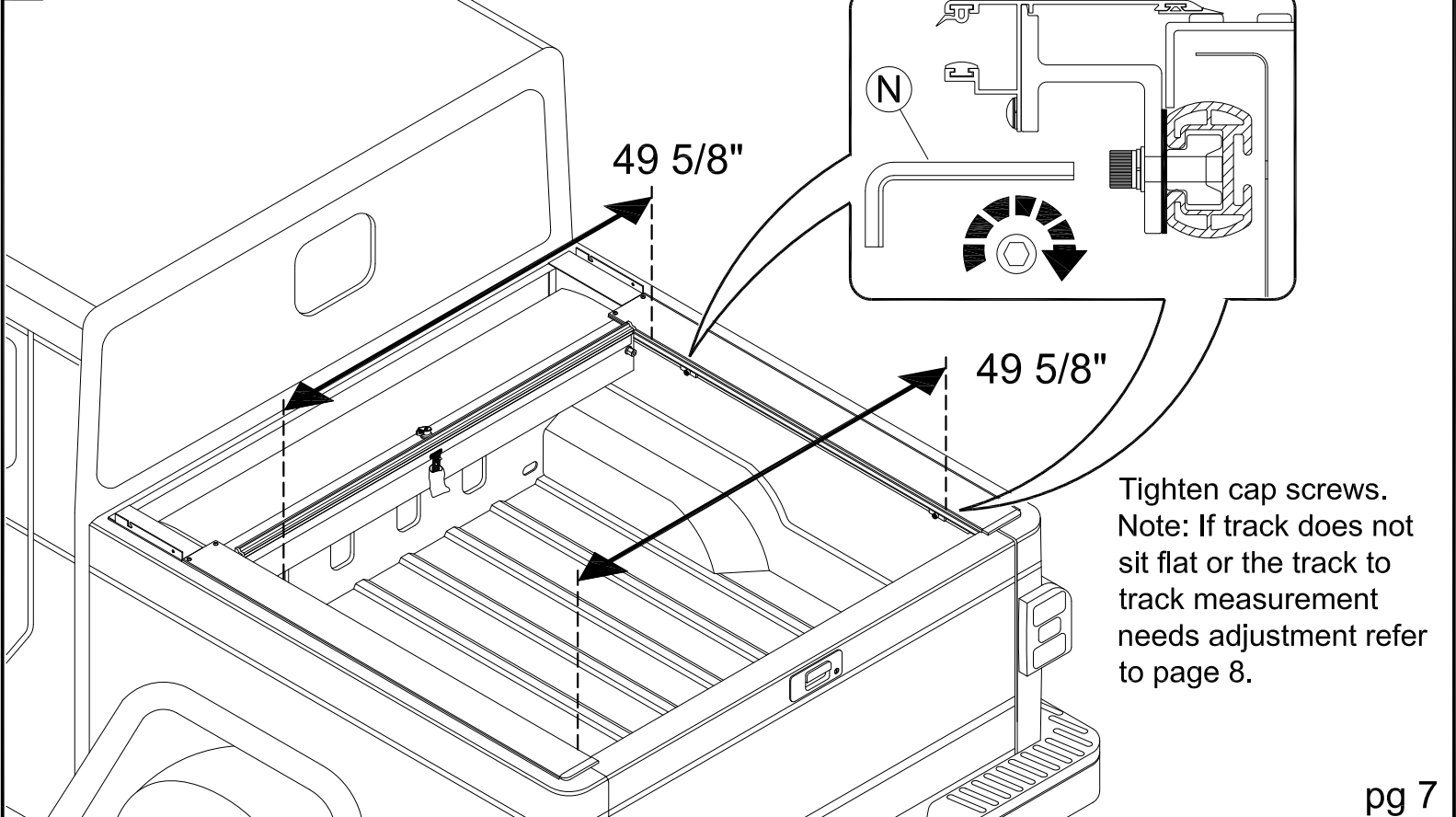

Tighten cap screws. Note: If track does not sit flat or the track to track measurement needs adjustment refer to page 8.

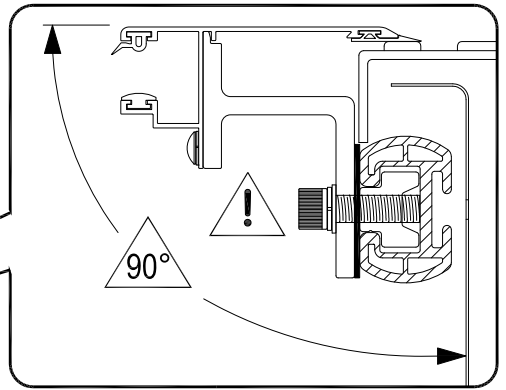
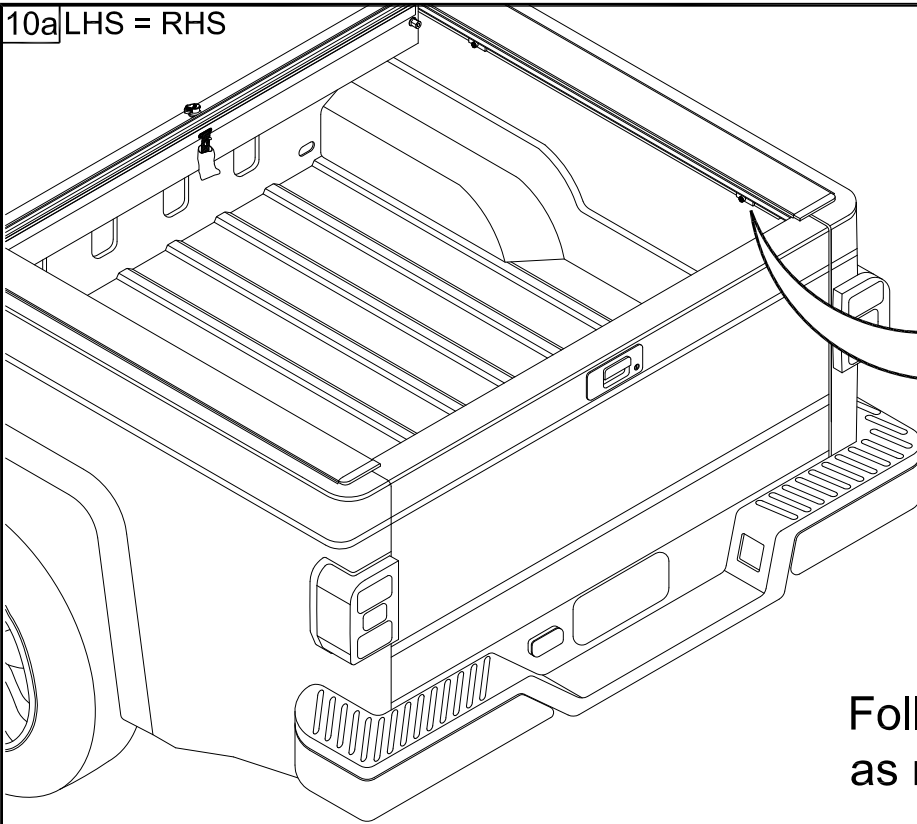

Follow the steps below as needed.

Track tips up or down.

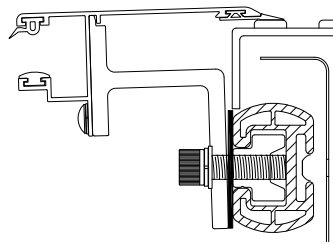

Insert leveling shim(s) (G) behind clamp(s) at tailgate as needed.

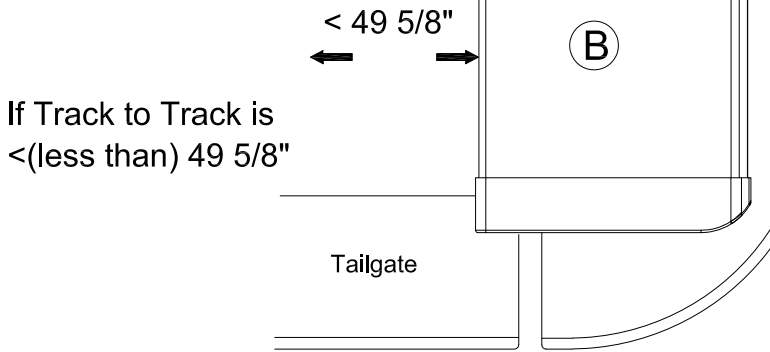
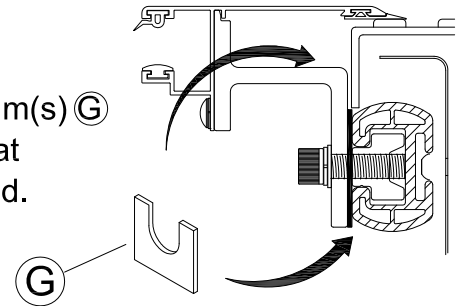

If Track to Track is <(less than) 49 5/8"

Remove existing shim(s). May need to replace with thinner supplied shim(s) (F).

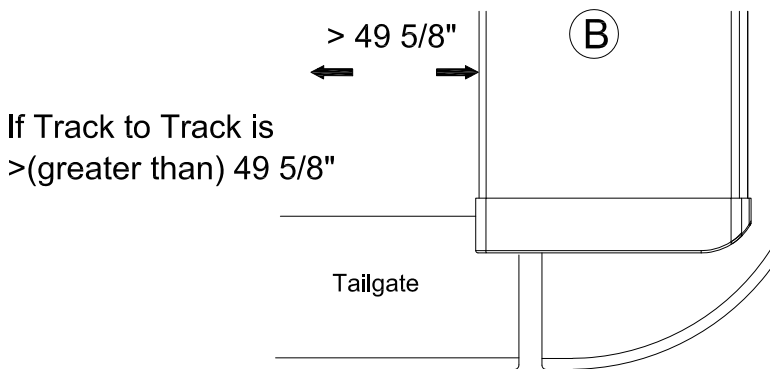
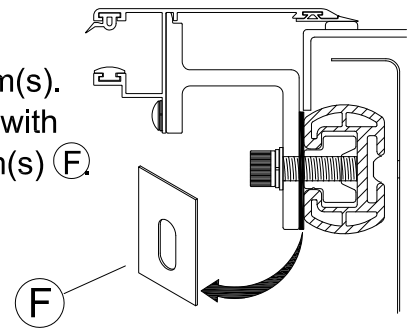

If Track to Track is >(greater than) 49 5/8"

Add width adjustment shim(s) (F) as needed.

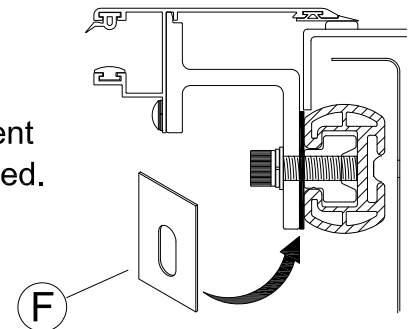

11

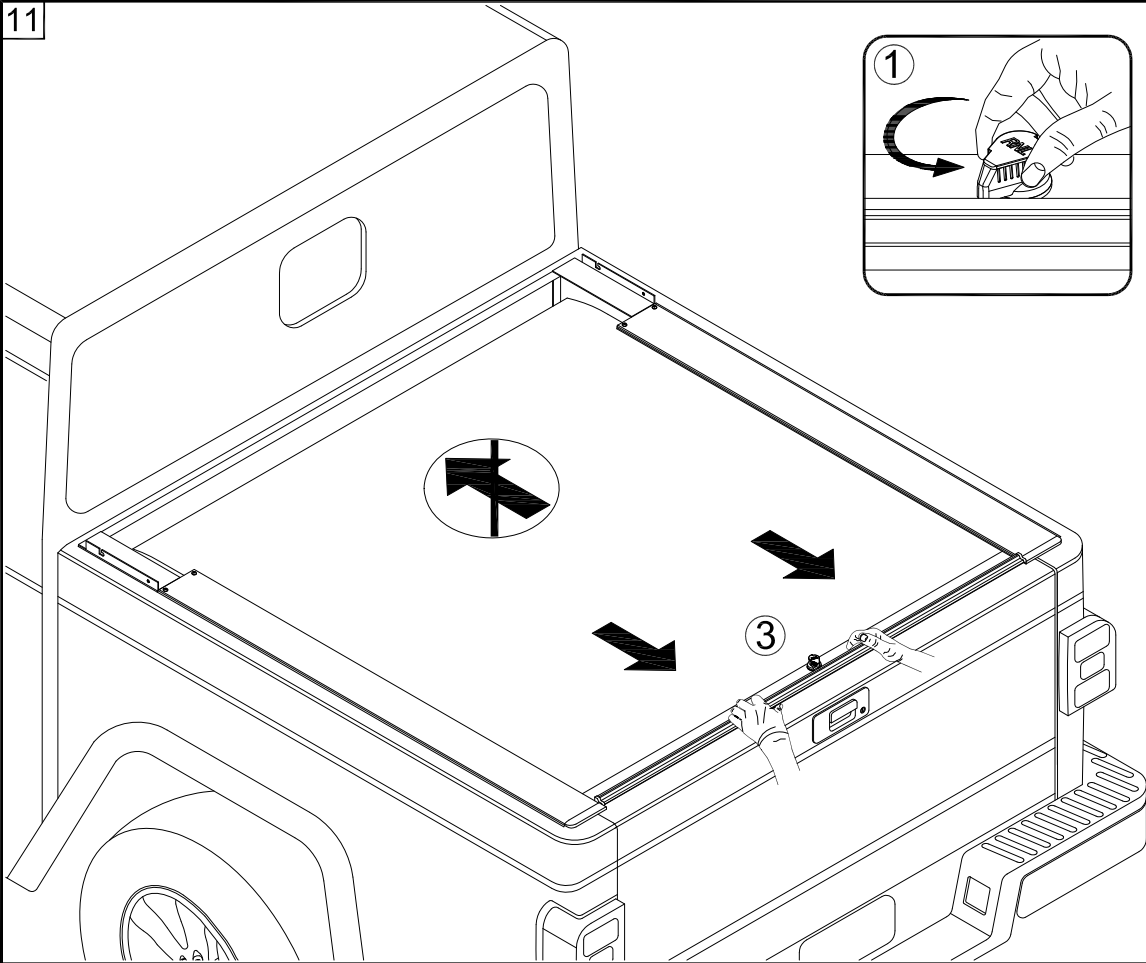

Turn lock to 7 o'clock, remove plastic wing nut and pull cover back to tailgate.

12 LHS = RHS

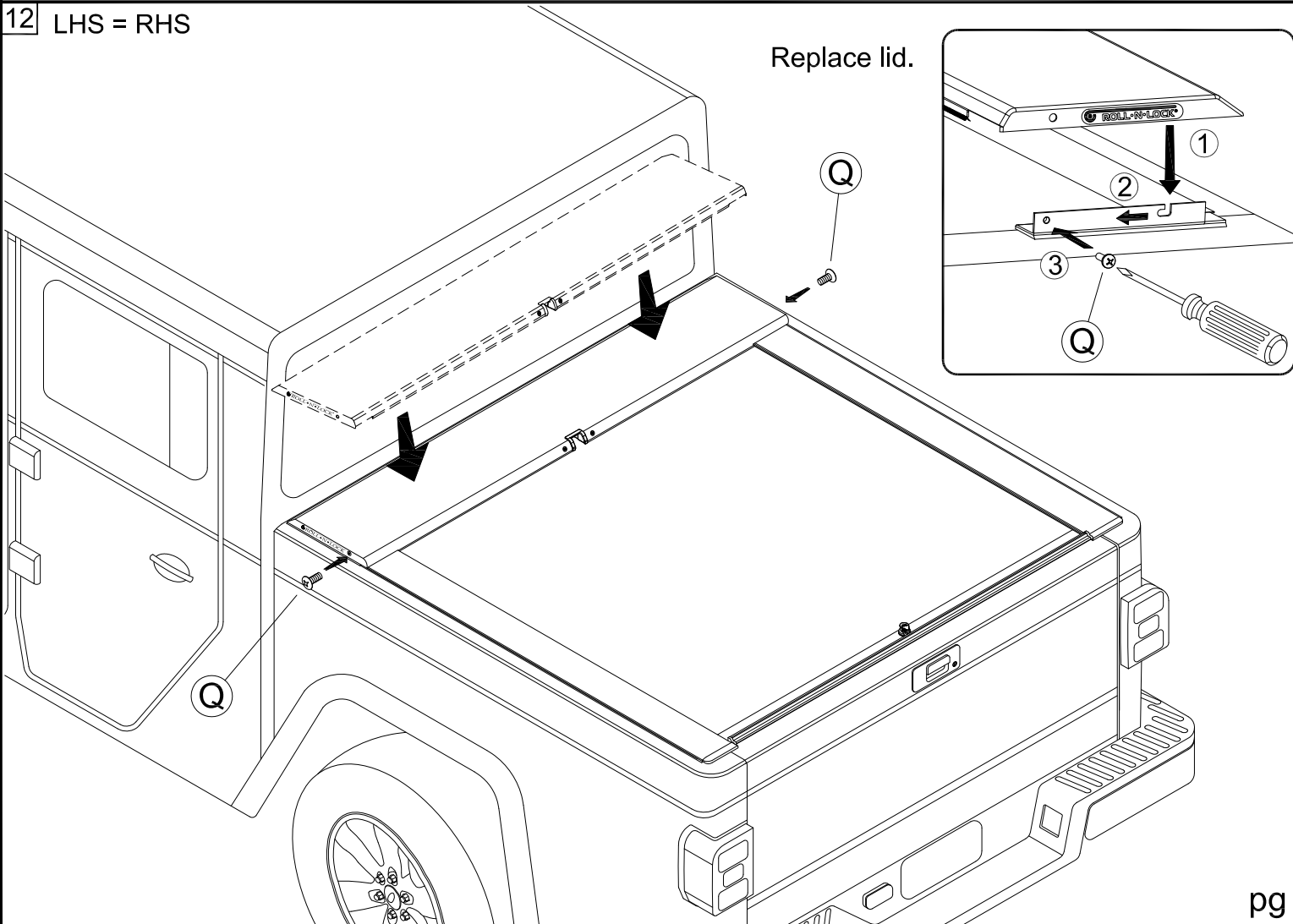

13

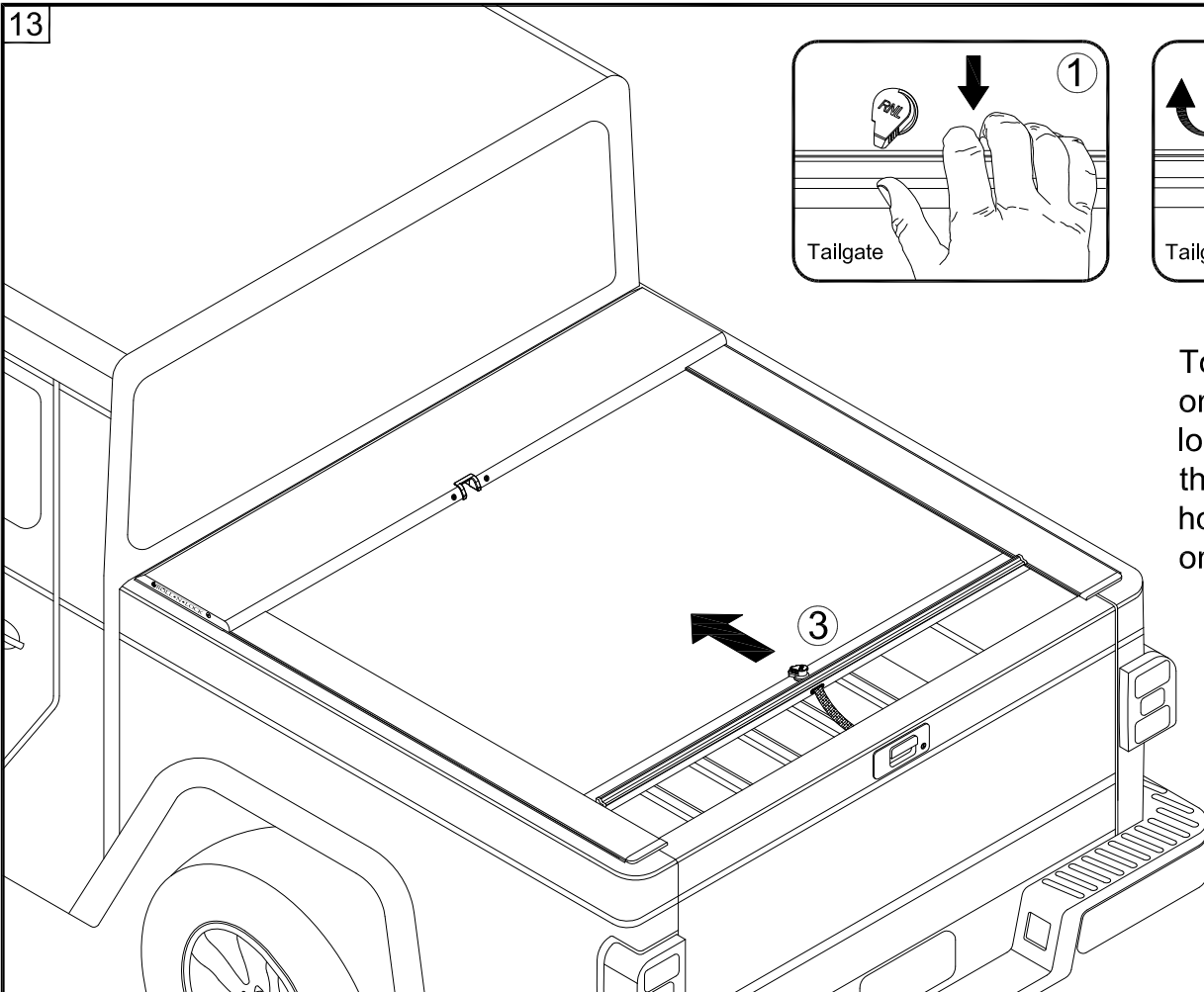
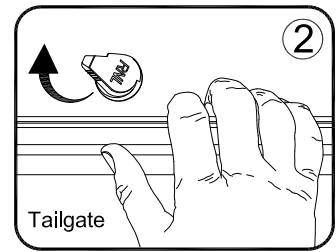
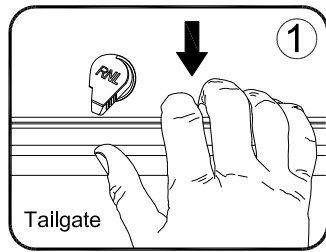

To open cover pull back on the handle, turn the lock to 10 o'clock and let the cover retract into the housing while holding onto the pull-strap.

14 LHS = RHS

Attach the Cargo Shield **C** to the housing. Note washer **P** placement.

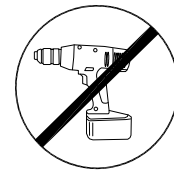
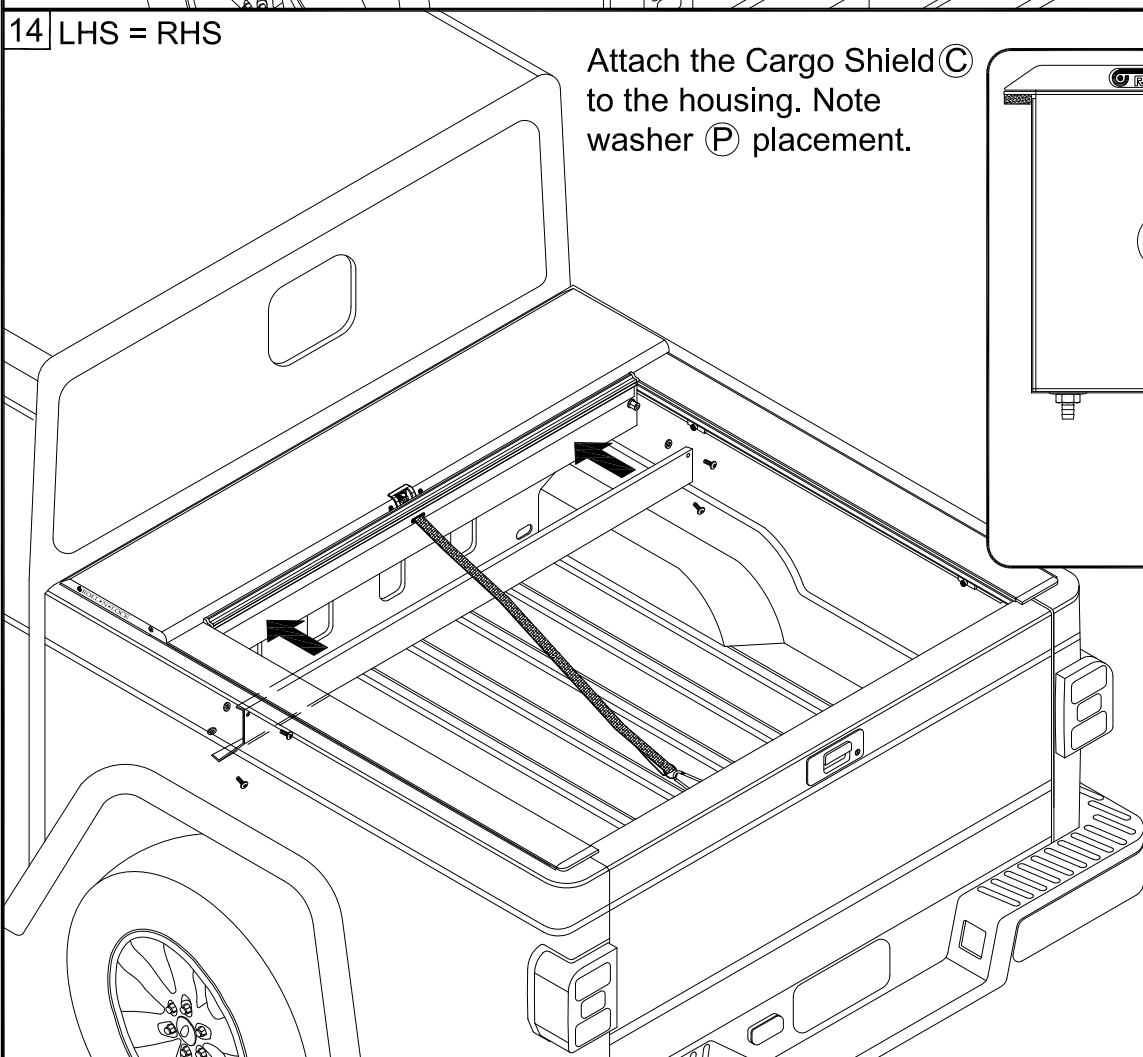
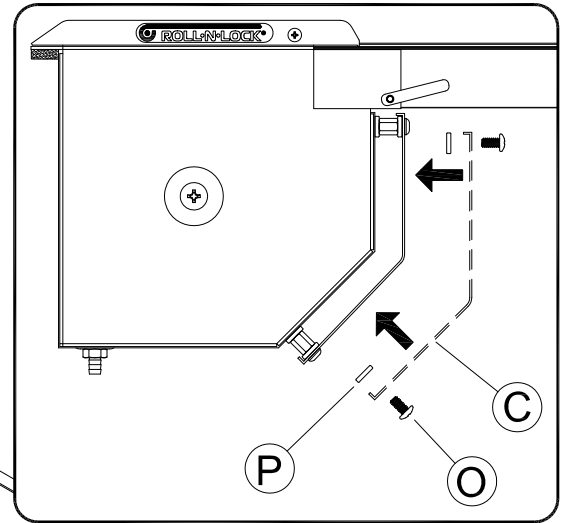

15 LHS = RHS

Drill 1/2" hole and insert one end of the Drain Tube® through and insert the other end onto the drain stem.

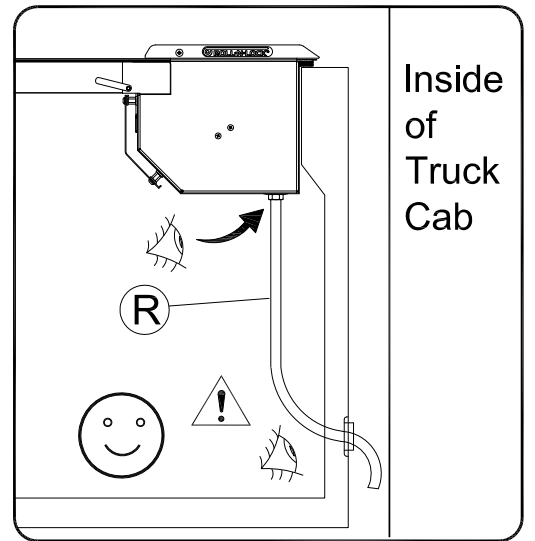
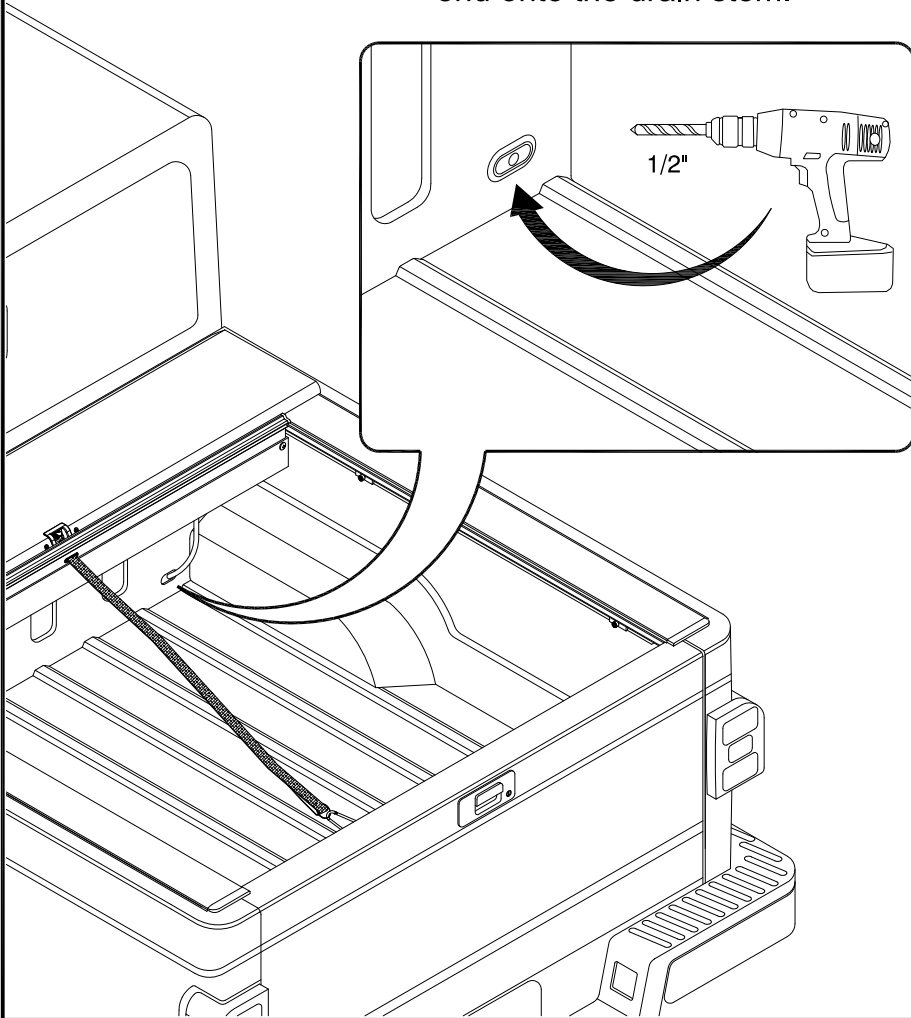

Inside of Truck Cab

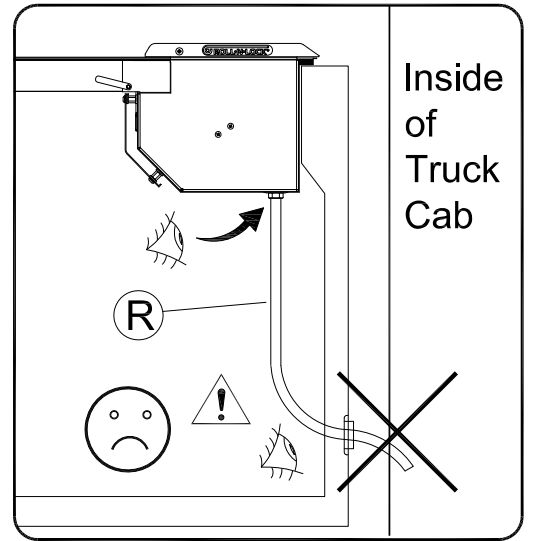

Inside of Truck Cab

16

Clip pull strap to truck.

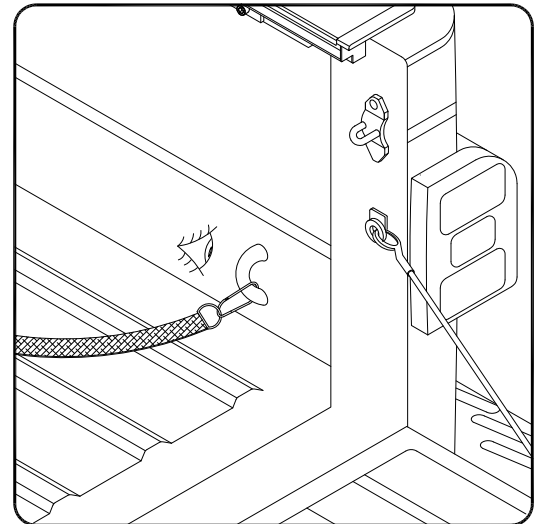
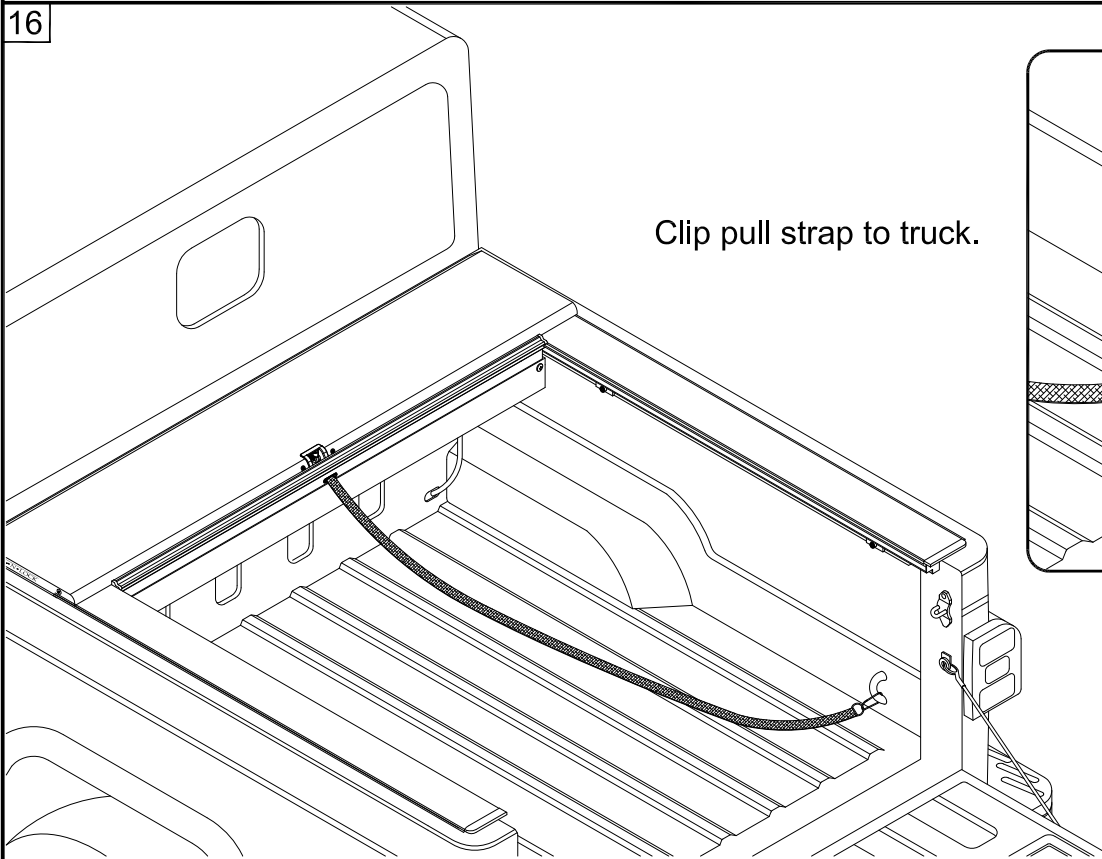

Troubleshooting

Cover is hard to pull or retract.



Spray 303[®] on a rag and wipe the top gasket in the Track back and forth.

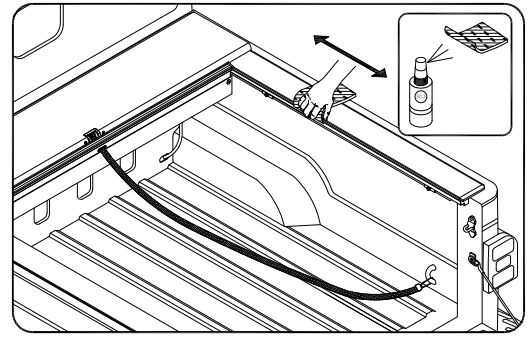

Cover does not latch.



Check track to track measurement.

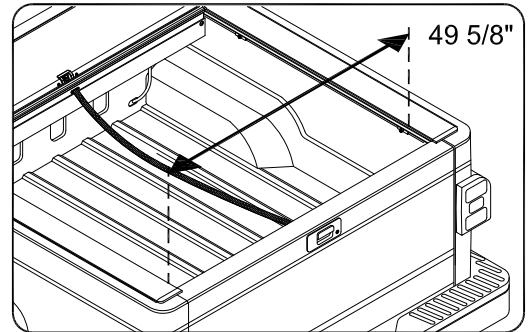

Cover does reach tailgate.



Make sure Tracks are back against tailgate.

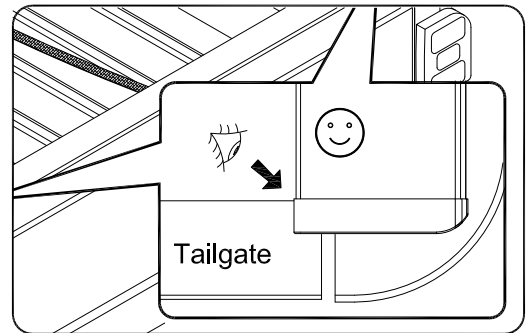

Track tips up or down.



Add shim as needed.

